

PETRO 3003 VOLUTANK (incl. SAFE+SPDS)

Operating Instructions

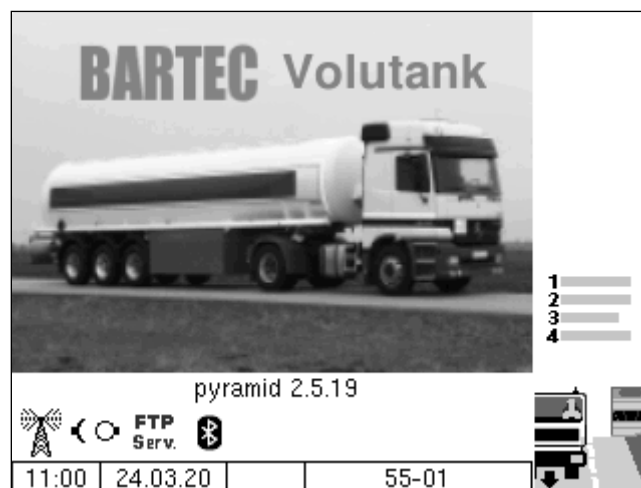

Software version pyramid 2.5.X

BA 151014

*All rights reserved. Subject to change without prior notice.
No part of this document may be reproduced, processed or distributed
in any form or by any means without the prior written permission of BARTEC.*

Copyright © 2020 by
BARTEC
Schulstraße 30
D-94239 Gotteszell

Table of Contents

Contents		Page
1	About this manual	4
2	Safety precautions	5
3	Basics	6
3.1	Operating unit (HMI)	7
3.1.1	Keypad	7
3.1.2	Display	7
3.2	Operating concept	8
3.2.1	The software user interface	8
3.2.2	Softkeys	8
3.2.3	Icons for data handling	11
3.2.4	Operation with trailer	11
3.2.5	Info line	12
3.2.6	Event display	12
3.2.7	Print screen	13
3.3	Operating the menus	14
3.3.1	Password protection	14
3.3.2	Opening a menu	15
3.3.3	Editing parameters	16
4	Operation the measuring system	20
4.1	Tour start	20
4.2	Loading	21
4.2.1	Loading menu	21
4.2.2	Filling compartments	22
4.2.3	Product assignment	23
4.2.4	Print load receipt	23
4.2.5	Empty test	24
4.2.6	Selecting company	25
4.2.7	Manual opening of bottom valves	26
4.2.8	Bypassing SAFE components	27
4.3	Product delivery	30
4.3.1	Delivery menu	30
4.3.2	Direct outlet delivery	31
4.3.3	Collector delivery	33
4.3.3.1	Simultaneous delivery from several compartments	33
4.3.3.2	Consecutive delivery from several compartments	36
4.3.3.3	Part delivery	40
4.3.4	Functions during the delivery process	41
4.3.4.1	Displaying delivery information	41
4.3.4.2	Preset quantity	42
4.3.4.3	Quality assurance system „SAFE 3003“	43
4.3.5	Delivery with optical overfill prevention (Switzerland)	45
4.3.6	Finishing orders	49
4.4	Valve monitoring	51

Contents	Page
4.5	Operation with data transfer from OBC _____ 52
4.5.1	Order data _____ 52
4.5.1.1	Receiving order data _____ 52
4.5.1.2	Order data display _____ 53
4.5.1.3	Show order items _____ 54
4.5.1.4	Hose selection _____ 54
4.5.2	Loading _____ 55
4.5.3	Direct outlet delivery _____ 56
4.5.4	Delivery via collector `wet hose parallel` _____ 58
4.5.5	Delivery via collector from the trailer `wet hose parallel` _____ 60
4.5.6	Pumping over from the trailer _____ 63
4.5.7	Flushing the wet hose _____ 65
5	Administration menu _____ 68
5.1	Entering the driver password _____ 68
5.2	Parameter Print Out _____ 70
5.3	Service Menu _____ 72
5.3.1	Long Term Storage (3 months storage) _____ 72
5.3.2	Logfile Browser _____ 73
6	Additional Functions Menu (within a tour) _____ 74
6.1	Journal Print _____ 74
6.1.1	Print Current Tour _____ 75
6.1.2	Print not printed Tours _____ 75
6.1.3	Selection Tour-Journals _____ 76
6.1.4	Journal with errors _____ 77
6.1.5	Show Bypasses _____ 80
6.1.6	Print Tourinfo _____ 81
6.2	Switch off System _____ 82
6.3	Long Term Storage (3 months storage) _____ 82
6.4	Print Document _____ 84
6.5	Password Input _____ 84
6.6	Load mapping _____ 85
6.7	Delivery Mapping _____ 86
6.8	Empty test _____ 87
6.9	Select Company _____ 88
6.10	Self Filling _____ 89
6.11	Drain Collector _____ 92
6.12	Flush Wet Hose _____ 93
6.13	Flush Wet Hose to Trailer _____ 96
6.14	Emergency Load _____ 100
6.15	Delivery from the trailer via the truck counter _____ 100
6.16	Emergency Unlocking Cabinet _____ 103
6.17	Print Compartment State _____ 104
6.18	Couple / Uncouple Trailer _____ 104
6.19	Transfer from Trailer _____ 105
7	System monitoring _____ 108
7.1	Display of malfunctions _____ 108
7.2	Attention monitoring _____ 111
7.3	Alarm trigger device _____ 112
7.4	Emergency delivery _____ 112
7.5	Cabinet door monitoring _____ 113
7.6	Diagnostics menu _____ 114

Exclusion of liability

BARTEC GmbH and its vicarious agents only assume liability in the case of deliberate acts or gross negligence. The extent of liability in such a case is limited to the value of the order placed with BARTEC GmbH.

BARTEC accepts no liability for any damage resulting from non-observance of the safety regulations or from non-compliance with the operating instructions or operating conditions. Secondary damage is excluded from the liability.

EU-Declaration of conformity

We, BARTEC GmbH, Schulstraße 30, D-94239 Gotteszell, hereby declare, that this product is in compliance with the essential requirements of the relevant EU-directives.

The EU-Declaration of conformity for this product can be obtained from BARTEC GmbH, Schulstraße 30, D-94239 Gotteszell, info@bartec.com.

1 About this manual

The operating instructions are part of the product and must be kept in the immediate vicinity of the measuring system. The personnel for assembly, operation and maintenance must have access to it at all times.

Following the instructions in this manual is important for correct functioning of the measuring system during operation.

The illustrations in this manual are intended to illustrate the information and descriptions. They cannot always be transferred unchanged and may differ slightly from the actual design of the device.

BARTEC GmbH reserves the right to make technical changes at any time. BARTEC GmbH is under no circumstances responsible or liable for any indirect or consequential damages resulting from the use, operation or application of this manual.

Please read the Operating Instructions carefully before using the product.

This document must be kept by the user for the entire life of the product.

Signs and symbols

The following characters and symbols are used in this manual to highlight passages that need special attention.



Notes

This arrow indicates special features to be observed during operation.



Warning

This symbol draws your attention to passages that, if not followed or followed inaccurately, may result in damage to or destruction of parts of the system or loss of data.



Danger!

This symbol marks passages that, if not followed, endanger the health or life of humans.



License requirement!

This symbol indicates menus or individual parameters that are only available if a corresponding option requiring a license has been activated.

General information within the text is marked with a frame.

2 Safety precautions

The operator of the system is responsible for observing all the regulations in force for the storage, transportation and loading/unloading of combustible liquids.

Regulations and provisions lose none of their validity when the system is operated with PETRO 3003 units.

PETRO 3003 units are built with due consideration to the regulations currently in force and left the factory in perfect condition. Their installation and maintenance are to be entrusted to properly trained specialists only.

- Make sure that the data and operating conditions specified by BARTEC are observed.
- Follow the instructions for operating and servicing the units.
- If you discover any signs of damage or breakage on any parts of the system or if the system's safe operation cannot be guaranteed for any other reason, do not start the system or, if already in operation, shut down the system immediately.
Notify your maintenance department.
- Get in touch with our service specialists if you discover any faults or defects during operation or if you have cause to doubt that the units are working properly.
- PETRO 3003 units are not a replacement for a tanker vehicle's safety equipment or for a user's own safety measures (e.g. overfill protection).

To comply with water legislation provisions of the Water Resources Act (WHG) and the compliance of the Immission Control (20. BImSchV) in Germany, the system VOLUTANK 3003 offers the following security devices when configured according to the VdTÜV certificate TÜ.AGG and the VdTÜV information sheet:

- Overfill prevention system (AS) to prevent overfilling
- Filling hose protection (ASS) for preventing leakage of fluids
- Vapor return system (GP) for monitoring the gas recirculation
- Death man key and emergency stop function (ANA)

The measuring system may only be operated for applications that are subject to legal metrological control in the respective EU member state if the nominal operating conditions specified in the EU type examination certificate are met.

3 Basics

The PETRO 3003 system can be used to monitor, record and control all operations and operating processes for loading and unloading petroleum vehicles. The system is extremely flexible and can be adapted to meet different requirements using the variable range of hardware components.



Software options

For the software from version *pyramid 2.5.X*, various options are only available after purchasing a corresponding license.

When updating from an older software version without options which require a license, all options used up to that point remain active.

Basic options

- „VOLUTANK 3003“: Electronic dipsticks are used in the measuring system to record the quantities when the products are loaded or delivered.
- „SAFE 3003“: The quality assurance system prevents products from being mixed during loading or delivery (section 4.2.8, 4.3.4.3, 6.6 and 6.7).
- „SPDS 3003“: The Sealed Parcel Delivery System is used to seal loads electronically on petroleum vehicles. This ensures that the product arrives at the customer's premises in the same quantity and quality that was present during loading (section 4.4).

Further options for the operation of the measuring system, which can be combined with the basic functions

Wet hose delivery 3003	Dipstick volume measurement with wet hose delivery
TIGER Ex	Measuring system TIGER Ex, Turbine measuring system. <i>(The system is operated like the delivery described via the collector.)</i>
Fuel tanker Combo	Dipstick rigid & trailer with automatic control, pumped delivery from the trailer over the rigid. A separate quick guide is provided for this.
GPRS/UMTS-online function	Office connection, reading out data and data specification TVE1 (see section 4.5)
GPS petrol station database	Automatic localization of the petrol stations via GPS and display of the associated customer data.
Shift matrix	Company-specific requirement for the deliveries / bypasses (see section 4.2.6 and 6.9)
Simultan delivery G+P	Simultaneous delivery via direct outflow and collector delivery
Product selection delivery	Product selection for collector delivery with additive pump (see section 6.7)
TVE1 – TVE2 communication	TVE1 TVE2 shared printer, office connection TVE2.
SPD minitrailer	Single compartment trailer, only possible in connection with rigid with option SPDS 3003, no quantity measurement.
SPDS 3003 Stand alone	Electronic sealing of the cargo, Valve monitoring with recording; no quantity measurement.
SAFE 3003 Stand alone	Quality assurance system to prevent product mixing during loading and delivering; no quantity measurement.

The content of the displays depends on the software options installed, their configuration and the hardware components used. Depending on this, the display images shown in this document may differ from those on your system.



How to start up the system and to operate the vehicle equipment depends on the vehicle type and the therefore valid operating instructions.

3.1 Operating unit (HMI)

The operating unit (HMI) acts as the central control and information unit for the entire system. Communication between the operating unit and other components within the system takes place via USB or, in the case of P-NET devices, via P-NET.

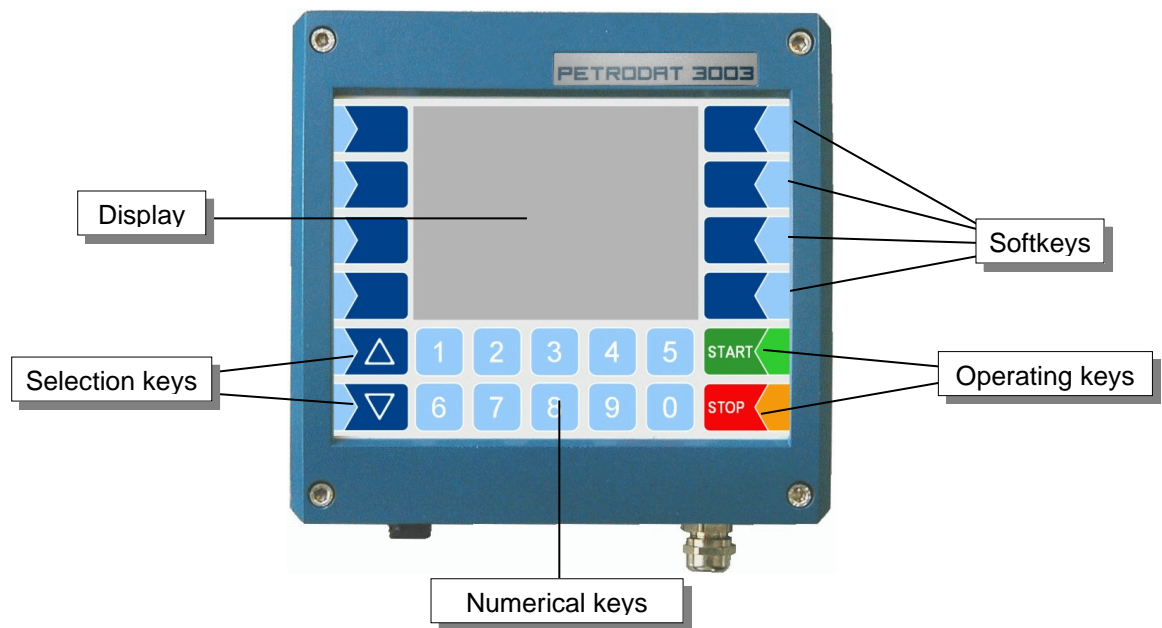

3.1.1 Keypad

The system can be operated using the touch-sensitive keys on the operating unit (touch screen with numerical keys, selection keys, softkeys and operating keys) as well as key functions that are shown on the display depending on the situation. The functions of the softkeys are controlled by the software according to the current operating status.

3.1.2 Display

A graphical screen designed as a touch screen is used to display all information. In addition to the touch-sensitive keyboard, various functions can also be operated directly using controls on the display surface.

3.2 Operating concept

3.2.1 The software user interface

The controller software is constantly evolving. A different software version or configuration may cause the screen displays on your system to differ slightly from the illustrations in this document.

When the system is started up, the main menu appears on the display. You can access the various displays or operating modes using the softkeys to the left and right of the display.

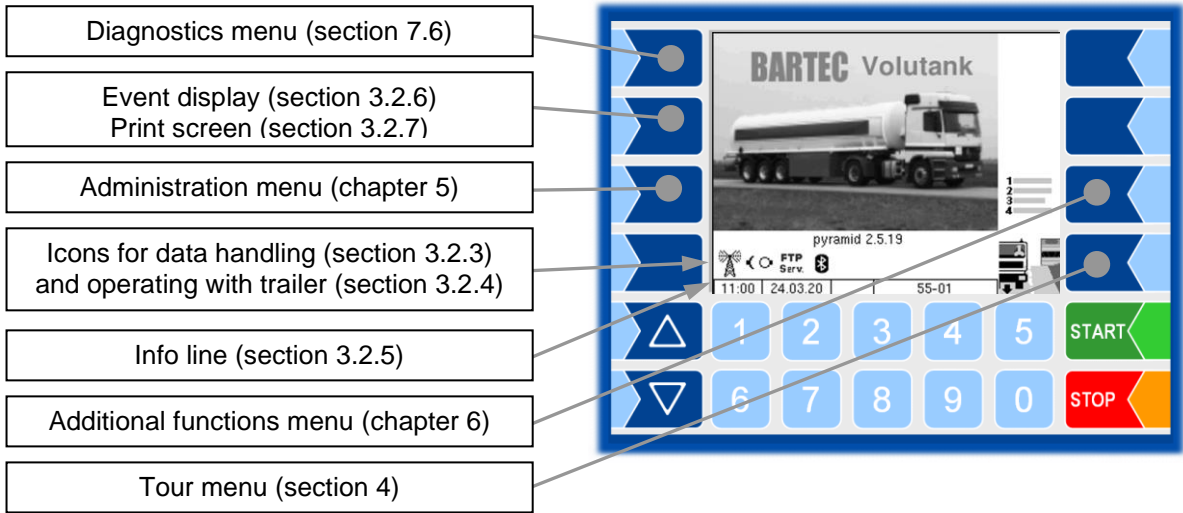







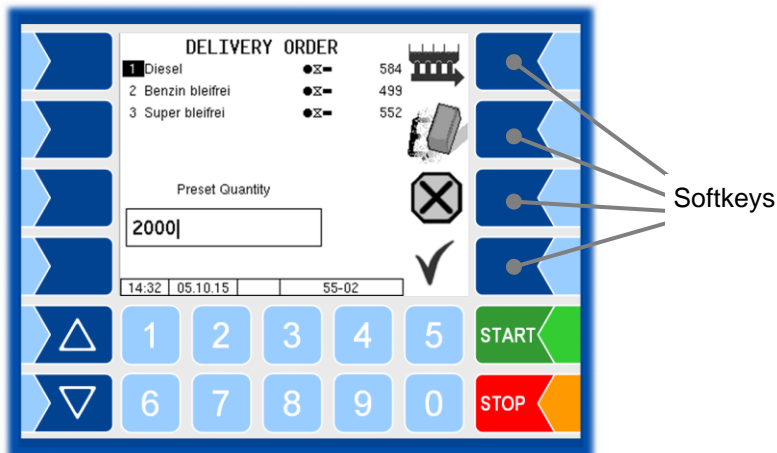



























3.2.2 Softkeys

The softkeys can be assigned various functions, the current meaning of which is indicated by symbols.

All keys are touch-sensitive, meaning that you don't need to press them but simply have to touch them.











Symbol	Meaning	Effect
	Confirm	A selected menu is opened. A selected parameter setting is confirmed.
	Close menu	The menu that is currently open is closed and the system switches to the next menu up in the hierarchy.
	Cancel	The menu that is currently open is closed and the system switches to the next menu up in the hierarchy. Any settings or entries that have been made are discarded.
	Edit	An entry or selection dialog is opened for the selected parameter.
	Correct	The character to the left of the cursor in an entry dialog is deleted.
	Accept, save	The menu that is currently open is closed. All settings/entries that have been made (including those in lower level menus) are accepted and saved. All changes are only saved if you exit the menu or entry dialog using this softkey!
	Additional functions menu	The Additional Functions menu is opened.
	Start tour	A tour is started (load/deliver product).
	Load	The Loading menu is opened.
	Delivery	The Delivery menu is opened.
	Emergency delivery	If a hardware fault would normally prevent delivery, the faulty hardware can be bypassed.
	Simultaneous collector delivery	If delivery via a collector is selected, the delivery takes place from all selected compartments simultaneously.
	Sequential collector delivery	If delivery via a collector is selected, the delivery takes place from the selected compartments sequentially in a selectable order.
	Bypass	SAFE components are bypassed.
	Pre-set quantity	The dialog for entering a pre-set quantity is opened.
	Change page	If the displayed information extends over more than one page, you turn to the next page.
	Start delivery	The delivery process is started from the selected compartment.

Symbol	Meaning	Effect	
	Removal of residues	Residues are automatically removed from the collector at the end of the dispensing or after rinsing.	
	No removal of residues	Automatic residue removal at the end of dispensing or after rinsing is deactivated, the collector remains filled when the specified amount is reached.	
	Save	finish delivery / save delivery data	
	Finish collector delivery	finish collector delivery / save delivery data	
	End order, print	The current delivery order is ended and the delivery note or invoice is printed.	
	Password input	The window for entering the password is opened (Driver-, User- or Service-Password).	
	Change User password	The User password (configuration level 2) can be changed.	
	Start download	The software download from the BARTEC server is started (Service menu).	
	Cancel download	The software download from the BARTEC server is cancelled (Service menu).	
	Send/receive	Communication is started manually with the message box (service function for configuring office communications).	
	Send/receive	Communication is started manually with the message box (service function for configuring office communications).	
	Print preview	Displays a preview of the document to be print.	
	Print	Prints the selected or displayed data.	
	Edit product assignment	After entering the service code, you can assign the products from all products which are configured during load mapping.	
	Show Information	Information about missing SAFE components will be displayed.	
	Request to the BARTEC server	A license request is sent to the BARTEC server.	
	Disconnect mini trailer	Disconnects the logical connection to the mini trailer.	With activated software option <i>SPD mini trailer</i> .
	Connect mini trailer	Establishes the logical connection to the mini trailer.	





3.2.3 Icons for data handling

The following icons are used to monitor the data handling and will appear in the display above the info line.

Symbol	Meaning
	Response data is provided for transmitting
	Modem is switched on
	Modem is switched on, connection has been established
	Receiving data
	Sending data
FTP Serv.	Online Service connection via FTP server is active
	Bluetooth interface is active
	Bluetooth connection established
	Scheduled data available
	Scheduled data processed

3.2.4 Operation with trailer

If the vehicle is configured to operate with a trailer, in addition to the Icons for data handling , the following symbols can be displayed.

Symbol	Meaning
	Trailer docked
	Communication with trailer available
	Communication with trailer interrupted
	Trailer undocked
	Delivery from the trailer



When attaching or detaching the trailer, you must log it on or off in the Additional Functions Menu (see section 6.18).

3.2.5 Info line

The info line shows the date and time, information about the operating status and the software page number.

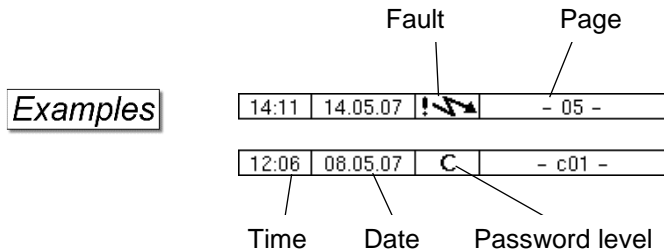

3.2.6 Event display

Important error or fault messages are displayed directly on the display. The second softkey left of the display is used to open the event display, which shows all operating statuses and faults (touch briefly).

You use the softkey ✓ to acknowledge messages that are displayed. The “Event display” is automatically closed after 20 seconds. Error messages are not deleted until the cause of the error has been removed. The fault symbol is displayed in the info line during this time.

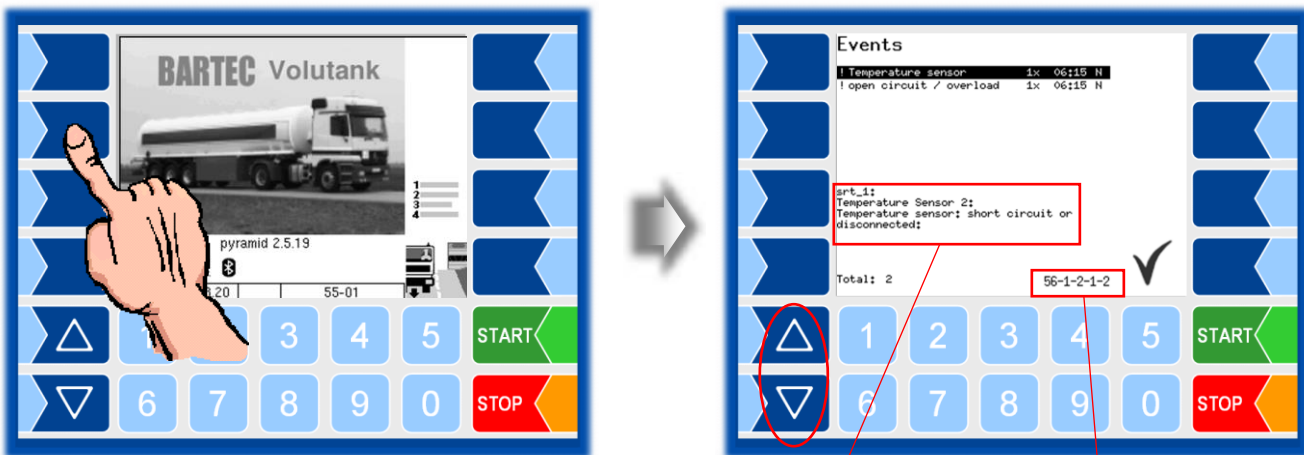

Information about the selected error Error code of the selected error

Maybe in the event display more than one error are displayed. Use the arrow-keys to select the individual messages. For the currently selected error, more information and an error code are displayed (see also section 7.1, page 109).

3.2.7 Print screen

When you touch the second softkey from the top left of the display at least for two seconds, the current screen will be printed.

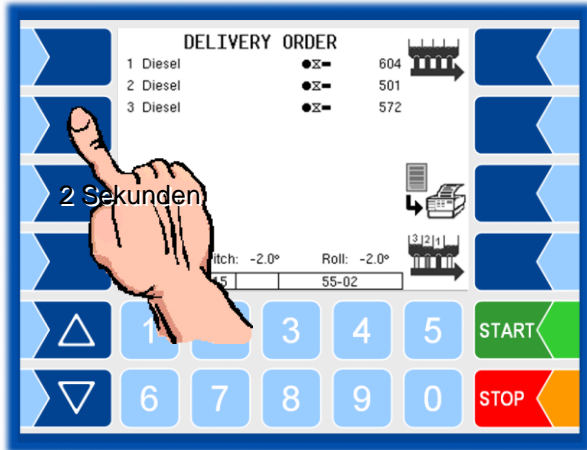

3.3 Operating the menus

3.3.1 Password protection

Various menu functions are only available after entering a password. The access options depend on the password level to which the password applies. The mark of the password level currently accessible is indicated by a letter in the info line of the display. Each password level includes all lower password levels.

Password level	Mark	Access
0: No password		Read only
1: Driver password	D	Time, language, driver number
2: User password	U	Operating parameters
3: Service password	S	Software parameters not subject to statutory calibration
4: Open seal switch	C	All parameters

No password

- Operation of the system
- Open configuration menus, but no changes can be made.

Driver password

- Setting the time (System Parameter/System Time)
- Setting the language (System Parameter/Language)
- Configuration of the driver number (Program Parameter/Driver Id.)
- Entering the driver password is described in section 5.1.

User password

Fleet manager password.

- Editing of configuration data that are not subject to calibration and that are not protected by the service password.

Service password

- Editing of all configuration data that are not subject to statutory calibration.

Seal switch

- Access to all parameters, including those subject to statutory calibration.



Whenever the seal switch is opened, re-calibration by an official office, for which a charge will be made, is compulsory!

3.3.2 Opening a menu

1. Touch the corresponding softkey to open the desired menu.

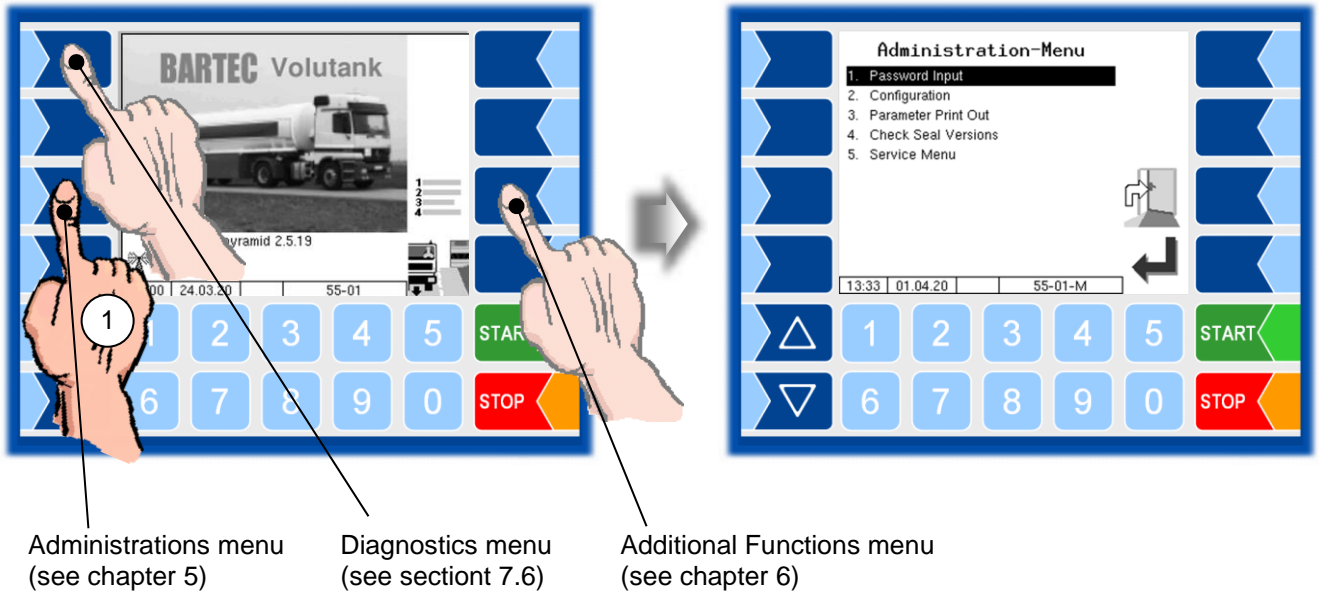

2. Use the selection keys ∇ and \triangle to select the menu you wish to open. The selected menu is highlighted with a black bar.
3. Touch the "Confirm" softkey to open the menu.



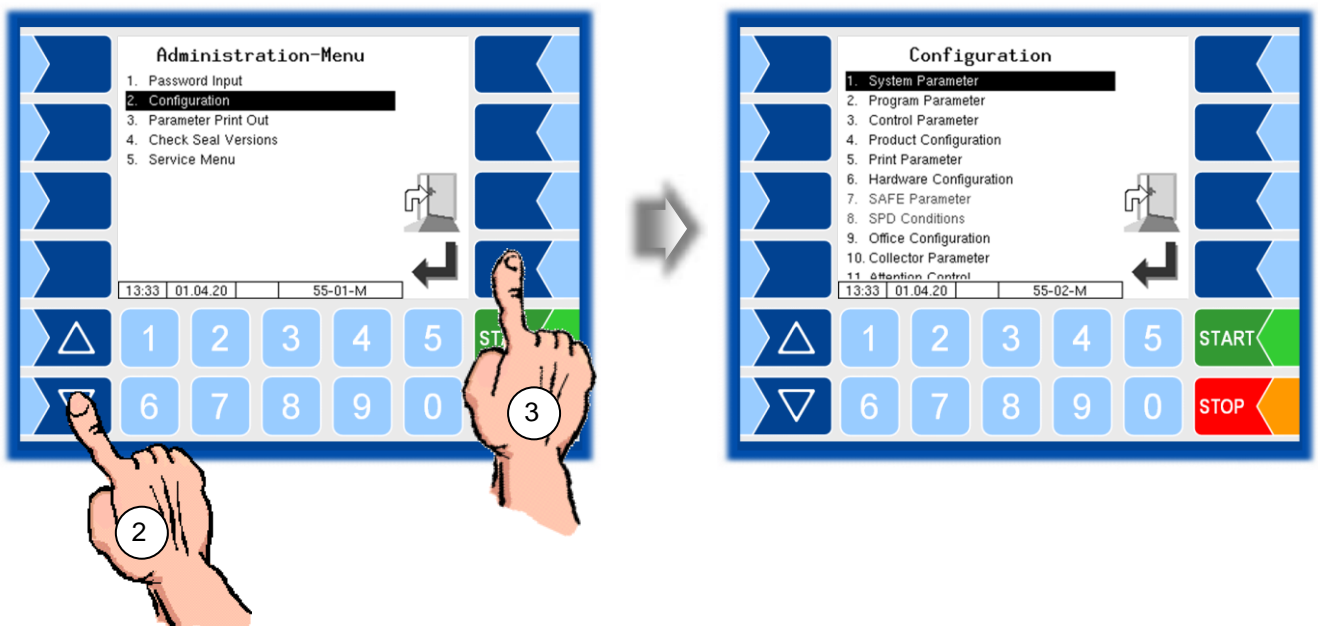

You can also open the desired menu directly using the corresponding numerical key.



If the menu contains further submenus, you can open the required submenu in the same way.

3.3.3 Editing parameters

1. Use the selection keys  and  to select the parameters you wish to edit. The selected parameter is highlighted with a black bar.
2. Touch the "Edit" softkey to open the edit window (entry or selection dialog).



The "Edit" softkey is only available if you are authorised to edit the selected parameter in the current password-protected configuration level (see section 3.3.1).

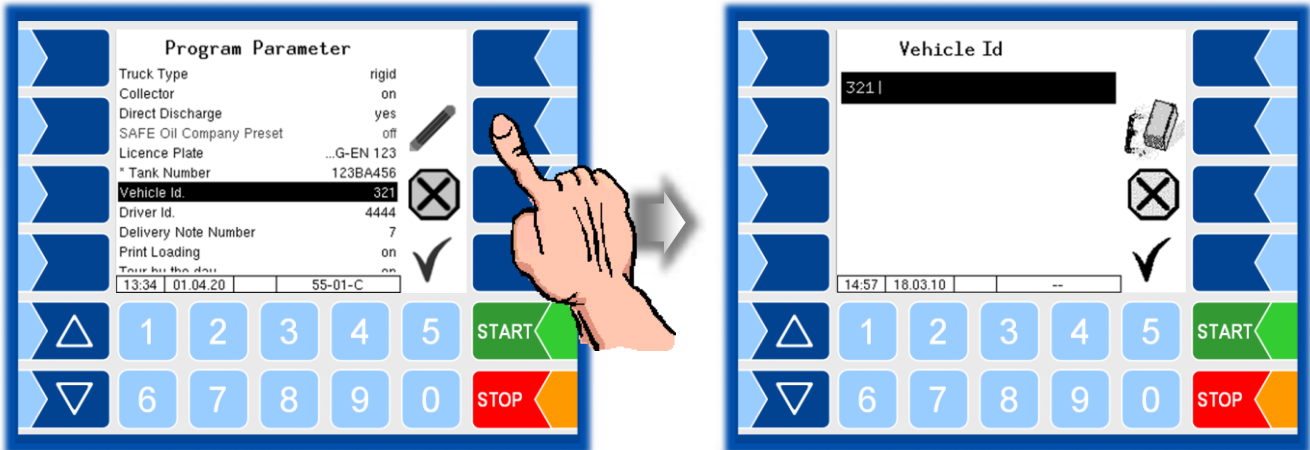

If not all entries in menus or lists can be displayed in the screen, you can use the selection keys to scroll lines or pages.

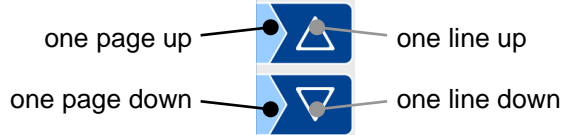

Numerical entries

Numerical entries are entered using the keys below the display.

If you need to make any corrections, you can use the softkey with the rubber symbol. When you touch this softkey, the character to the left of the cursor is deleted.

If a parameter must be entered with a positive or negative value, you can use the sign softkey \pm .

Confirm your entry using the "Confirm" softkey".

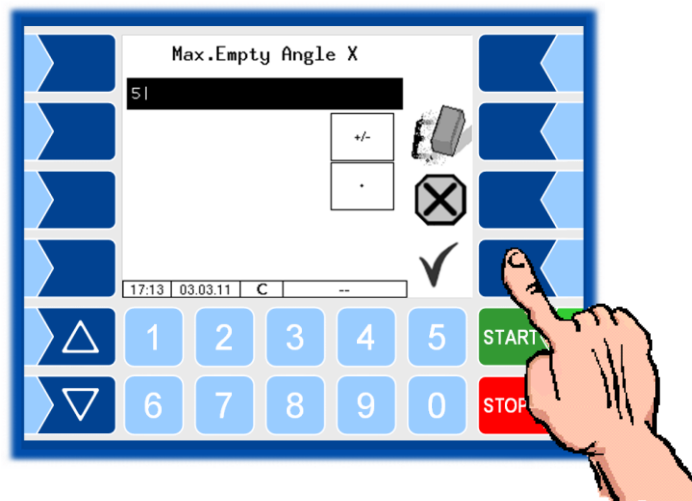

Alphanumerical entries

Letters are entered using the keys that are shown on the display. To enter a letter, simply touch the corresponding key. The keys are assigned up to four characters. You determine which character appears in the input line by pressing the key the appropriate number of times in quick succession.

You can enter a blank with the \square key.

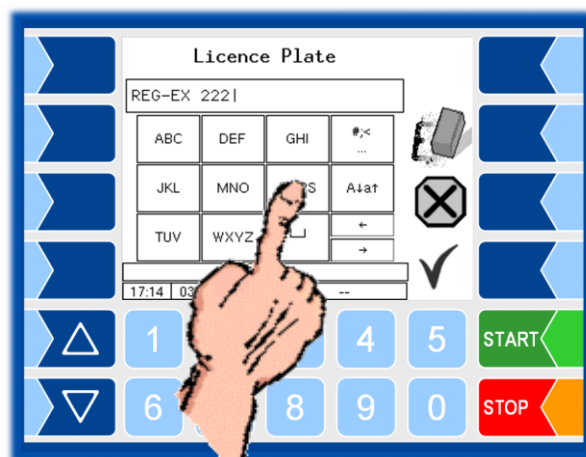

Shift key

You can use the A|a key to switch from upper case to lower case letters and vice versa.

Special characters

If special characters need to be entered, you can use the **#;<** key to switch the key assignment to the special character level. You can switch back to letters using the same key, which is now labelled **abcā**.

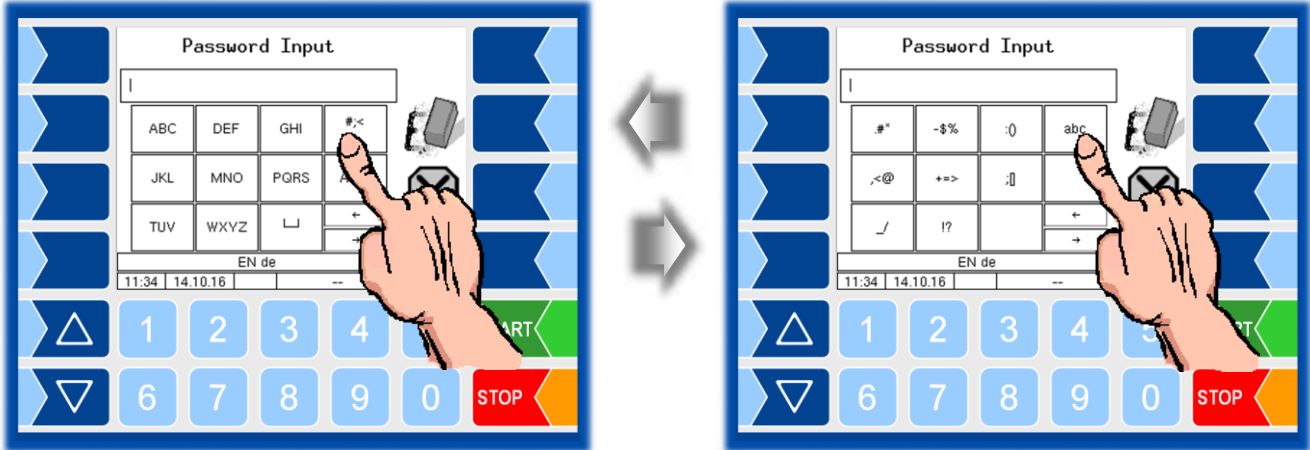

Once you have finished making your entry, touch the “Confirm” softkey“.

Selection lists

Selection lists are available for certain parameter settings. Select the required setting using the selection keys **▽** and **△**. The selected setting is highlighted with a black bar. Confirm your selection using the “Confirm” softkey.



You can also select the desired setting directly using the corresponding numerical key.

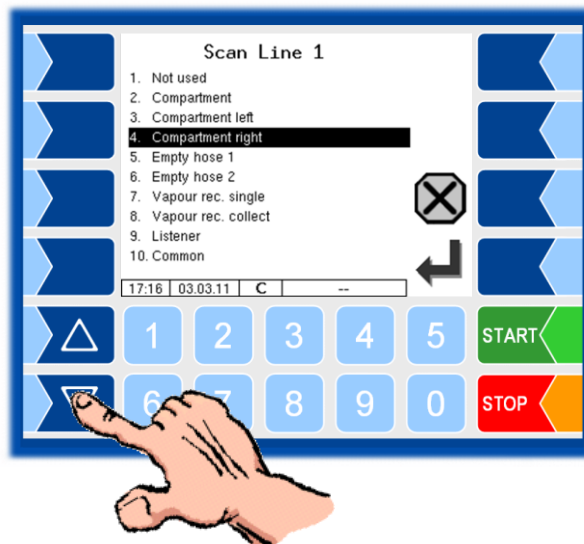

Alternatives

In the case of parameters for which only two alternative settings are possible, e.g. yes/no or on/off, the settings are switched when you touch the “Edit” soft-key or a numerical key.

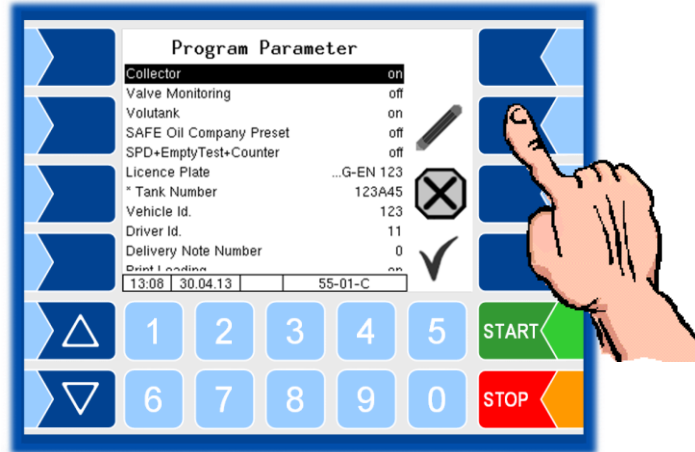

After changing the selected parameter, the next line is automatically highlighted.

4 Operation the measuring system

4.1 Tour start

In order to load and deliver products, you need to start a tour.

- Touch the "Tour Start" softkey.
Information about the available compartments are displayed. If the vehicle is equipped with an external angle measuring system, the longitudinal and transverse inclination angle of the vehicle are also displayed.

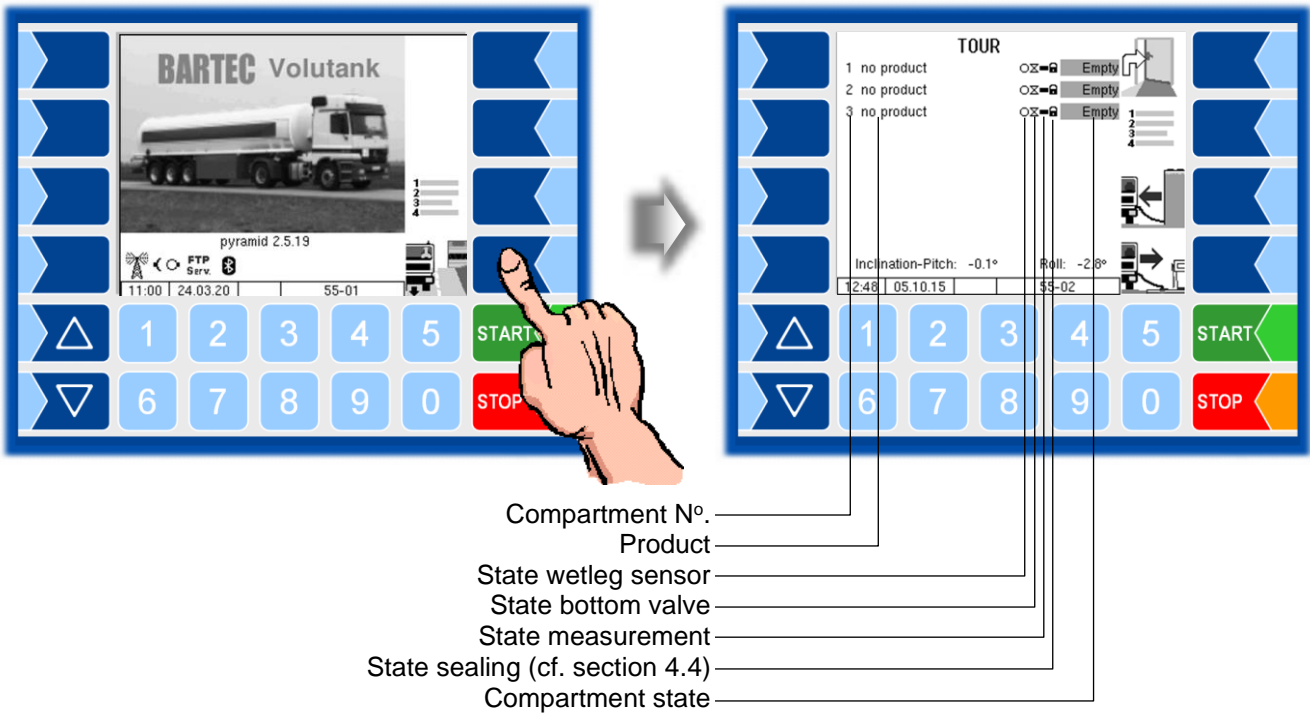

Status indication on the display

Wetleg sensor		Bottom valve		Measurement display		Compartment status	
○	not wet	⊗	closed	—	stable	Empty	Empty *
●	wet	⊞	open	~	not stable	Rest	Residual * Filling level in not measurable range, Residual sensor not wetted (Emptying time not expired).
✕	Error			↑	increasing		
				↓	decreasing		
				✕	Error		
State sealing						60	max. residual quantity Filling level in not measurable range Residual sensor wetted.
🔒	Compartment sealed					2400	currently measured level
🔓	Compartment not sealed						

* The compartment status is displayed with a gray background until the emptying time has not expired.

4.2 Loading

The operations to be performed during loading depend on the configuration of the system.

Due to a different software version and by another configuration, the displays on the measuring system of your vehicle may differ slightly from the displays presented herein.

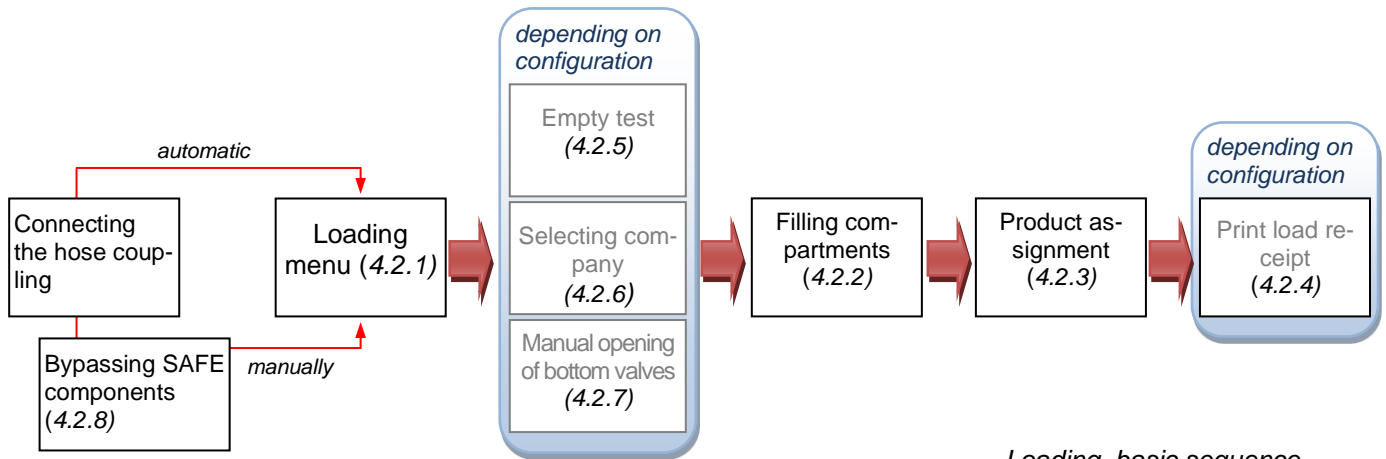

Loading, basic sequence

4.2.1 Loading menu

If the quality control system is active will the loading menu automatically open as soon as you connect the hose for loading and the product code was red. The bottom valves of the compartments where the hose connection is detected are automatically opened (configuration dependent). The lower part of the screen displays the load information.

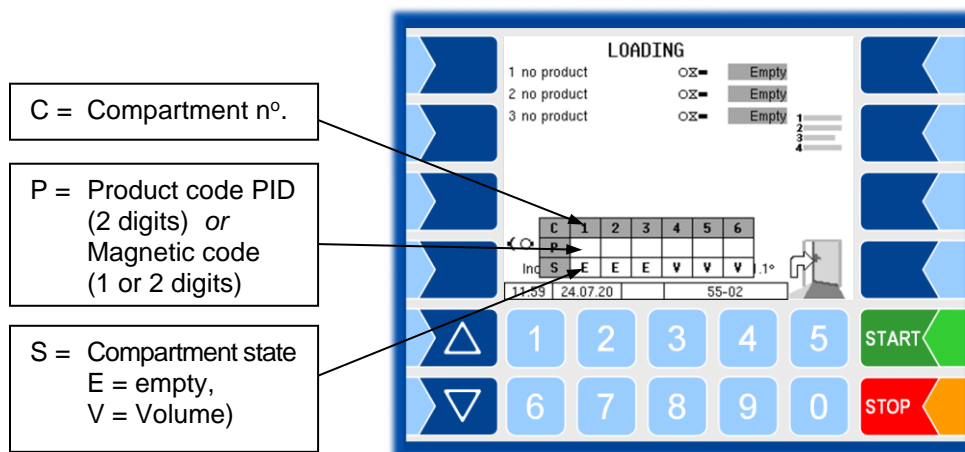

4.2.2 Filling compartments



Depending on configuration the compartment state is printed before each loading.

```

Start Loading
Tourno :-- int.Tourno:55
Start  :05.10.15 16:14:46
Driver  :11
Truck   :1 REG-EN 123
05.10.15
16:15 Start Loading 1 Empty
        Diesel
16:15 Start Loading 2 Empty
        Benzin bleifrei
16:15 Start Loading 3 Empty
        Super bleifrei
    
```

*Example
Compartment state before loading*

- Load the compartments with the respective products in accordance with the Operating Instructions of the vehicle. Once the residual quantity sensor of a compartment is wetted, the detected product is taken over for this compartment.

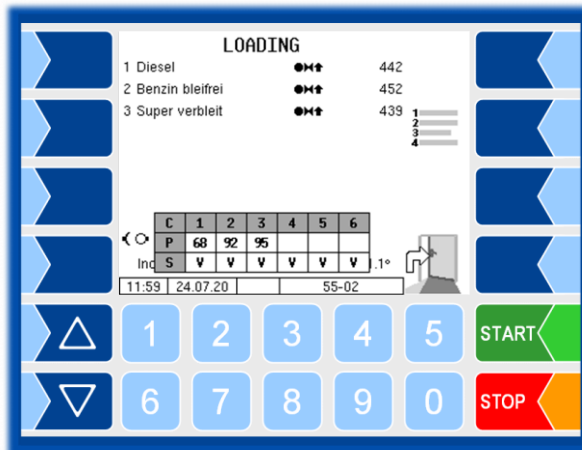

- Disconnect the API coupling, when the compartment is filled.

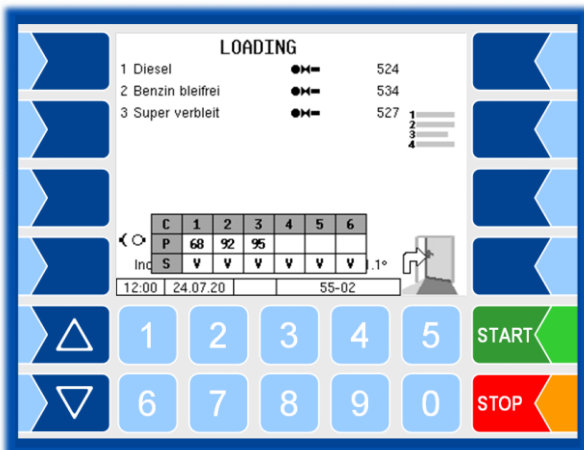

Compartments filled

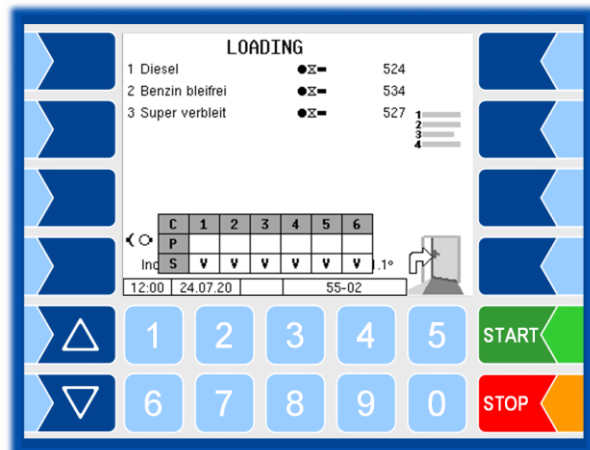

API coupling disconnected

4.2.3 Product assignment

Various products can be loaded under the same product code (e.g. several grades of petrol).

The classification of the products in the compartments you can further specify, in addition to the automatically performed product recognition.

In the Loading menu you can use for this purpose the 2nd Softkey at the right side to call up the *Compartment Product Mapping* window. Here you can assign the products detailed. For further information about Compartment Product Mapping see section 6.6 Load mapping).

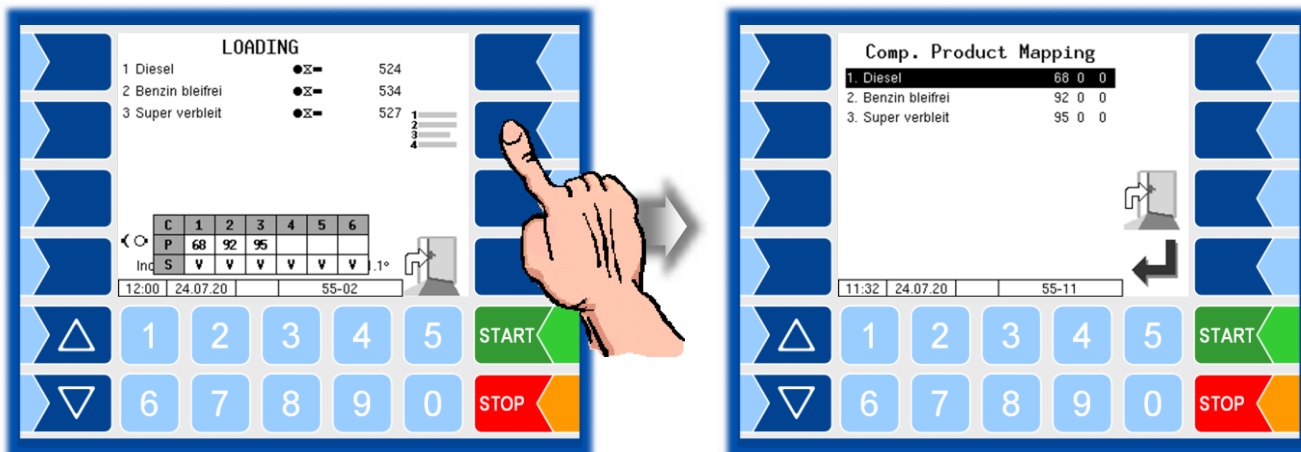

Out of the Loading menu you can open the „Compartment Product Mapping“ window in the Additional Functions menu (see section 6.6).

4.2.4 Print load receipt

When loading is finished and you leave the loading menu the load receipt will be printed if this option is configured.

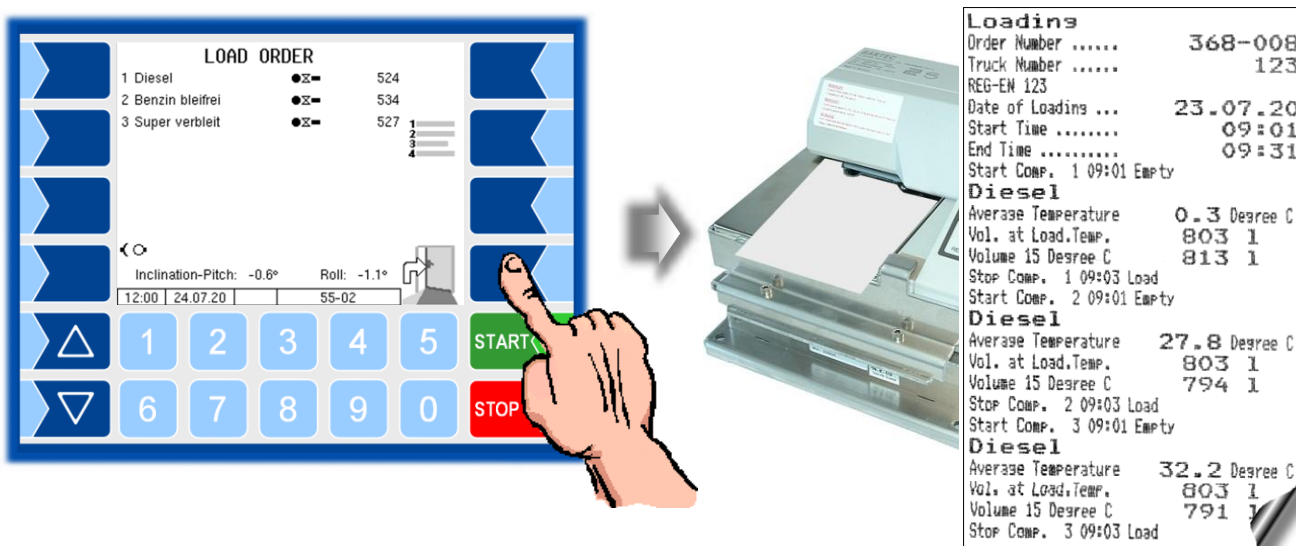

Example Load Receipt

4.2.5 Empty test

When configuring the measuring system, it is possible to specify that loading may only proceed if an empty test takes place within a specified time (*Configuration menu/Control Parameter/ Max. Delay of Empty Test*). If this time has elapsed, the empty test prompt will appear on opening the loading menu.



An empty test may only be run without any hoses connected!

- Press "YES" to start the empty test.

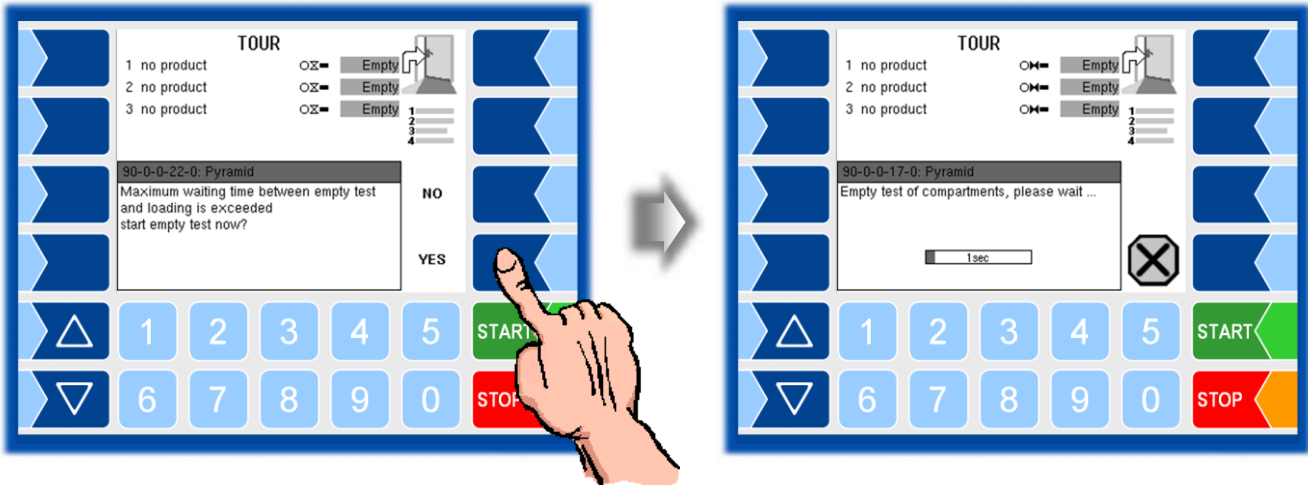

Loading may only proceed if the wetleg sensor is still displaying "empty" at the end of an empty test and no measurement can be registered in the compartment.



The empty test can be omitted if the same product will be loaded and if allowed by the configuration (*Configuration menu/Control Parameter/ Loading onto Rest*).

You can also run an empty test at any other time (cf. section 6.8).

4.2.6 Selecting company



If the vehicle is used to transport products for several oil companies, the company can be selected. The system then applies settings relevant to the company in any given case. Various options can be set for the choice of company when configuring the software (cf. section 6.9).

Automatic company selection prompt

The company selection menu will appear automatically if the configuration dictates that a company has to be selected before the loading process can start. Loading cannot start until the company has been selected.



If loading does not proceed within one hour of the company being selected, the company must be selected again before loading.

It may also be necessary to enter a code for the company selection. Various options can be configured in this regard (cf. section 6.9).

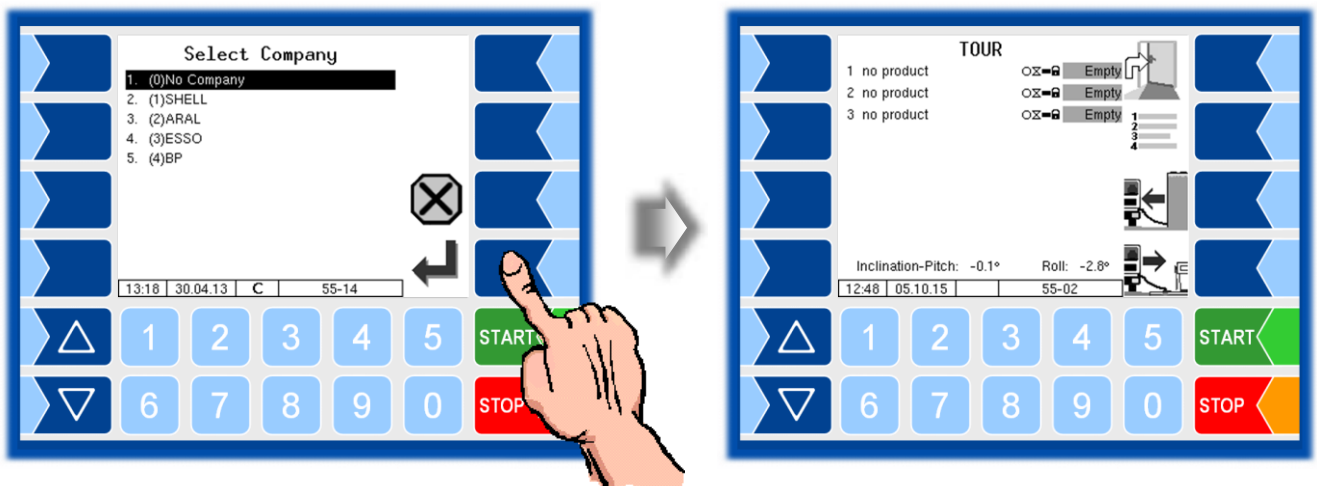

- After selecting the company, open the loading menu again.

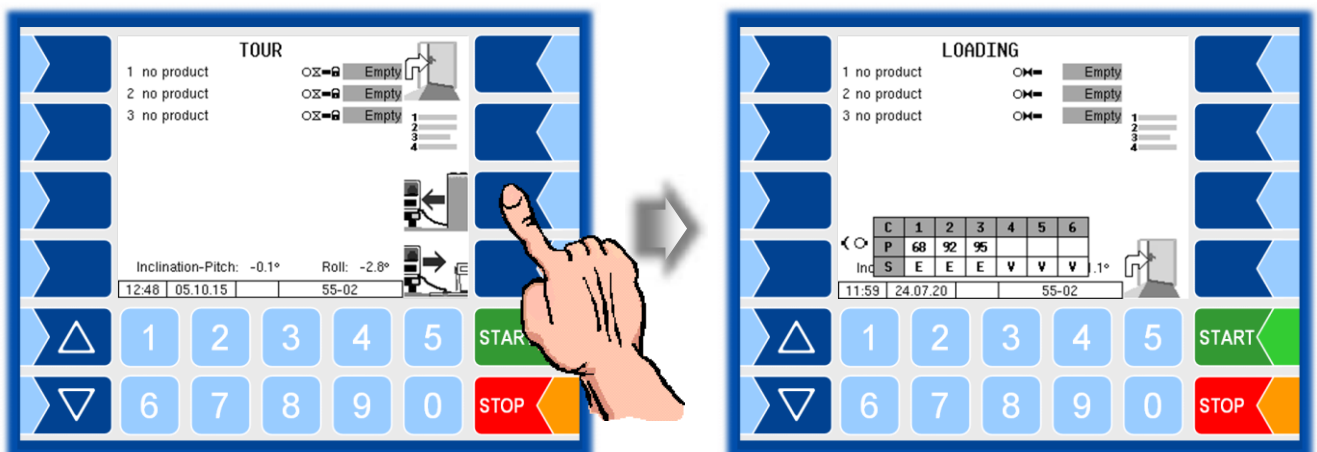

Changing company

- In order to change the company during a tour, you have to access the company selection screen in the menu of additional functions (cf. section 6.9).
- If a default company is set in the Program parameters, will the vehicle automatically be switched to this company as soon as it is empty.

4.2.7 Manual opening of bottom valves

The system can be configured to prevent the bottom valves from opening automatically in order to prevent fluids from leaking even if hoses are not correctly connected.

In this case you have to open the bottom valves manually after checking that the hose coupling is correctly fitted.

- Touch the numerical key corresponding to the number of the compartment on which you want to open the bottom valve.

If you want to load several compartments, you will have to open each of the other relevant bottom valves individually.

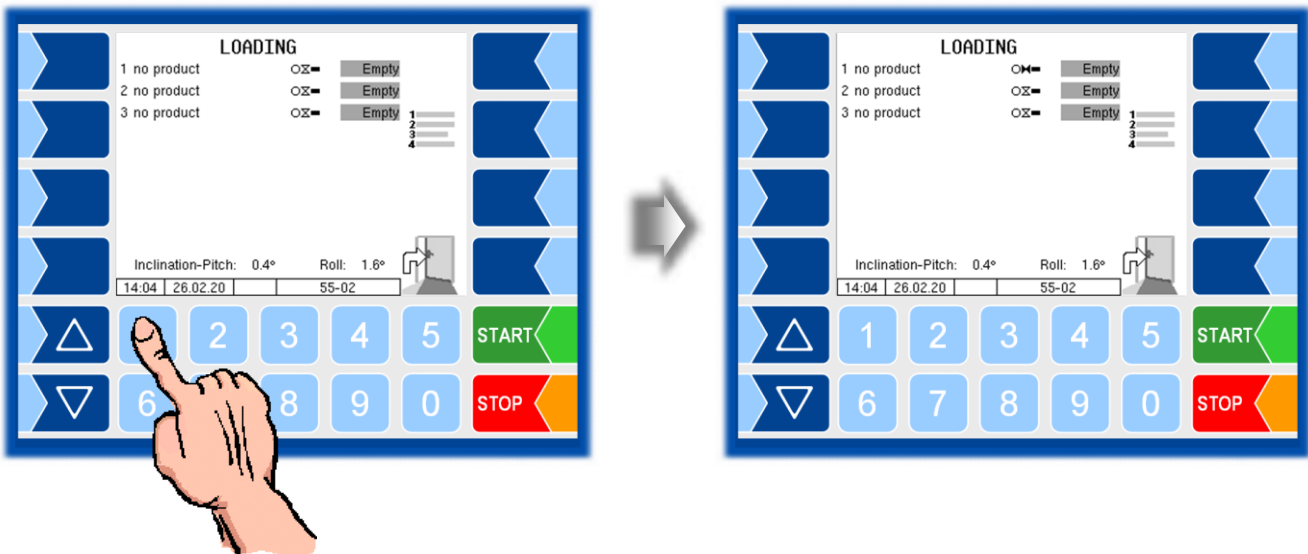

If the "SAFE" system is enabled, a compartment can only be opened if a product code has been duly scanned.

- When the compartments are loaded, close all bottom valves with the **STOP** button.

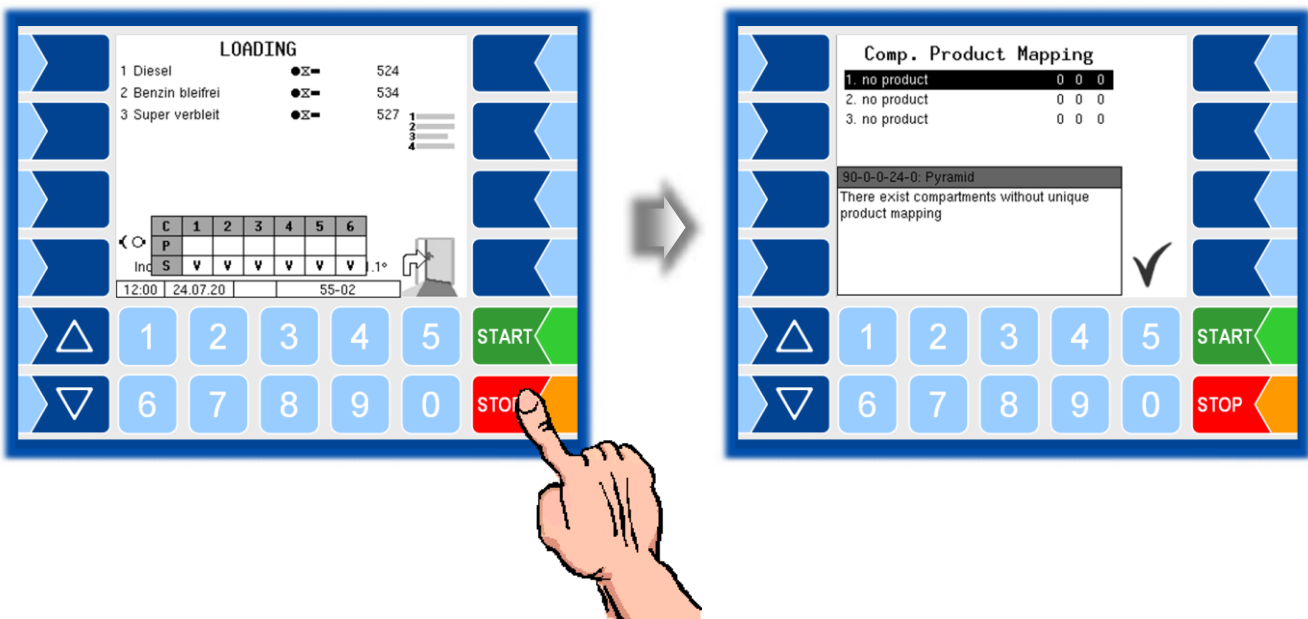

4.2.8 Bypassing SAFE components

(Not applicable to measuring systems without the "SAFE" system)

Manual access to loading menu

You can open the loading menu manually if no product code is scanned (API coupling not correctly fitted, no product code).

- Touch the "Load" softkey. The loading menu will be displayed.

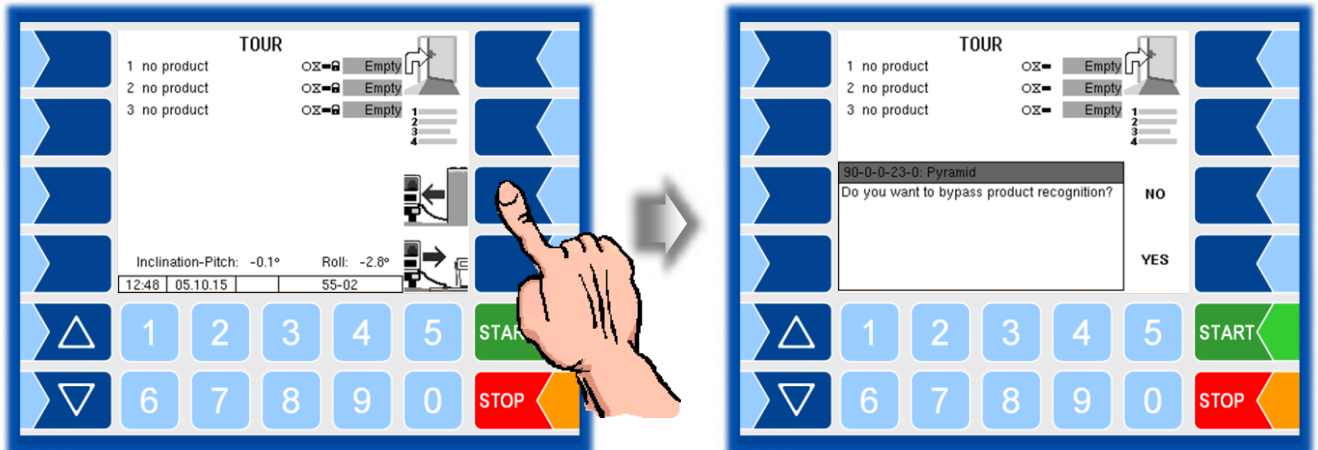

- If you would like to bypass the automatic product code recognition procedure for the loading process, press **YES** in answer to the prompt.

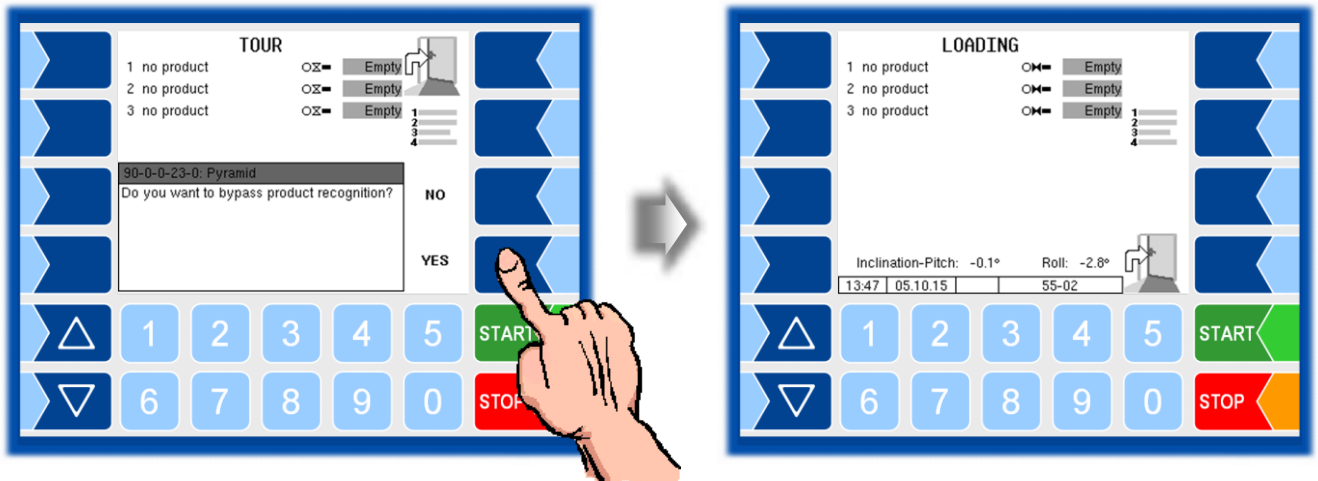

- Load the compartments with the relevant products, as instructed in the vehicle operating manual.

- When the compartments are loaded, press **STOP** to close all the bottom valves.

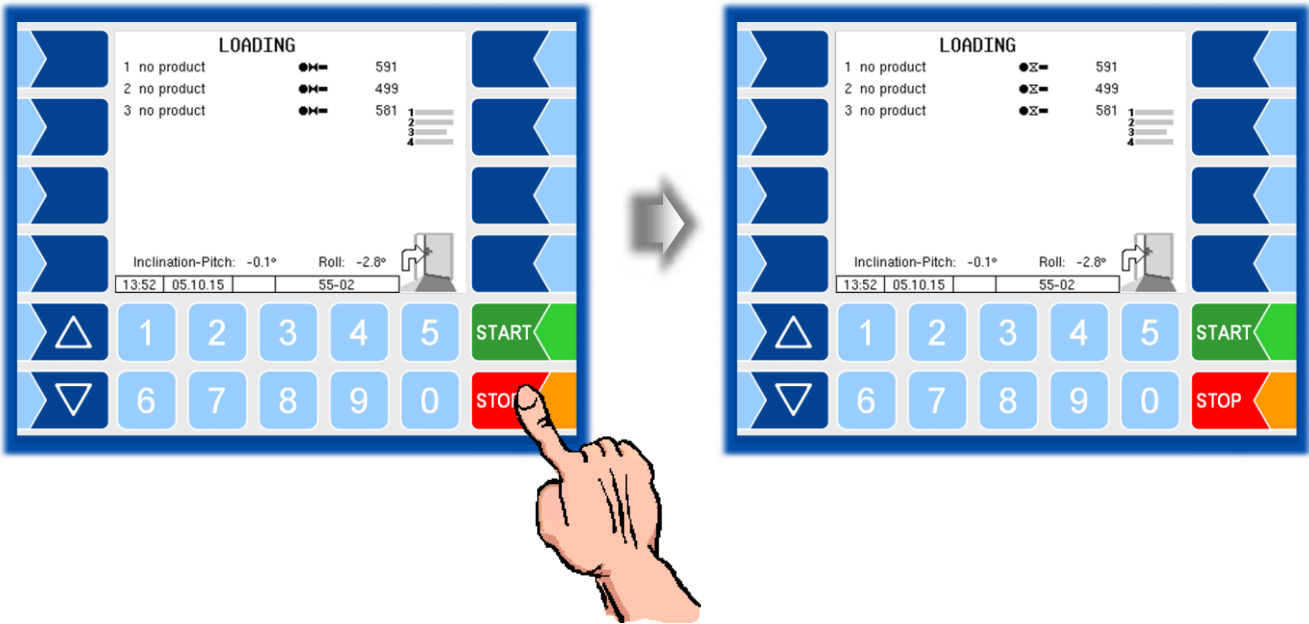

Product mapping

- If you exit the loading menu, a message will be displayed reporting the absence of product allocation.

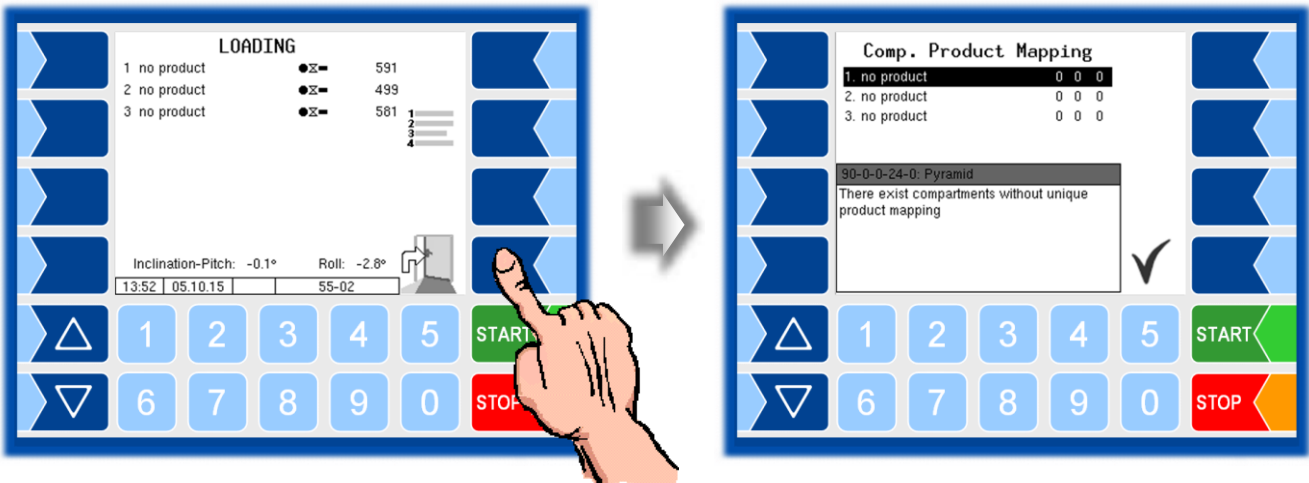

- Confirm receipt of this message.
In the "Comp. Product Mapping" window you can allocate the configured products to the compartment.

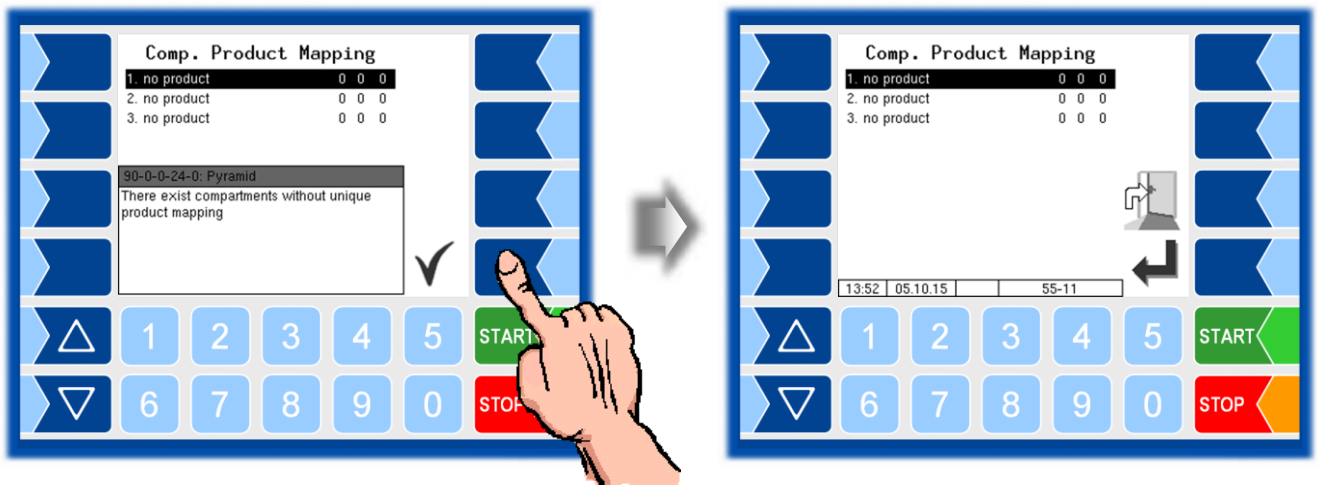

- Select the row for the relevant compartment and touch the "Enter" softkey.

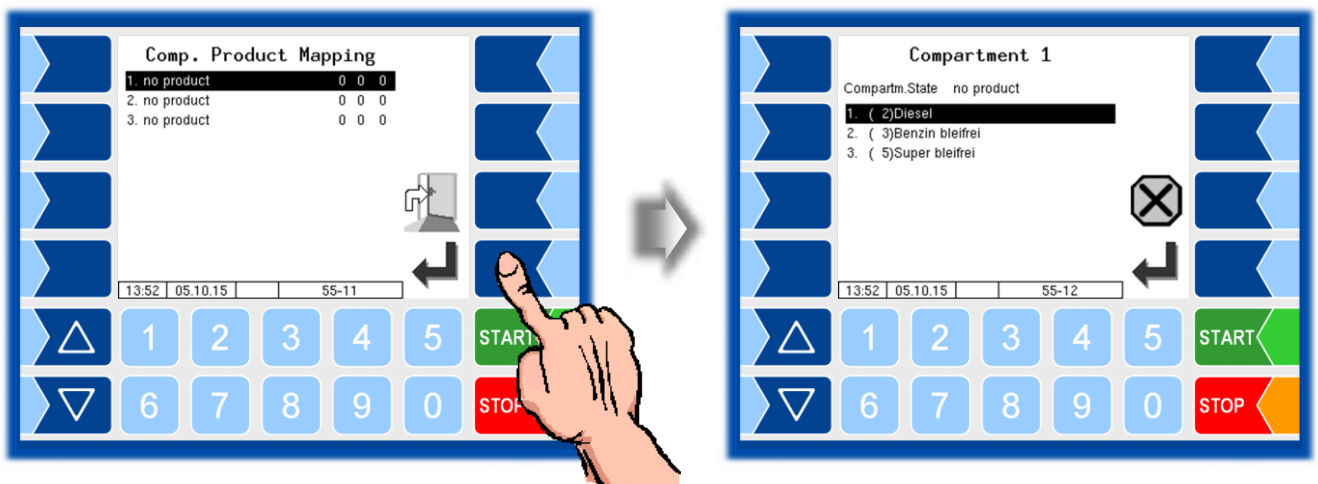

Now you can select the relevant product from all those configured.

- Confirm the product which has been loaded in the compartment.
- Carry out the product allocation process for all loaded compartments.

4.3 Product delivery

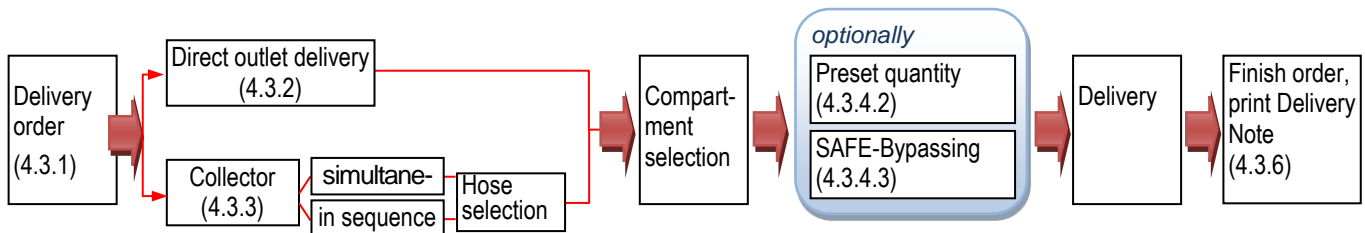

Delivery, basic sequence

4.3.1 Delivery menu

- Open the delivery menu (Window "DELIVERY ORDER").

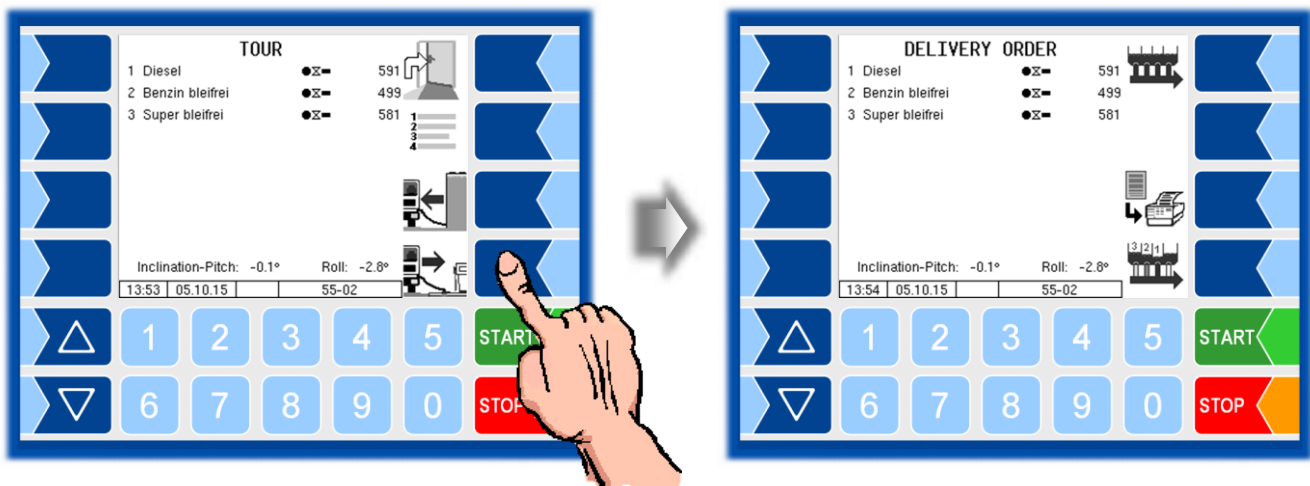

- Then select further delivery options.



Depending on configuration the compartment state is printed before each delivery.

```

Start Delivery
Tourno  :-- int.Tourno:105
Start   :20.10.15 09:00:30
Driver  :11
Truck   :1 REG-EN 123
20.10.15
09:01 Start Delivery 1 Loaded
        Diesel
        sealed
09:01 Start Delivery 2 Loaded
        Diesel
        sealed
09:01 Start Delivery 3 Loaded
        Diesel
        sealed
    
```

Example
Compartment state before delivery

Current delivery data and switching states are displayed during delivery.

Example

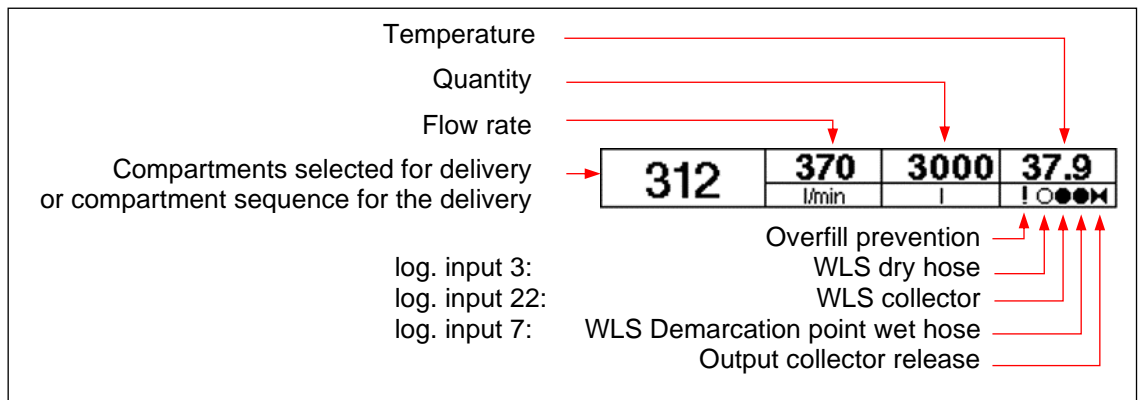

4.3.2 Direct outlet delivery

- Connect the hoses and limit indicator
- Touch the numerical key corresponding to the number of the compartment from which the delivery is to be made.

Information about the safety components is displayed on the delivery screen (cf. section 4.3.4.3).

(Not applicable to measuring systems without the "SAFE" system)

"SAFE" system information

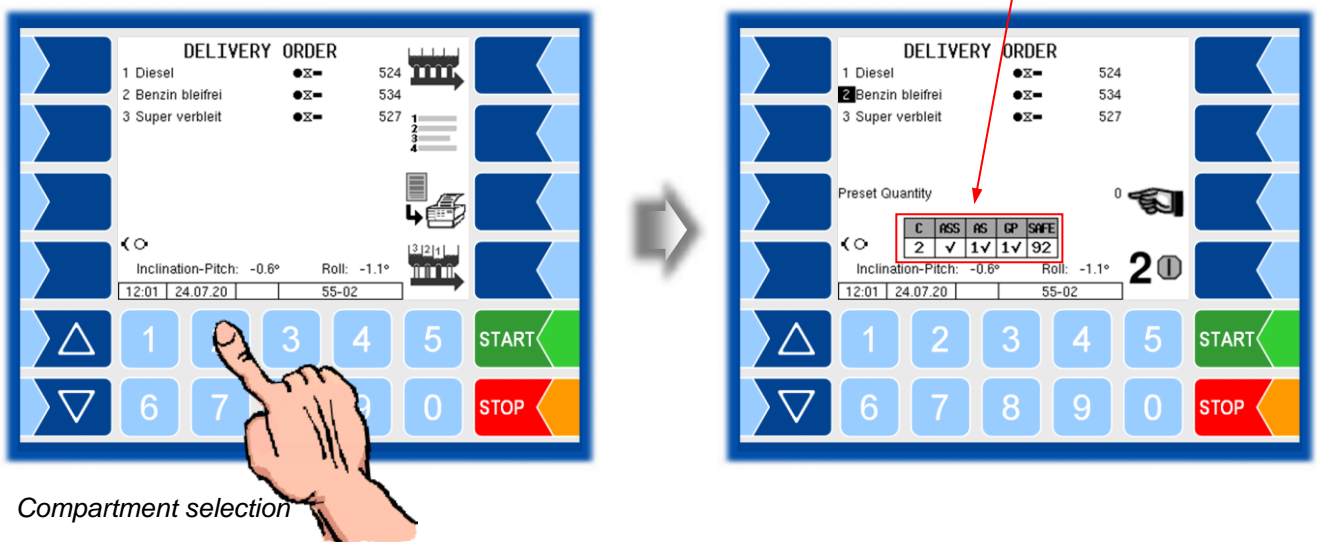

Compartment selection

You have the option of entering a preset quantity for delivery (cf. section 4.3.4.2).

- Press "Start delivery" for the compartment selected.

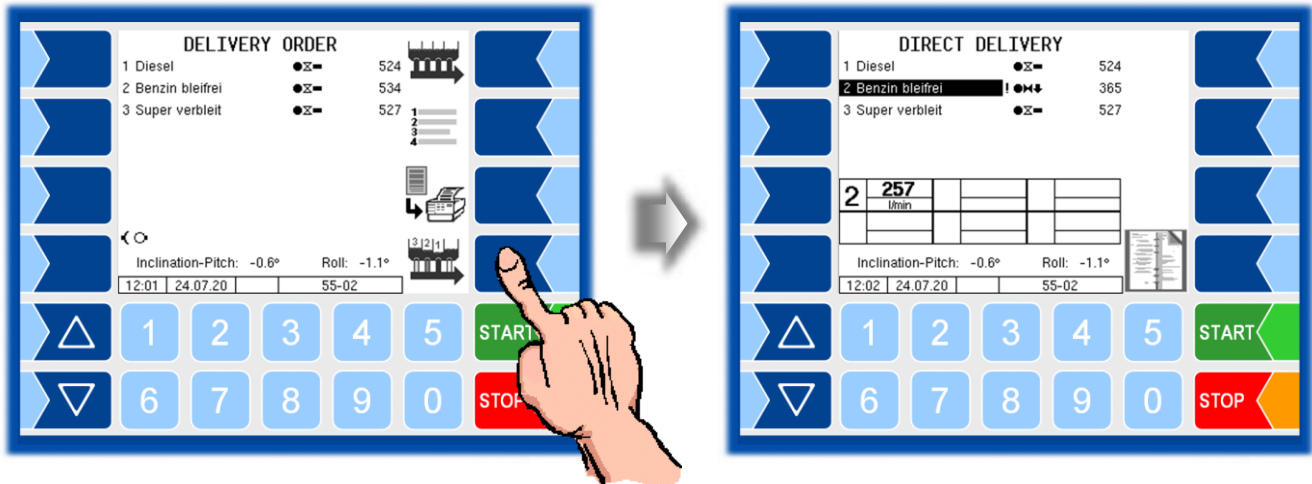

- Carry out the delivery process as instructed in the vehicle operating manual.



Proceed as above to start further deliveries from other compartments.

You can interrupt and resume deliveries by pressing the numerical keys corresponding to the compartment numbers.

Press **STOP** to interrupt all deliveries. The delivery processes then have to be resumed individually for each compartment.

If the float gauge has reached the section which is out of the measurement range and the wetleg sensor is not wet, the compartment status will be displayed as "Rest" in place of the quantity. If the wetleg sensor is wet, the maximum possible amount will be highlighted in grey in the section which is out of the measurement range.

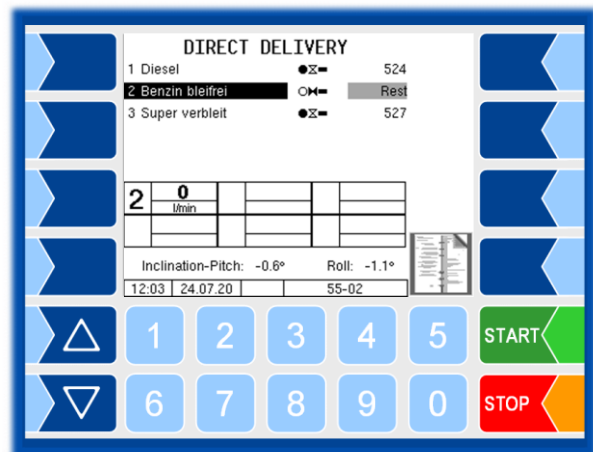

After the compartment has drained completely (end of configured time), the compartment status will read "Empty".

4.3.3 Collector delivery

(Not applicable to measuring systems without a collector.)

- After opening the delivery menu, you can choose whether the delivery is to proceed from several compartments at the same time or consecutively in a certain order which can be selected.

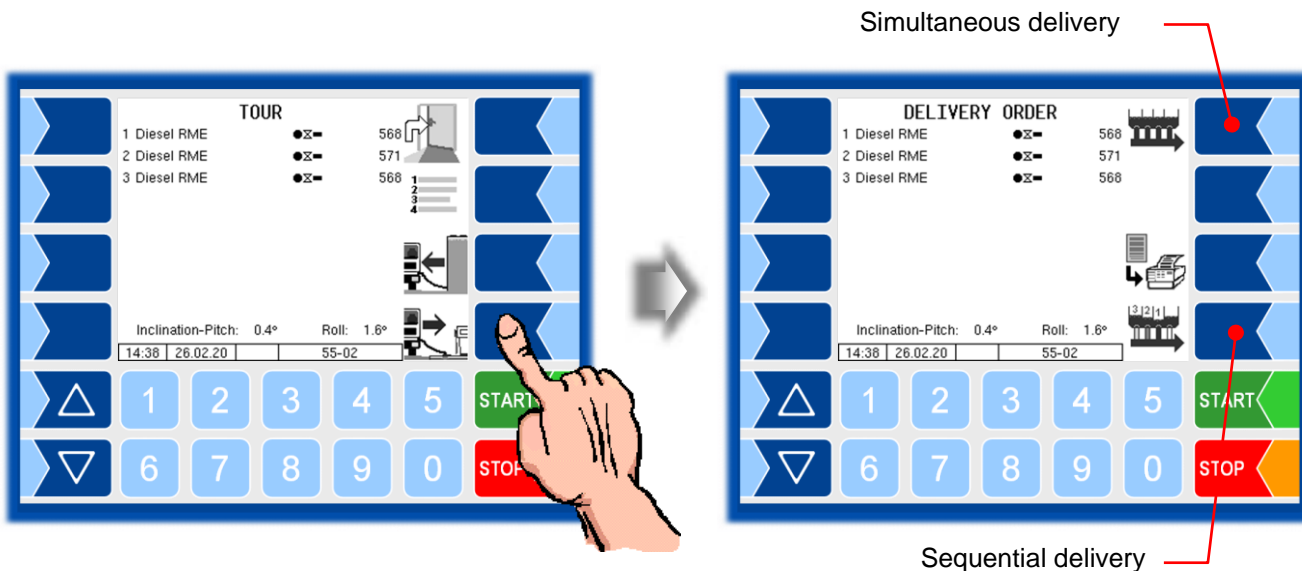

4.3.3.1 Simultaneous delivery from several compartments

- After opting for "Simultaneous delivery", select the hose.

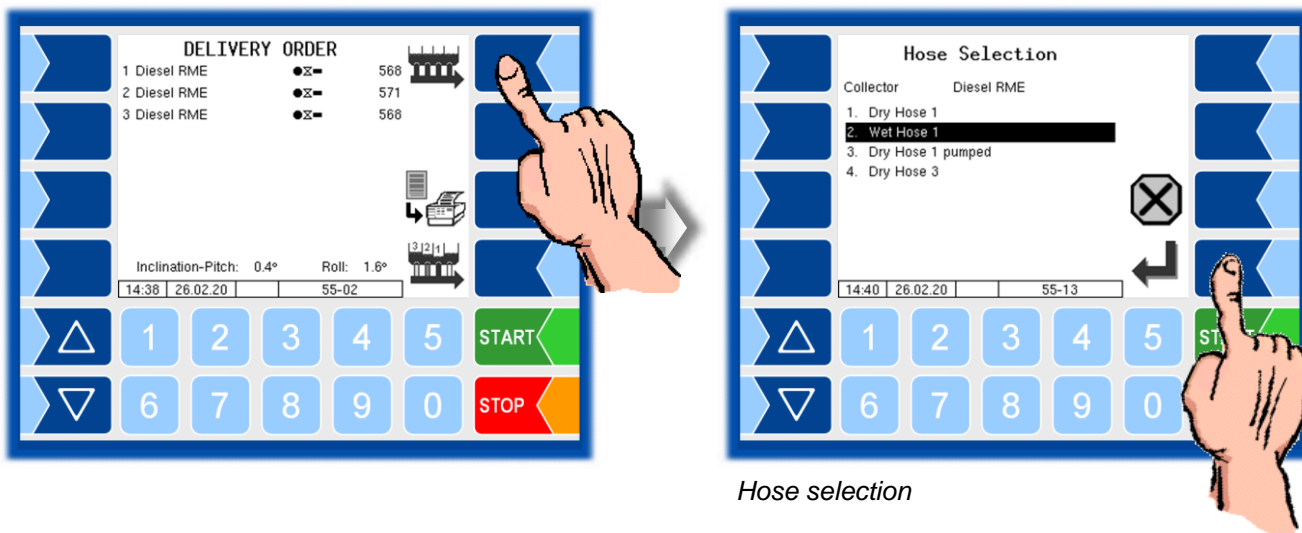

Wet hose deliveries proceed without quality control system!

- Enter the numbers of the compartments from which delivery is to take place.

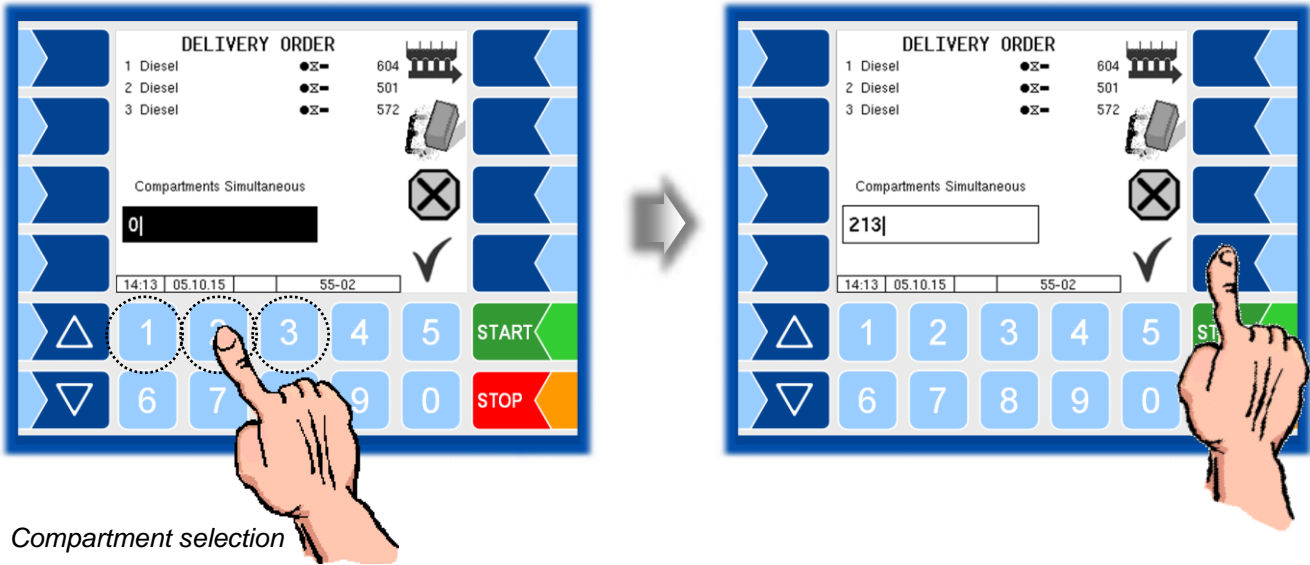

Compartment selection

You have the option of entering a preset quantity for delivery (cf. section 4.3.4.2).

- Connect the delivery hose.
- Confirm the compartment numbers for the product delivery.
- Information about the safety components is displayed on the delivery screen (cf. section 4.3.4.3).

"SAFE" system information

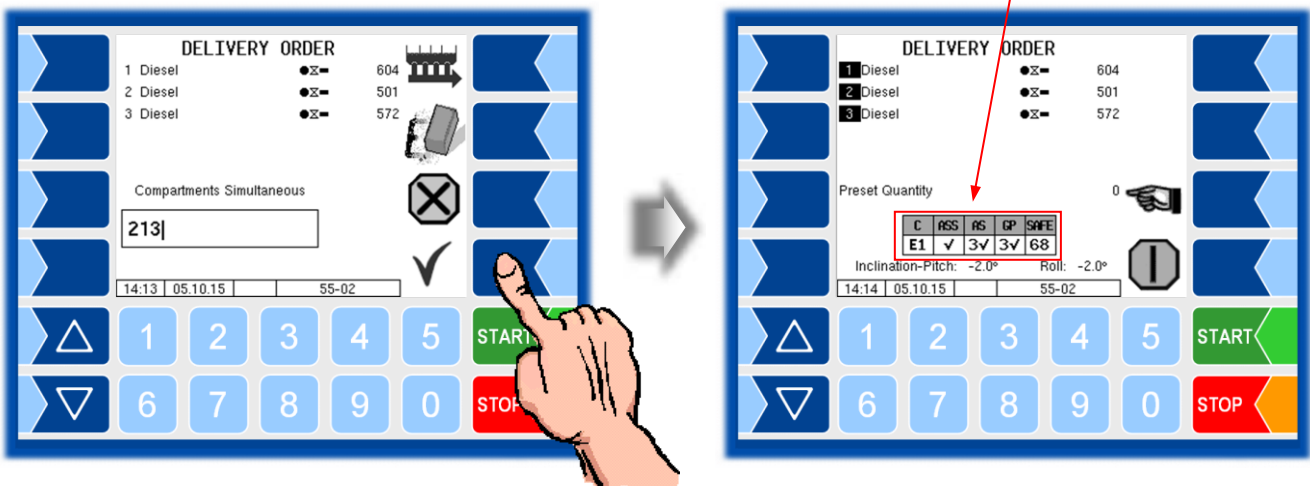

- Press "Start delivery" softkey for the compartments selected.

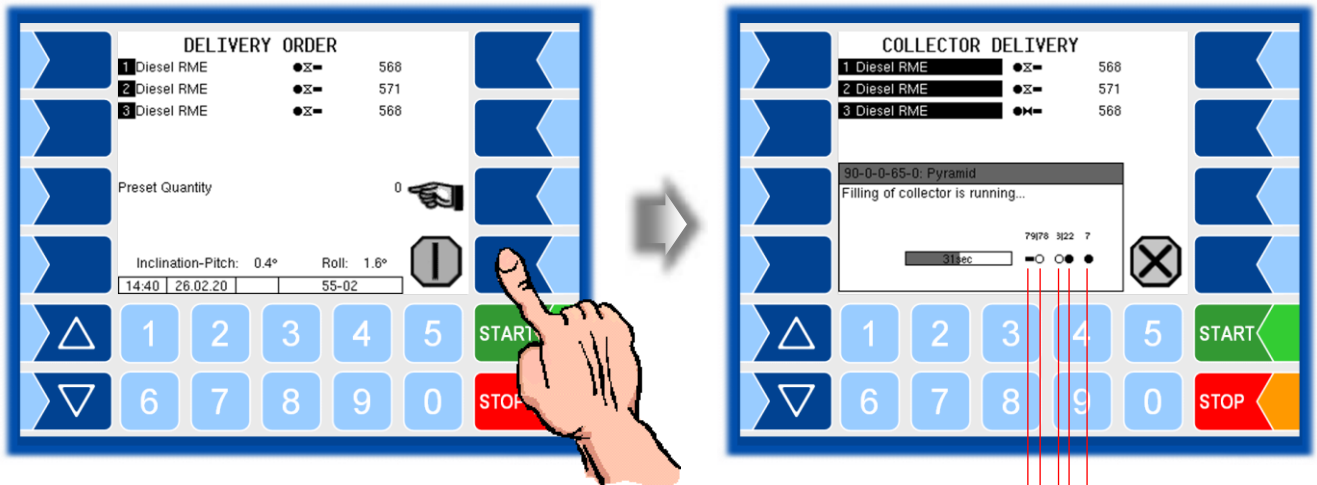

WLS status display: Gravity delivery via Dry hose 4
 Gravity delivery via Dry hose 3
 Dry hose
 Collector
 Demarcation point Wet hose

The collector is filled and the delivery process begins.
 The progression of the collector filling process is shown in the display by means of a time bar, and the status of the wetleg sensors is displayed.

Wetleg sensor status display

- not wet
- wet
- not installed



The filling of the collector does not apply to deliveries over a dry hose.

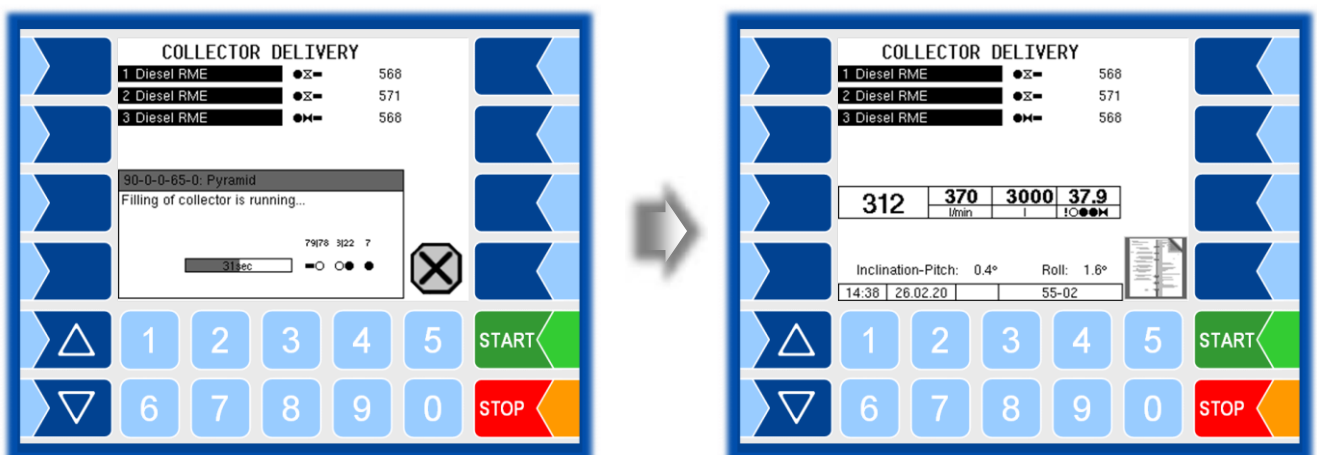

The collector is automatically emptied after the compartments have been drained. The progression of the collector emptying process is shown in the display by means of a time bar, and the status of the wetleg sensors is displayed.

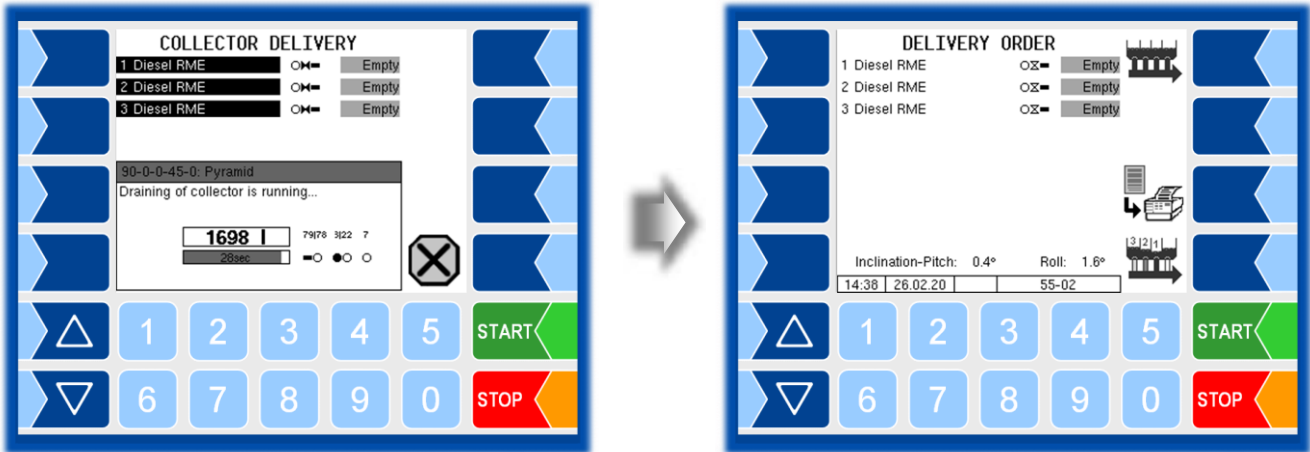

4.3.3.2

Consecutive delivery from several compartments

- After opting for "Consecutive delivery", select the hose.

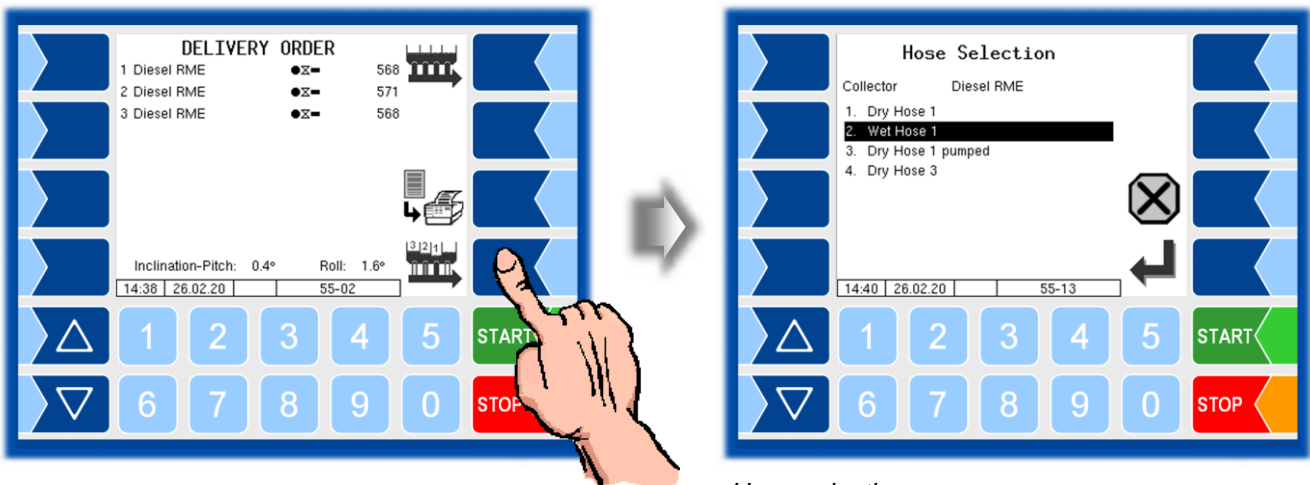

Hose selection



Wet hose deliveries proceed without quality control system!

- Enter the numbers of the compartments in the order in which delivery is to proceed from these compartments.

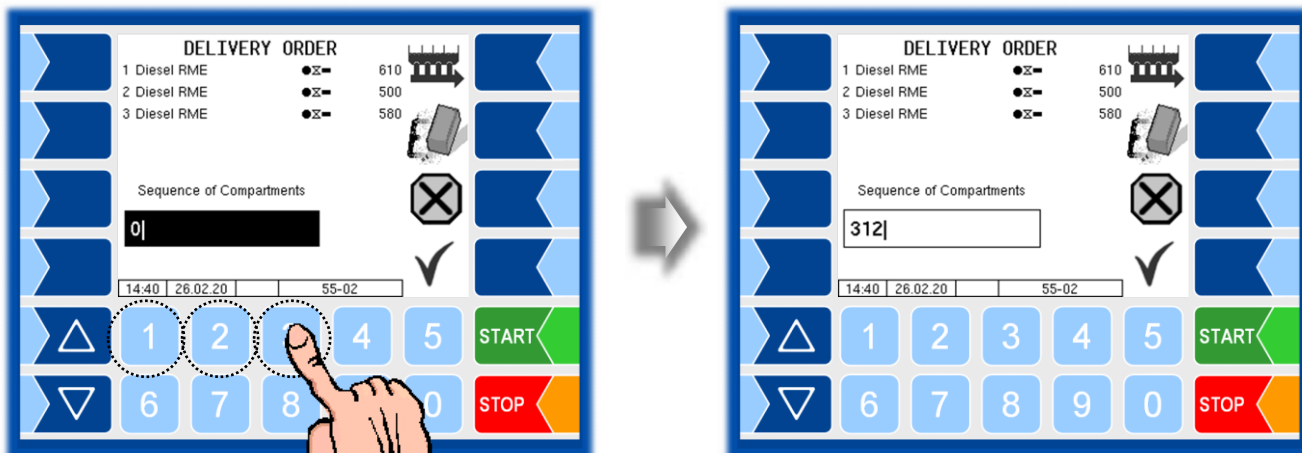

Compartment selection

You have the option of entering a preset quantity for delivery (cf. section 4.3.4.2).

- Connect the delivery hose.
- Confirm the order of the compartment numbers for the product delivery. Information about the safety components is displayed on the delivery screen (cf. section 4.3.4.3).

"SAFE" system information

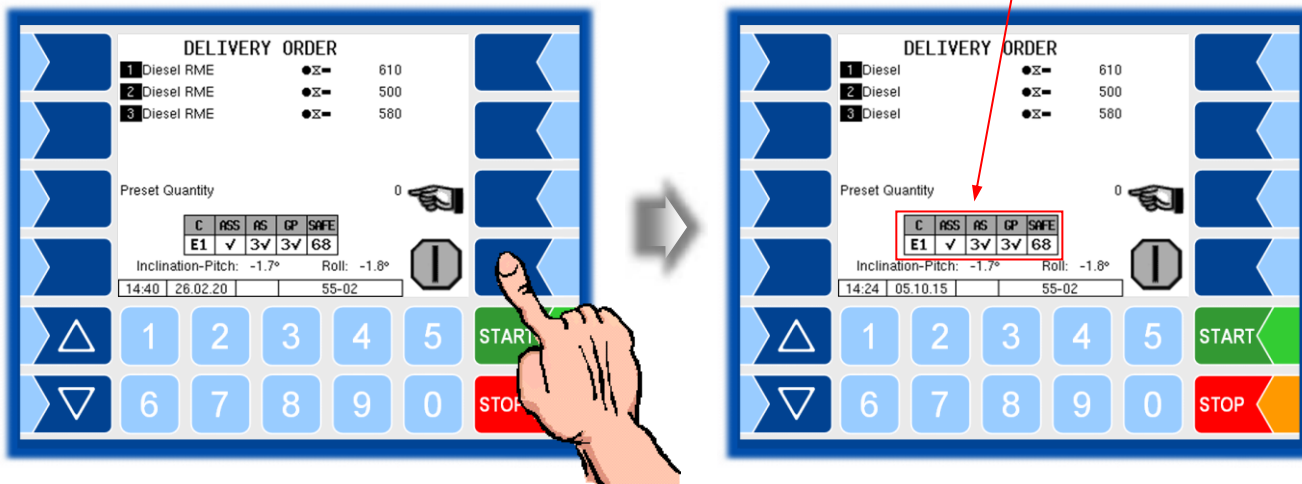

- Press "Start delivery" for the compartments selected.

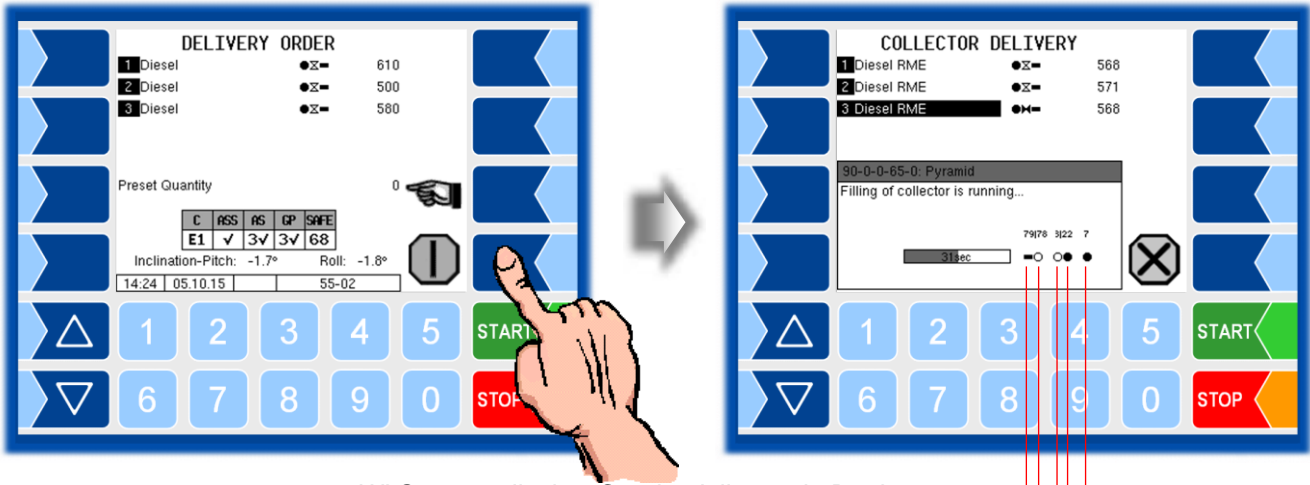

WLS status display: Gravity delivery via Dry hose 4
 Gravity delivery via Dry hose 3
 Dry hose
 Collector
 Demarcation point Wet hose

The collector is filled and the delivery process begins. The progression of the collector filling process is shown in the display by means of a time bar, and the status of the wetleg sensors is displayed.

Wetleg sensor status display

- not wet
- wet
- not installed



The filling of the collector does not apply to deliveries over a dry hose.

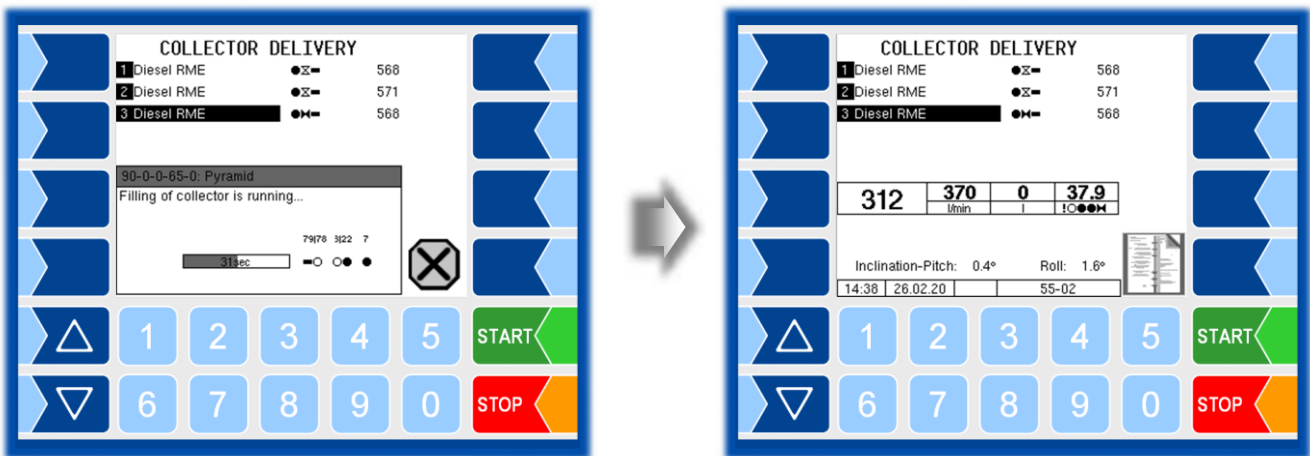

The compartments are emptied in the order specified.

The collector is automatically emptied after the compartments have been drained. The progression of the collector emptying process is shown in the display by means of a time bar, and the status of the wetleg sensors is displayed.

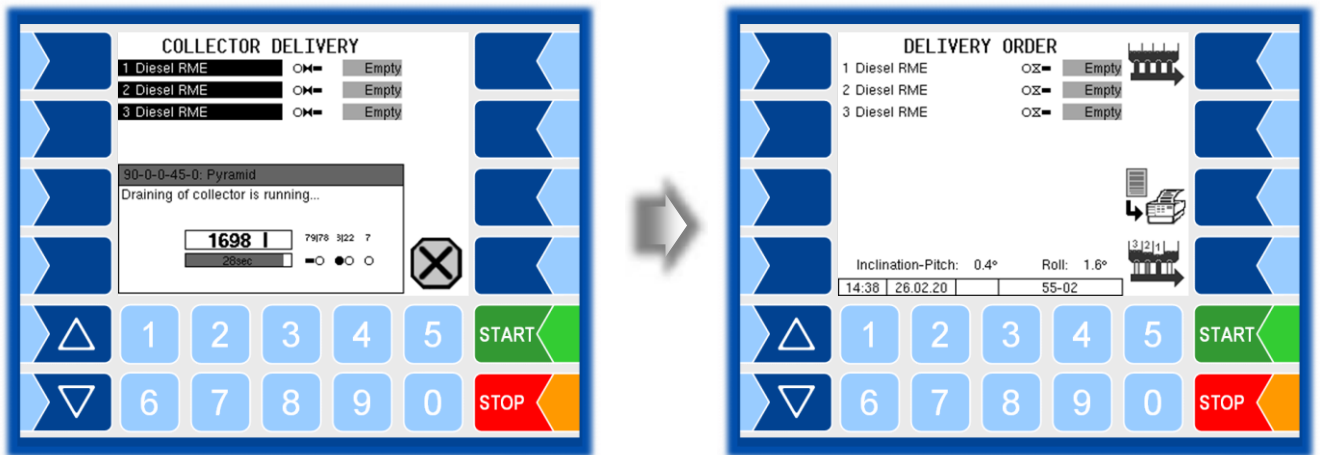

4.3.3.3 Part delivery

If compartments have only been partially emptied during the delivery process, you can end the delivery process as "calibrated" or "uncalibrated".

"Calibrated" end to delivery process

If the collector is not empty, you will be asked about draining the system. If you answer "YES", the collector will be emptied and the end to the delivery process will be "calibrated".

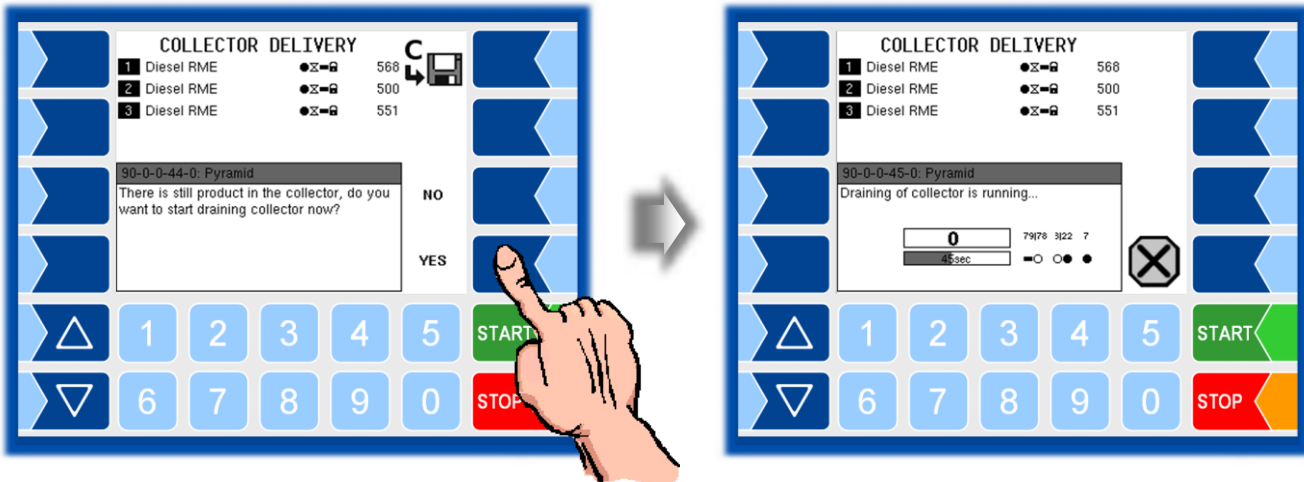

"Uncalibrated" end to delivery process

If you press "NO", you will be prompted again as to whether your final decision is for a "calibrated" or "uncalibrated" end to the delivery.

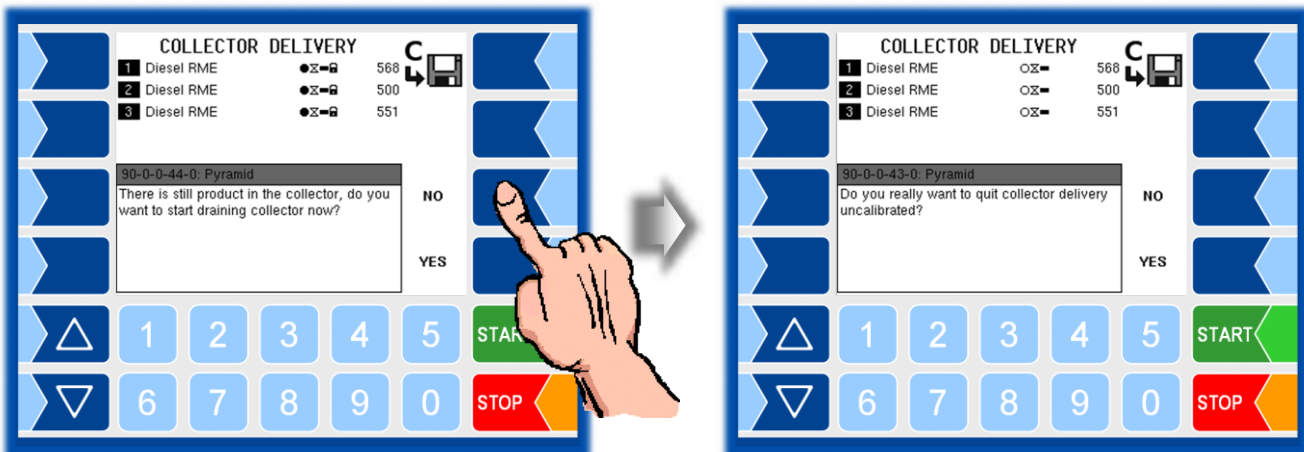

If you answer "YES", the collector will not be emptied and the end to the delivery process will be "uncalibrated".

Press "NO" to return to the previous screen.

4.3.4 Functions during the delivery process

4.3.4.1 Displaying delivery information

You can access detailed information on the current deliveries. Touch the "Page change" softkey to move to the second or third page of the delivery menu.

The second page is not displayed when processing a collector delivery!

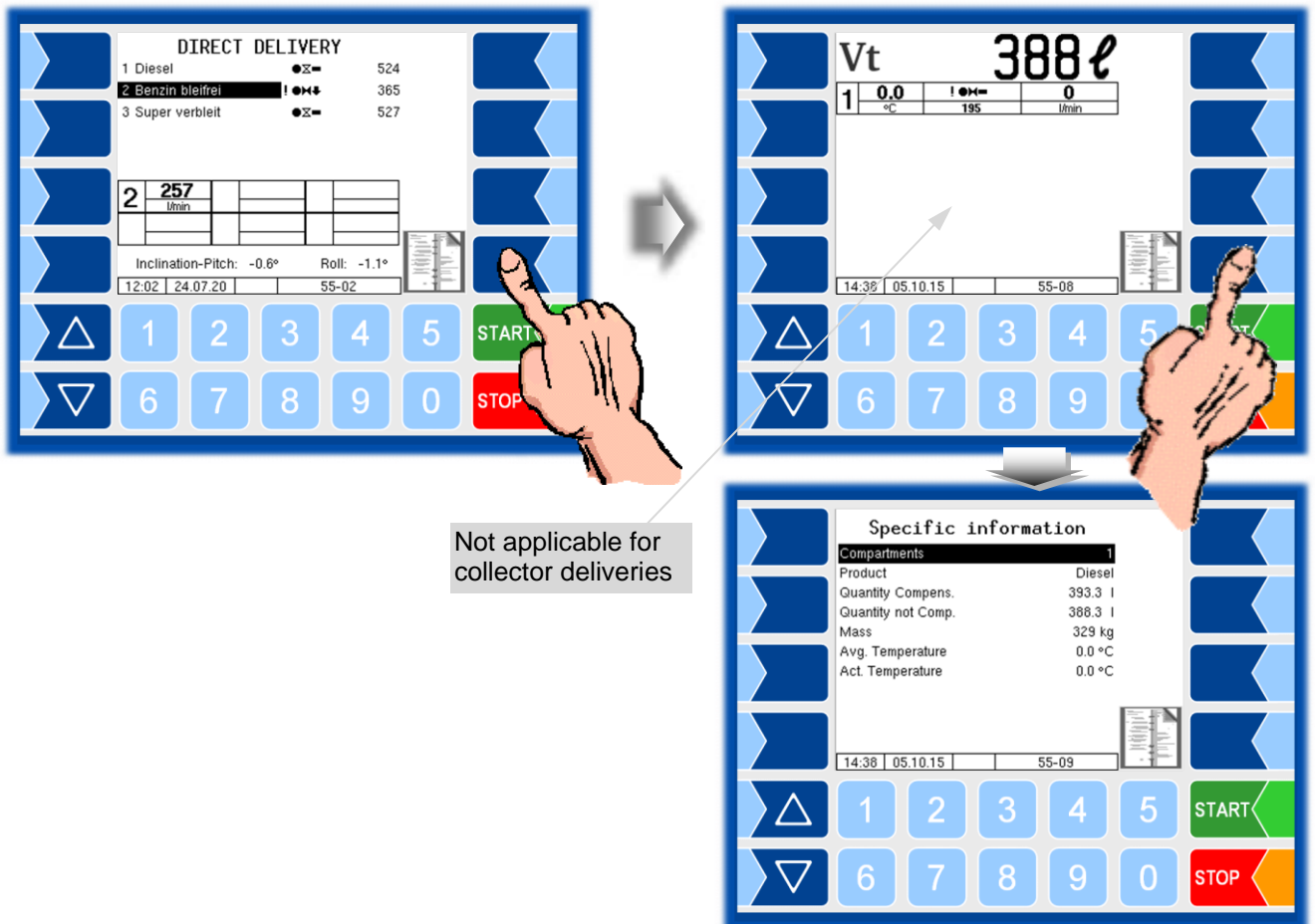

4.3.4.2 Preset quantity

You can set the delivery to stop automatically on reaching a preset quantity.

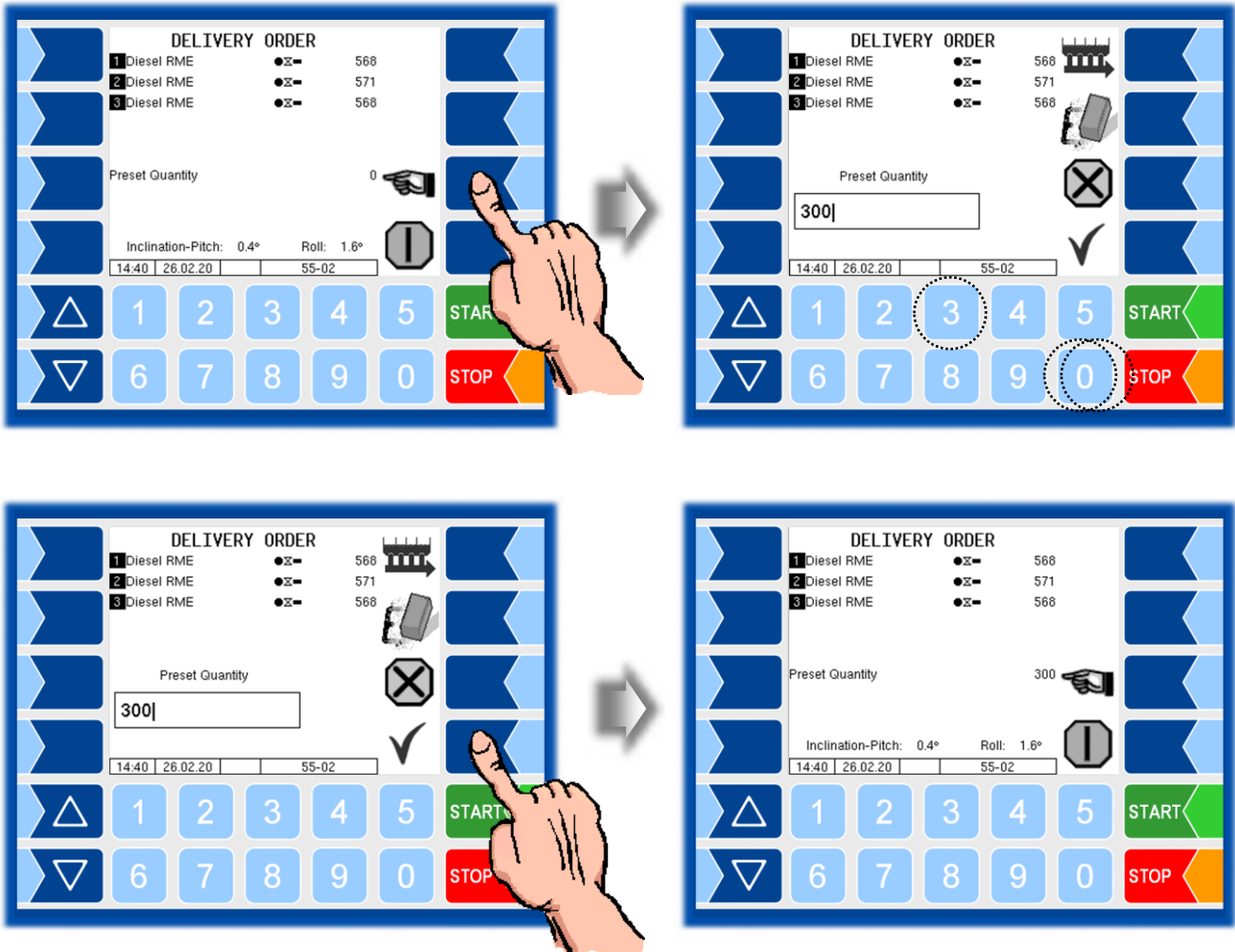

4.3.4.3



Quality assurance system „SAFE 3003“

(Not applicable to measuring systems without the "SAFE 3003" system)

The ticks in the boxes on the delivery screen identify the safety components.

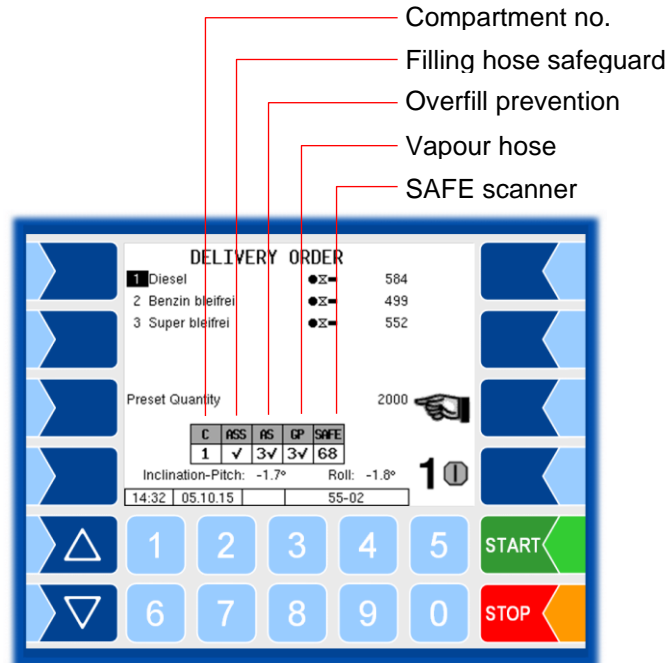

If the relevant safety components are not identified, the boxes contain a question mark instead of a tick and the [?] softkey is displayed. Press this softkey for information on the absent SAFE components. Once the message has been acknowledged, the next message will appear, where applicable.

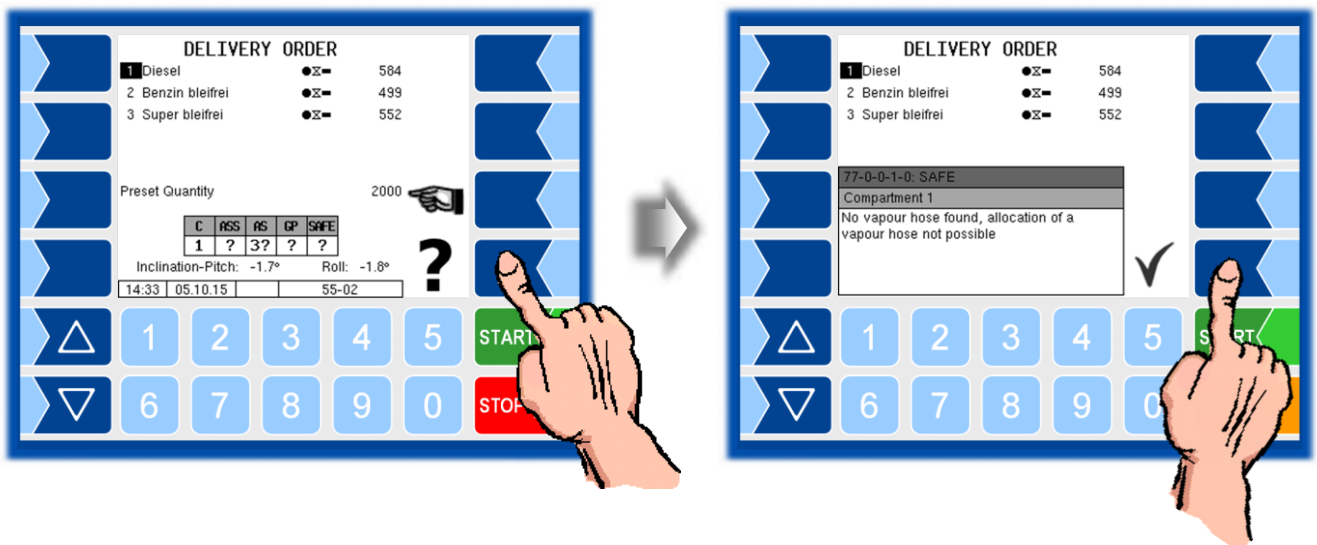

Any SAFE components which are unavailable must be bypassed to enable delivery.

Bypassing SAFE components

If one or more components of the quality control system cannot be identified when you are about to start a delivery, you can choose to bypass these components and start the delivery if the configuration allows. Any bypass action is logged.

In the following example there is no gas back venting hose for compartment 1.

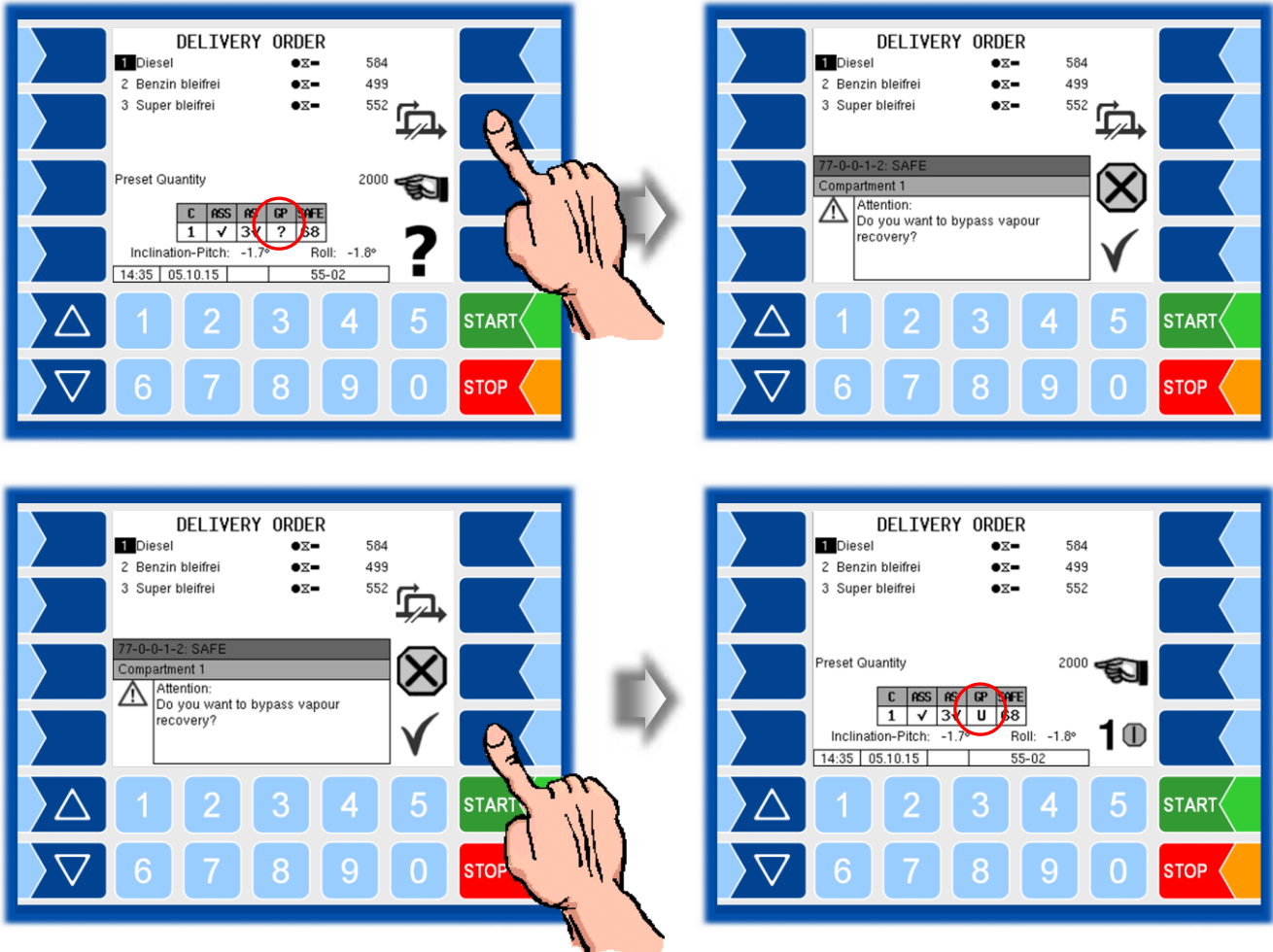

4.3.5 Delivery with optical overfill prevention (Switzerland)

An optical overfill prevention system is used in Switzerland instead of the thermal overfill prevention system.

This does not fundamentally alter the product delivery process.

This section explains the special features of delivery with optical overfill prevention.

- Before starting the delivery, plug the overfill prevention limit indicator connector in the socket of the tank which is to be filled.

If no limit indicator plug is detected, a message to this effect will appear in the display.

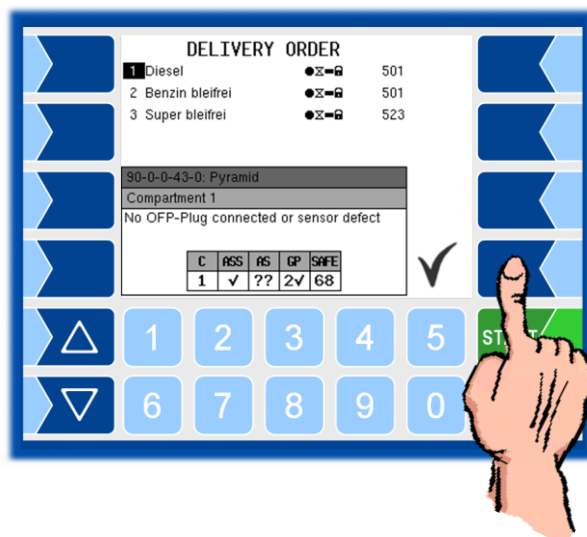

- Establish the absent connection and confirm receipt of the message.
- Press "Start delivery" for the compartment selected.

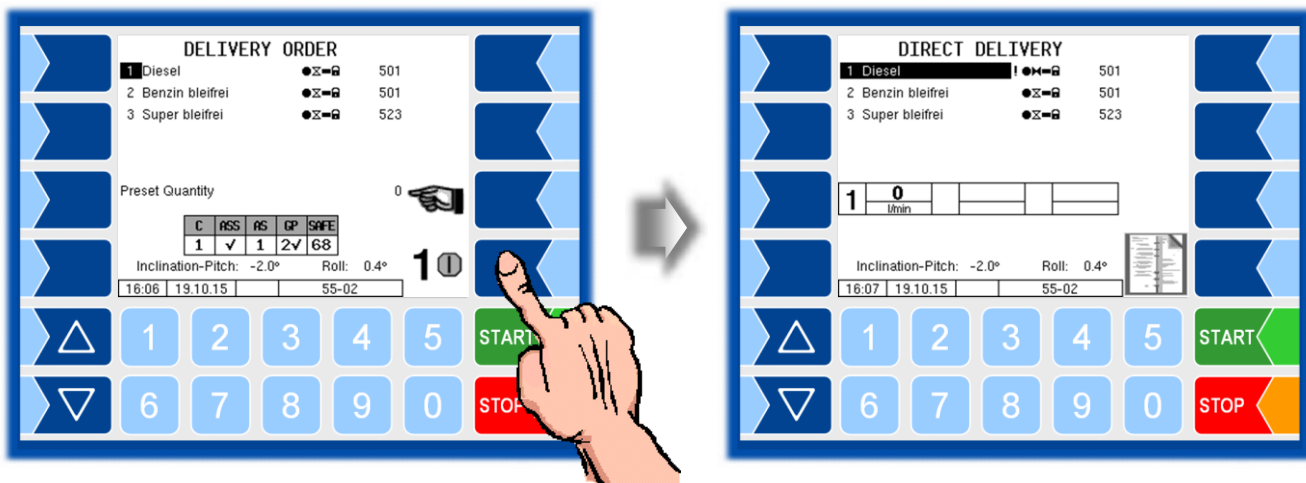

- Carry out the delivery process as instructed in the vehicle operating manual.

The delivery process will stop when the overfill prevention is activated. A message will appear in the display that the tank is full. A warning signal will sound if a horn alert is configured.

- You can switch off the signal with a softkey on the controller.

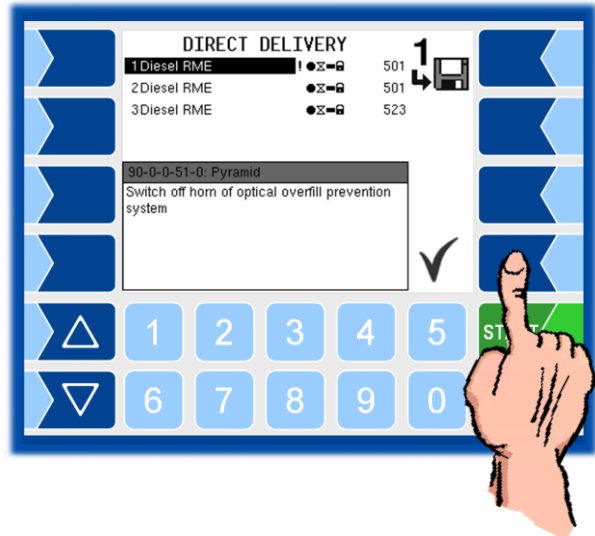

- Confirm receipt of the message that the tank is full.

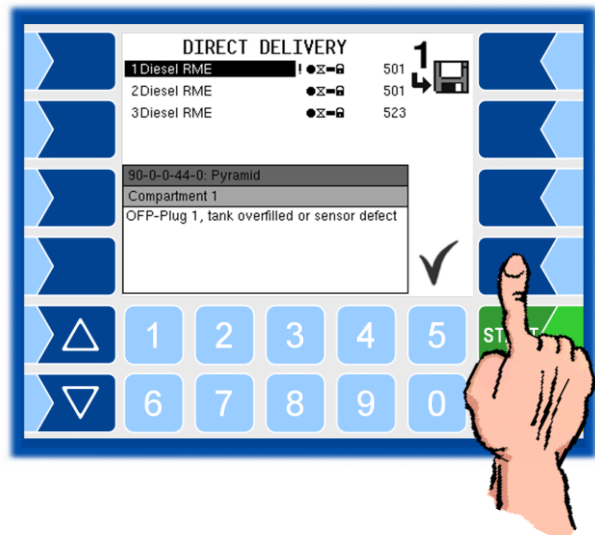

- If you want to continue delivery into another tank, move the delivery hose to this tank and plug the overfill prevention limit indicator connector to this tank.

A prompt will appear to ensure that the product will continue to be delivered from the same compartment.

- Check the limit indicator plug is correctly connected and press "YES" to confirm.

Only then can the delivery process be continued.

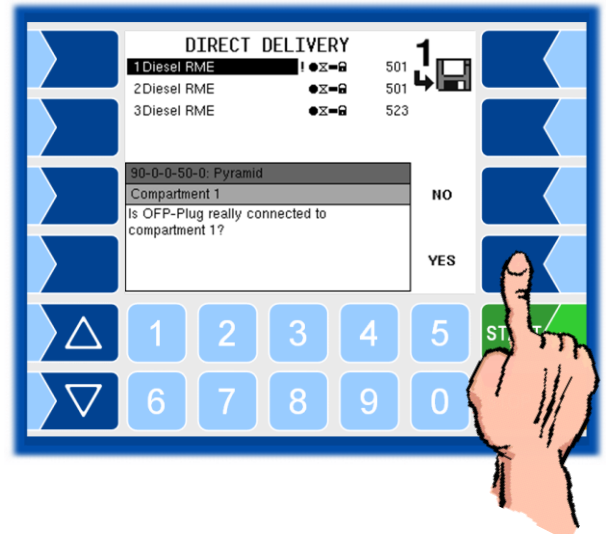

Bypassing the optical overfill prevention

You can bypass the overfill prevention if problems arise or if there is no overfill prevention system installed on the tank.

- Park the limit indicator plug in the socket on the vehicle.
- You need to confirm the bypass option before you can start the delivery process.

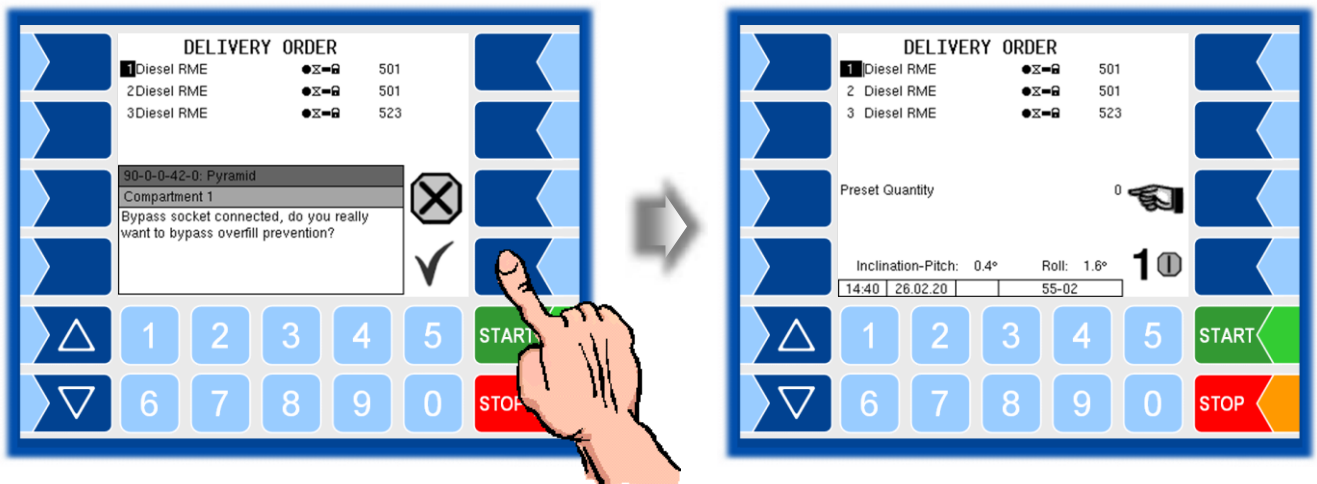

The overfill prevention bypass is recorded in the log!



The tanker driver is responsible for preventing tanks from overflowing if proceeding with delivery without overfill prevention!

If the delivery with bypass is not completed within five minutes, the delivery will be stopped automatically.

- Confirm receipt of the message in the display.

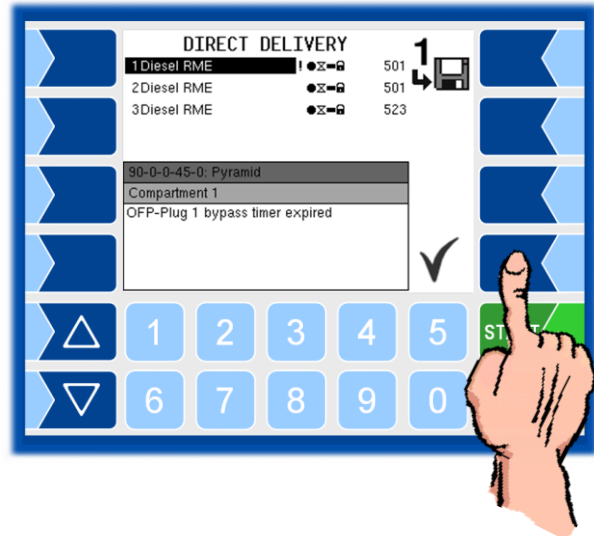

- In order to resume the delivery, you have to select the compartment again and start the delivery.

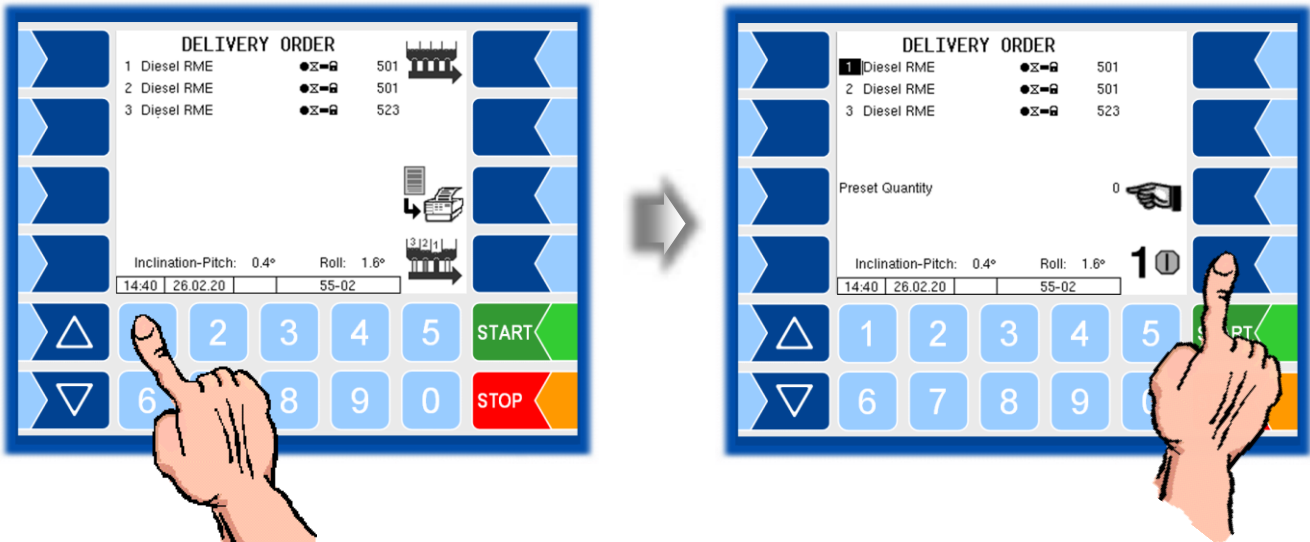

The bypass will be activated for another five minutes.

4.3.6 Finishing orders

- To stop delivery from a certain compartment, touch the corresponding number on the keypad, or touch **STOP** to stop all deliveries. You can then save the delivery data.

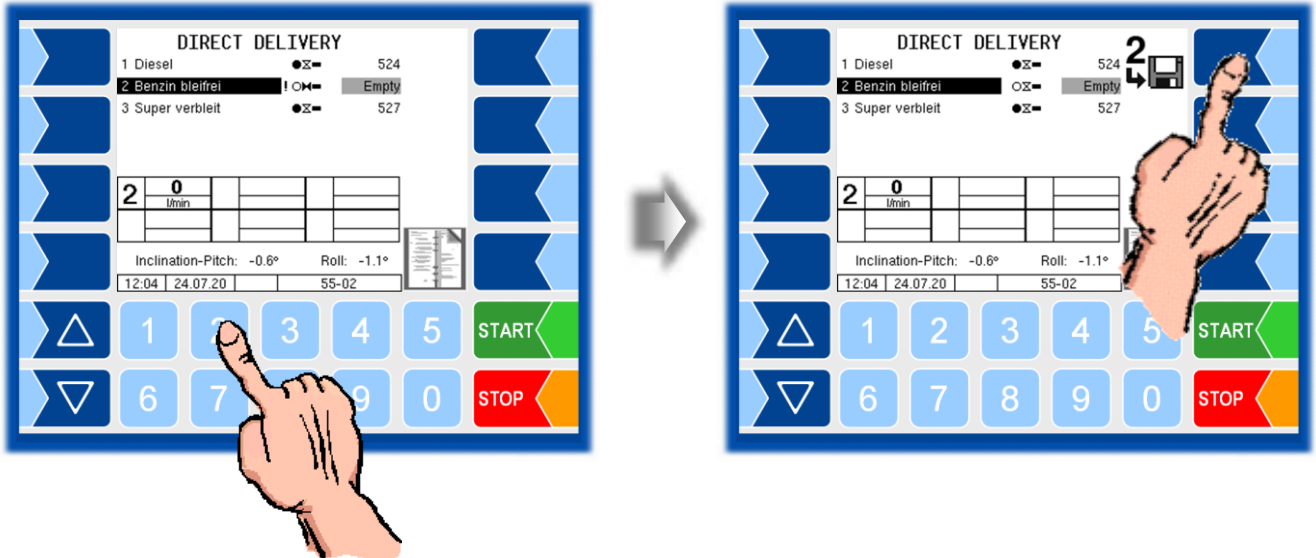

After you have saved all the delivery data, the delivery screen will be closed.

- Touch "Finish order, print receipt" to finish the order. If several receipts are configured, the delivery note selection will follow.

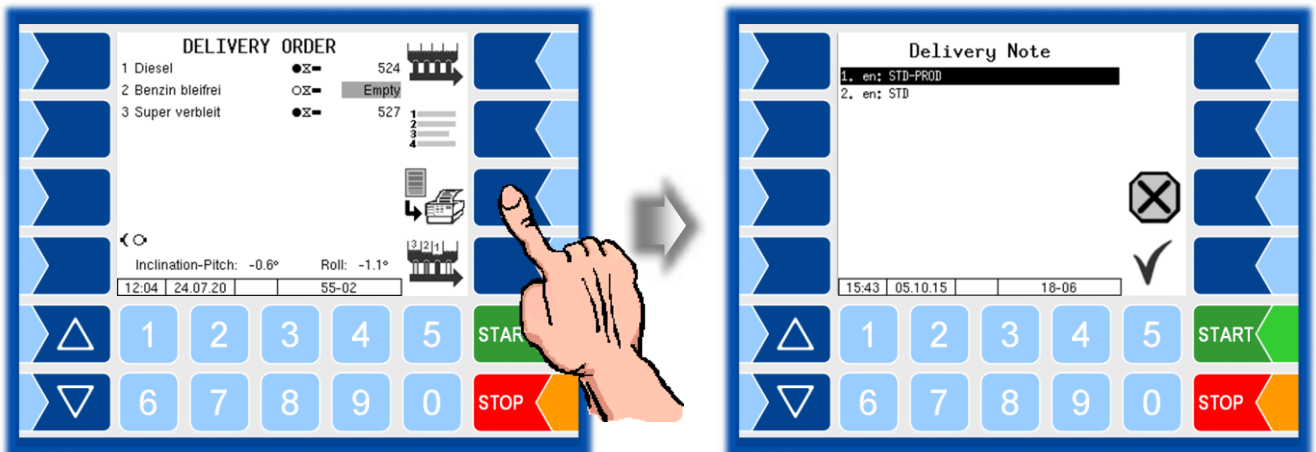

If no printer is configured, the delivery window will close immediately.

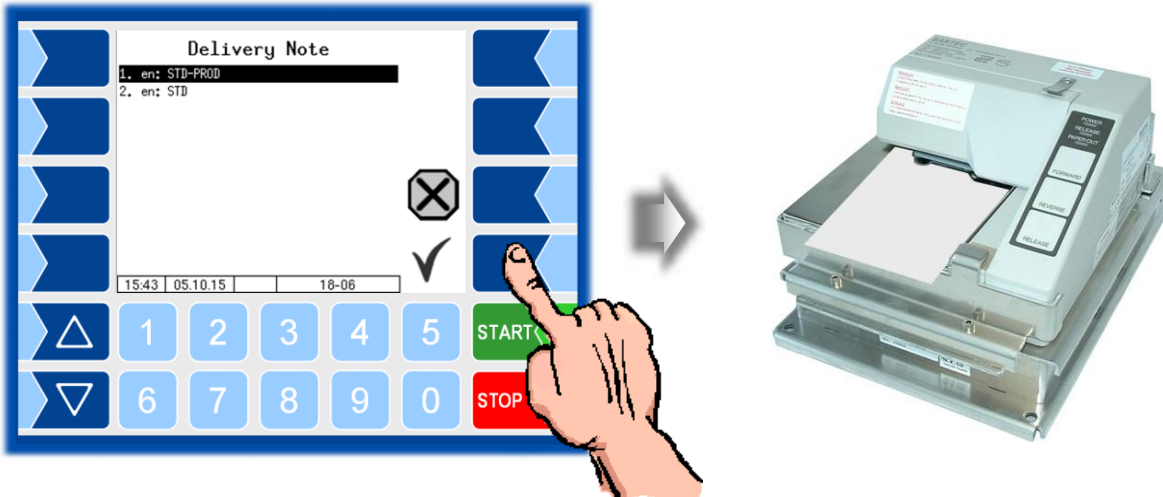

The compartment status is printed in the lines for start delivery or end of delivery.
 If "Summarise products" is enabled, only the abbreviation will be printed.

Status		
Load	L	(No delivery had been started after loading)
Volume	V	(Residual quantity, wet leg sensor still wet)
Rest	R	(Compartment empty, wetleg sensor not wet, but lag time not yet expired)
Empty	E	(Compartment empty)

```

Delivery Note      10015
Order Number ..... 55-002
Customer Number ...
Truck Number ..... 1
Tank Number ..... * 123BA456*
REG-EN 123
Driver Number .... 11
Date of delivery .. 05.10.15
Start Time ..... 16:16
End Time ..... 16:17
Mp./Sequ.: 1/0062
Start Comp. 1 16:16 L
Load sealed
Product ..... 2
Preset Quantity ... 0 1
Diesel
#DK(DK) 837.0kg/m3#
Average Temperature 0.0 Degree C
Start Vol. (16:16) * 0 1 *
Vol. at Del.Temp. * 617 1 *
Volume 15 degree C * 624 1 *
Stop Comp. 1 16:17 E
GGVS ADR KL3 Zif31C Wt30/1202
Mp./Sequ.: 2/0063
Start Comp. 2 16:16 L
Load sealed
Product ..... 3
Preset Quantity ... 0 1
Benzin bleifrei
#BI(BI) 736.0kg/m3#
Average Temperature 0.0 Degree C
Start Vol. (16:16) * 0 1 *
Vol. at Del.Temp. * 501 1 *
Volume 15 degree C * 510 1 *
Stop Comp. 2 16:17 E
GGVS ADR KL3 Zif3B Wt33/1203
Data from verified devices
are enclosed in *asterisks*
    
```

Example Delivery Note



You can print as many copies of the receipt as you need as long as no new order has been started (cf. section 6.4).

4.4 Valve monitoring



The vehicle can optionally be fitted with the SPDS system (Sealed Parcel Delivery System).

This system works by providing an electronic seal for the content of oil tankers and monitoring receipts. This ensures that the product is delivered to the customer in the requested quantity and of the specified quality.

-  After each authorized transaction the compartment is sealed electronically. The compartment remains sealed even during a controlled and planned delivery. After the delivery the compartment is sealed.
 -  In the case of irregularities such as opening a valve configured to seal a chamber (e.g., API), the chamber is unsealed.
- The status of the seal is indicated in the display by the padlock symbol.

Status of the compartment seal

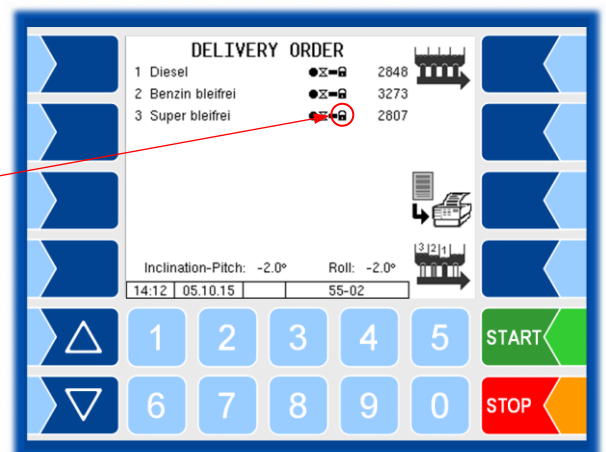

Compartment seal status	
	Compartment sealed
	Compartment not sealed

4.5

Operation with data transfer from OBC



If the data is transferred from the OBC (on-board computer), the basic procedures apply, as described in sections 4.1 to 4.4.

This section explains the differences using some typical operations.

In the case of deliveries over the collector, only parallel deliveries are described here. Serial deliveries are also possible. They differ from the parallel deliveries only in the choice of the delivery type. In this case, the delivery from the selected chambers does not take place simultaneously, but one after the other (see also section 4.3.3.2).

4.5.1

Order data

4.5.1.1

Receiving order data

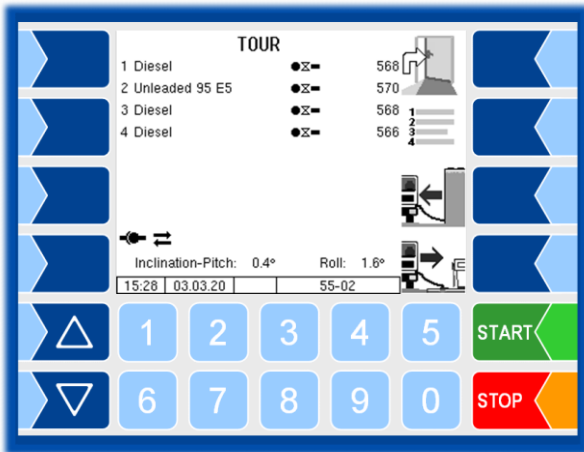

The order data is sent from the OBC to the vehicle. To do this, the driver must initiate data transmission at the OBC. The data for the next order is then transferred.

The current status of data transmission is shown in the display.

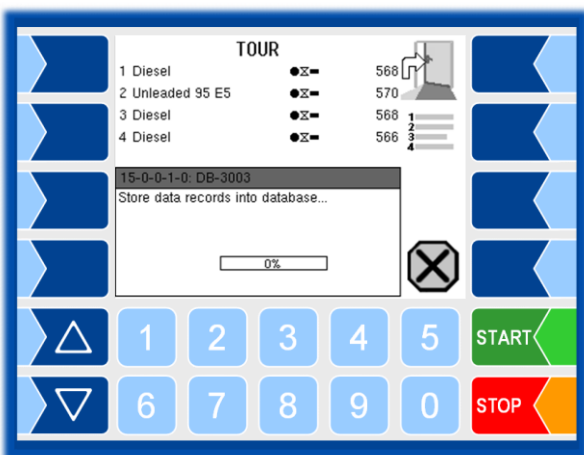

Data transfer has started.

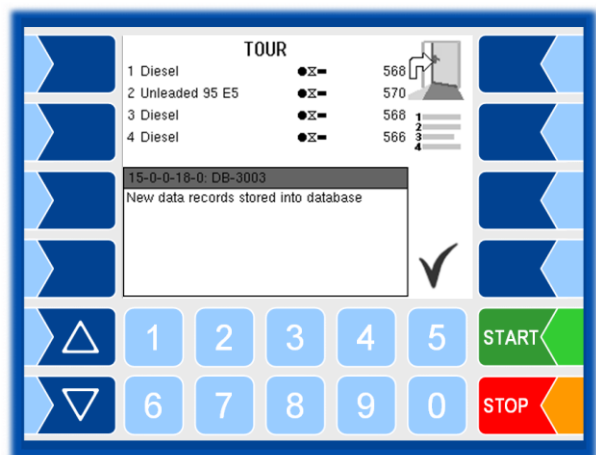



The data was taken.

After the data has been transferred, the order data is displayed.

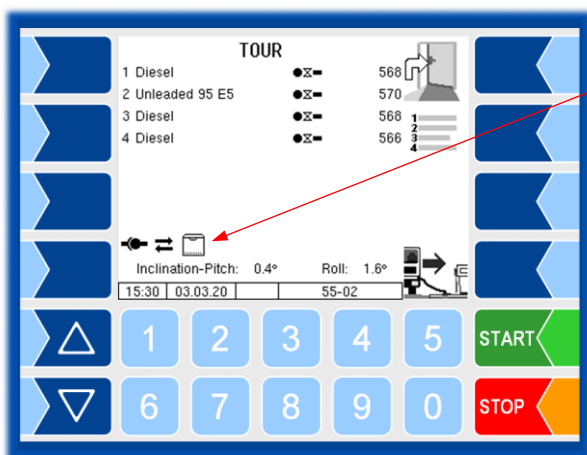
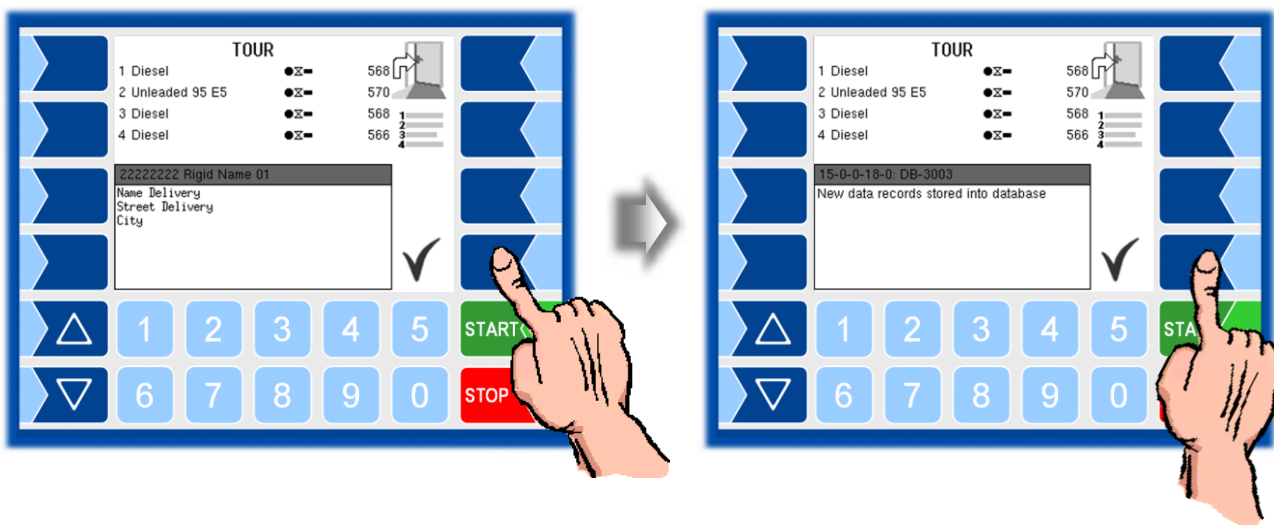
- Confirm the displayed messages.



 After the order data has been accepted, a corresponding symbol is displayed in the tour menu.

 As soon as the order is called up, a tick appears in the symbol.

Depending on the order, only the relevant softkey (loading or delivery) is available to start the order.

4.5.1.2 Order data display

You can use the fourth softkey from the top left of the display to call up the order data display again.

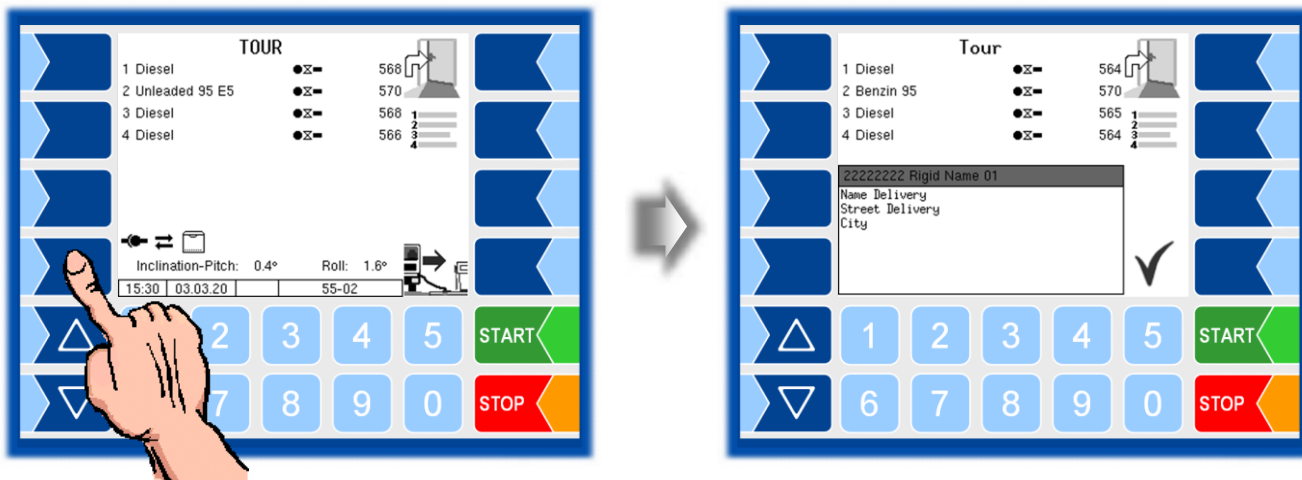

4.5.1.3 Show order items

After the order has started, you can use the fourth softkey from the top left of the display to call up the display of the order items.

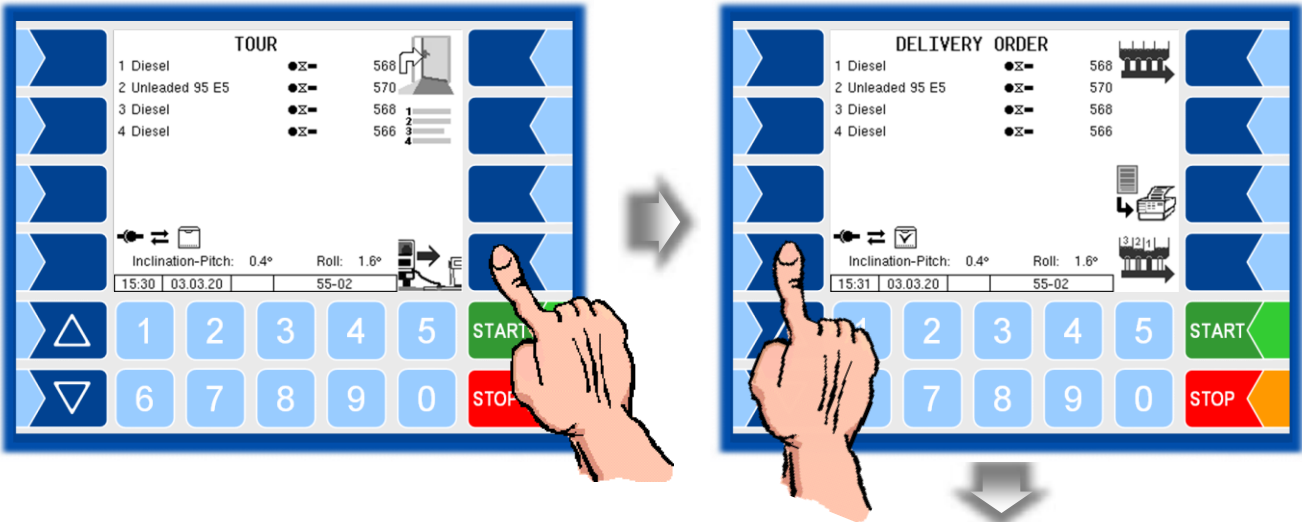

The position of the compartment is symbolized by a hyphen.

Example 2 – 34: Compartment 2 in the trailer
Compartments 3 and 4 in the tank truck.

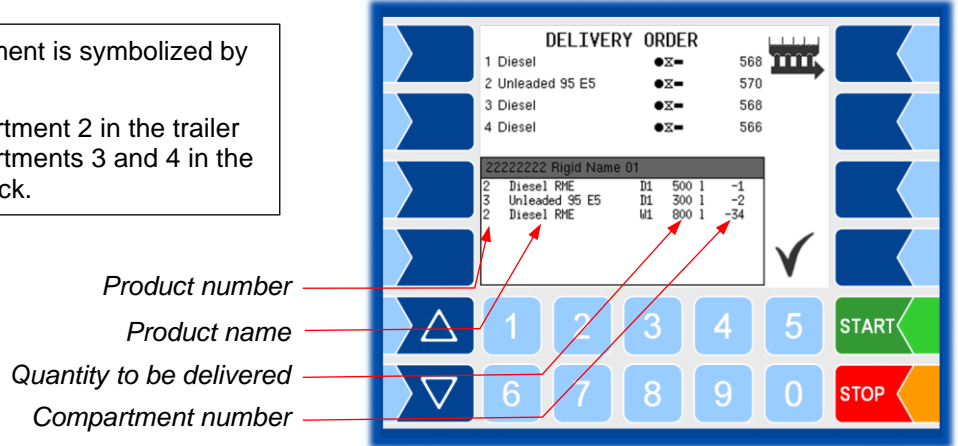

The quantity specified in the order items is adopted as the preset quantity for the delivery.

4.5.1.4 Hose selection

If several hoses on the vehicle are available for an order, but no hose number has been transferred with the order data, the "Hose selection" window is displayed after confirming the order data. Use the arrow or number keys to select the hose to be used.

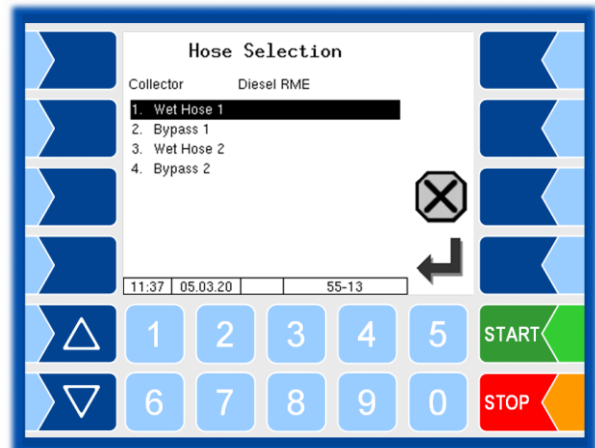

4.5.2 Loading

The basic procedure for loading is described in section 4.2.

After receiving the order data, the loading plan is displayed in accordance with the loading order.

- Confirm this data.

In the following window, only the softkey for starting the loading order is available.

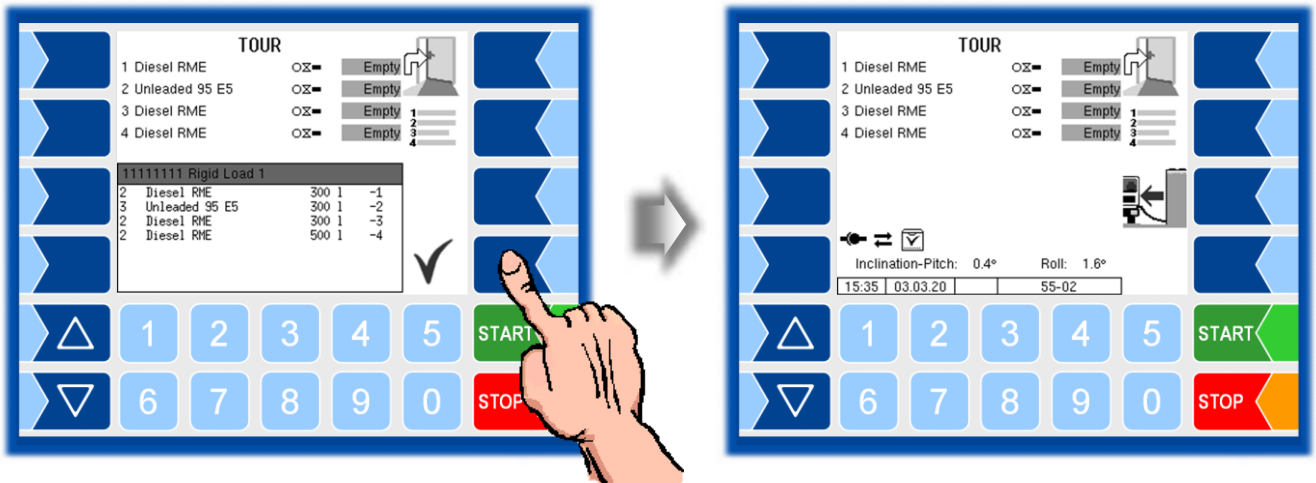

- Touch the "Load" softkey. The loading menu is displayed.

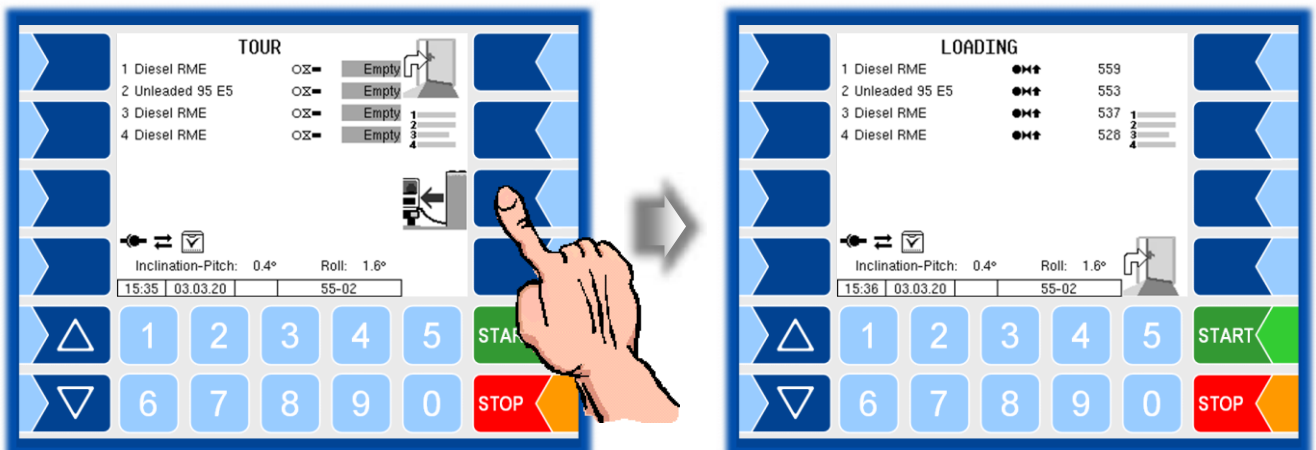

After transferring the preset data, the product names for the compartments to be loaded are adopted. It is not necessary to assign the products via the product mapping.

- Load the compartments with the products provided in the loading plan.



Follow the regulations for loading in accordance with the operating instructions for the vehicle!

4.5.3 Direct outlet delivery

After receiving the order data, only the softkey for the delivery order is available.

- Start the order.

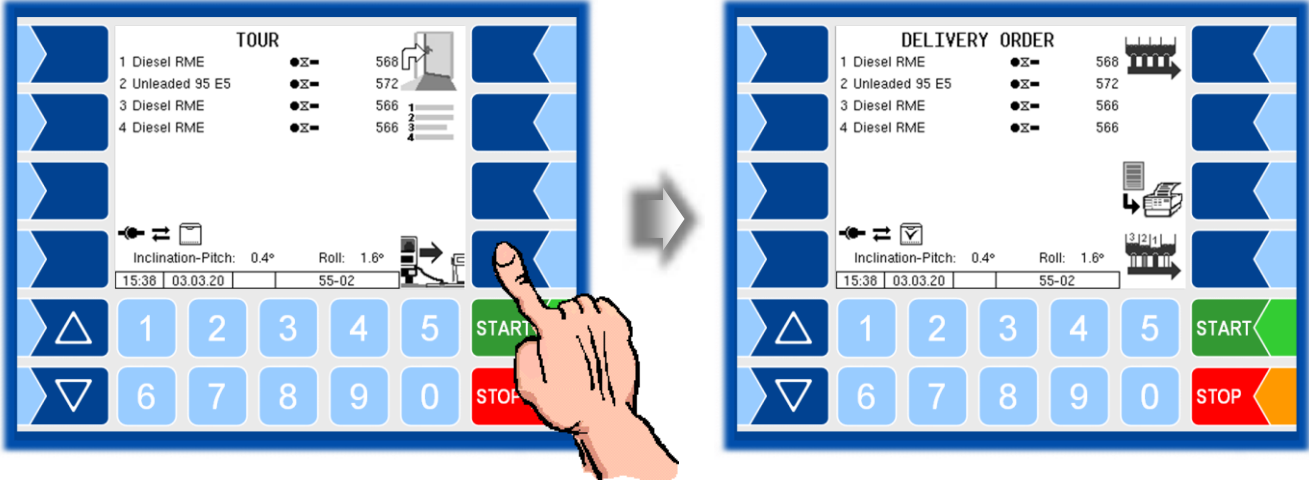

- Select one of the compartments according to the order content. All order items with this compartment are displayed.

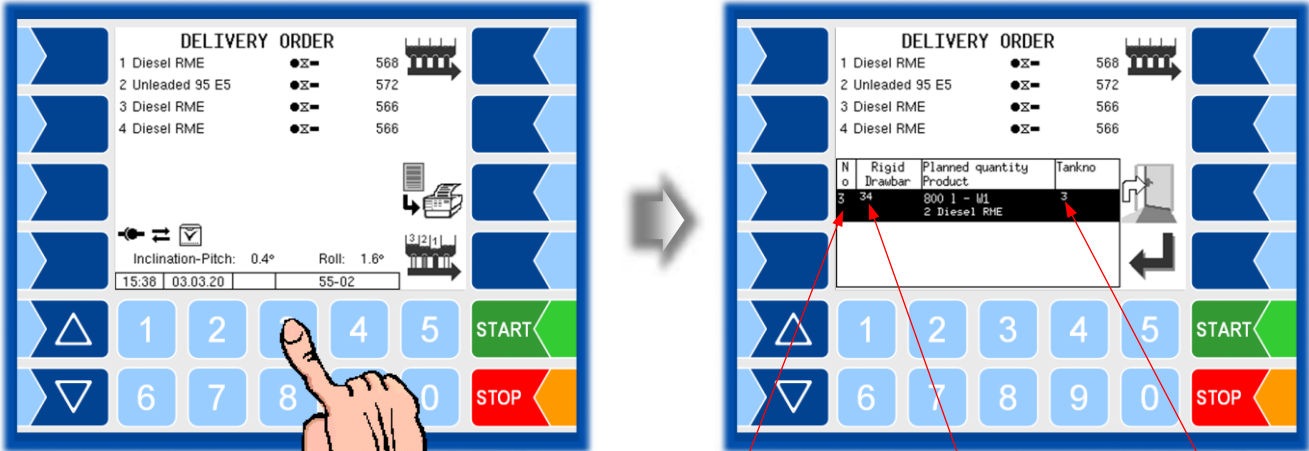

Compartment selection

Number of the order item

The compartment numbers of the towing vehicle are shown in the top line.

No. of the destination tank

- Confirm the selected item and release the delivery for the selected compartment.

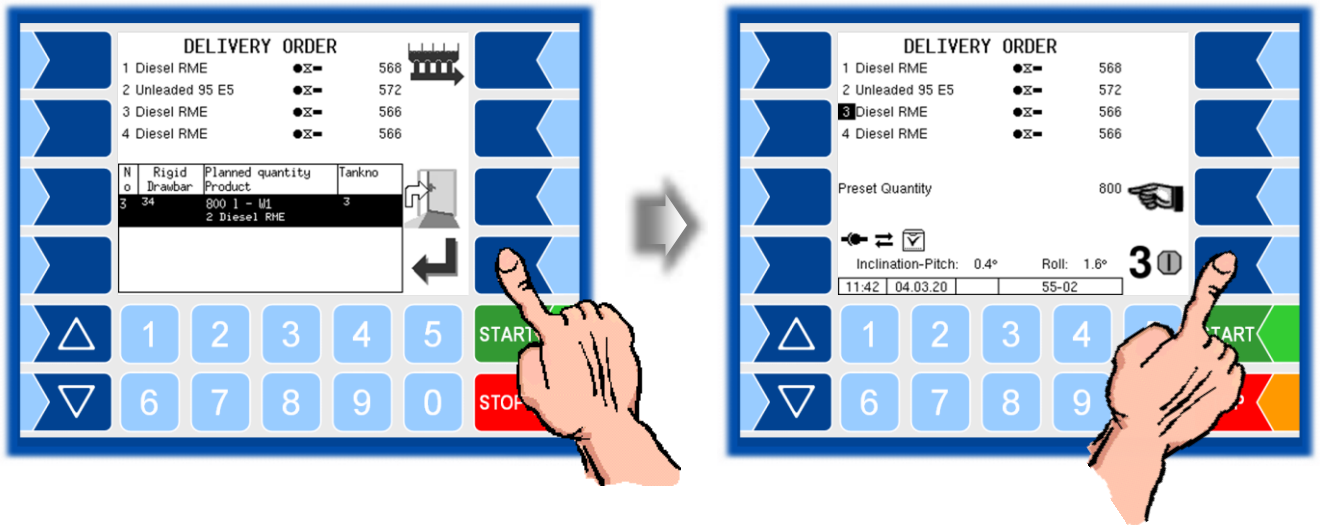

The further procedure and the use of available options correspond to the description in section 4.3.2.

4.5.4 Delivery via collector 'Wet hose parallel'

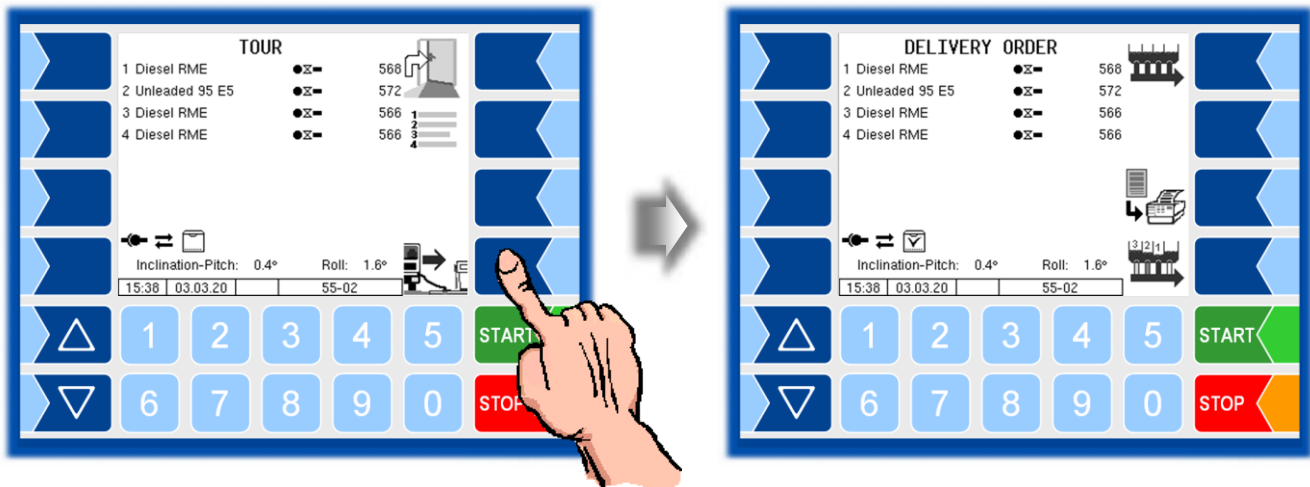

- Touch the "Simultaneous delivery" softkey.
The order items with compartment and product numbers, specified quantities and the delivery hose designation are displayed.
- Use the arrow keys to select an item. Confirm the selection.

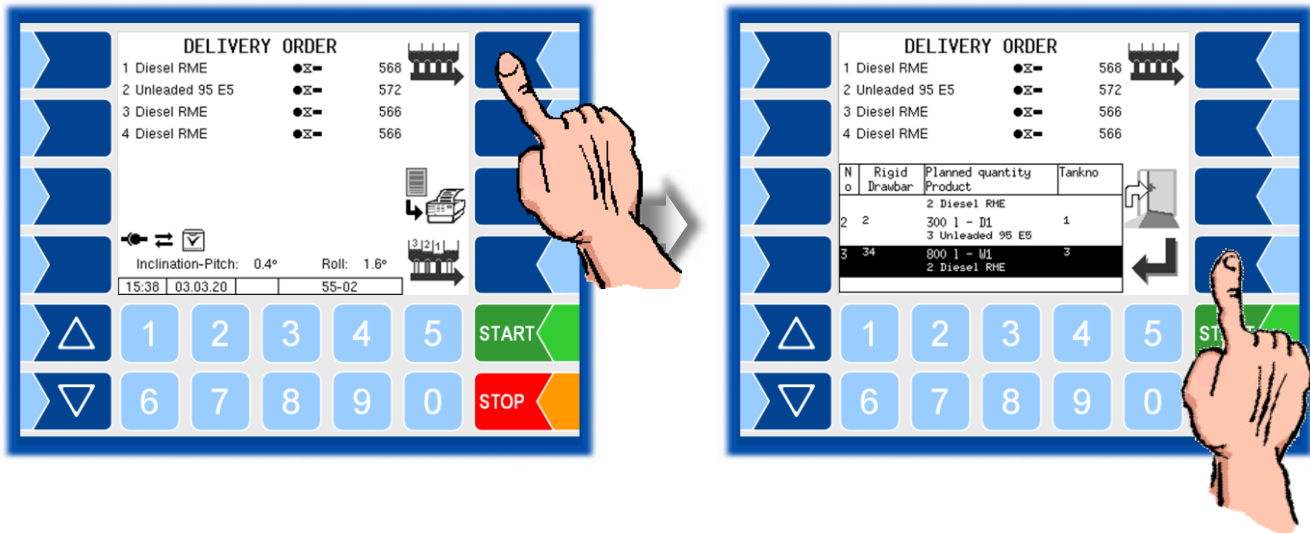

- Then enter the numbers of the compartments from which the delivery should take place.

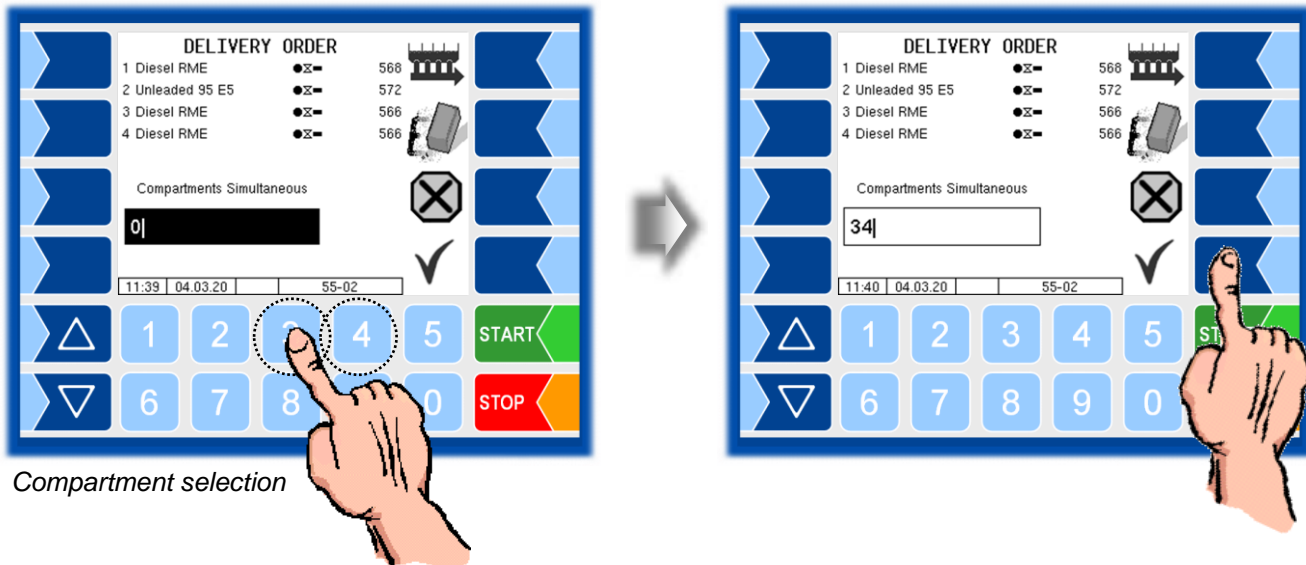

Removing residues from the collector

 If a preset quantity has been transferred with the order data, the „Removal of residues“ softkey is displayed. Touch this softkey if the collector should be emptied at the end of the delivery. Otherwise the collector remains filled with the product. In this case, you can only trigger the removal of residues from the collector in the additional menu (see section 6.11).

 If you have activated residue removal, you can use this softkey to deactivate it as long as you have not yet started the process.

The further procedure corresponds to the description in the section 4.3.3.1.

4.5.5 Delivery via collector from the trailer 'Wet hose parallel'

After starting the delivery order, the compartments of the truck are shown on the display.

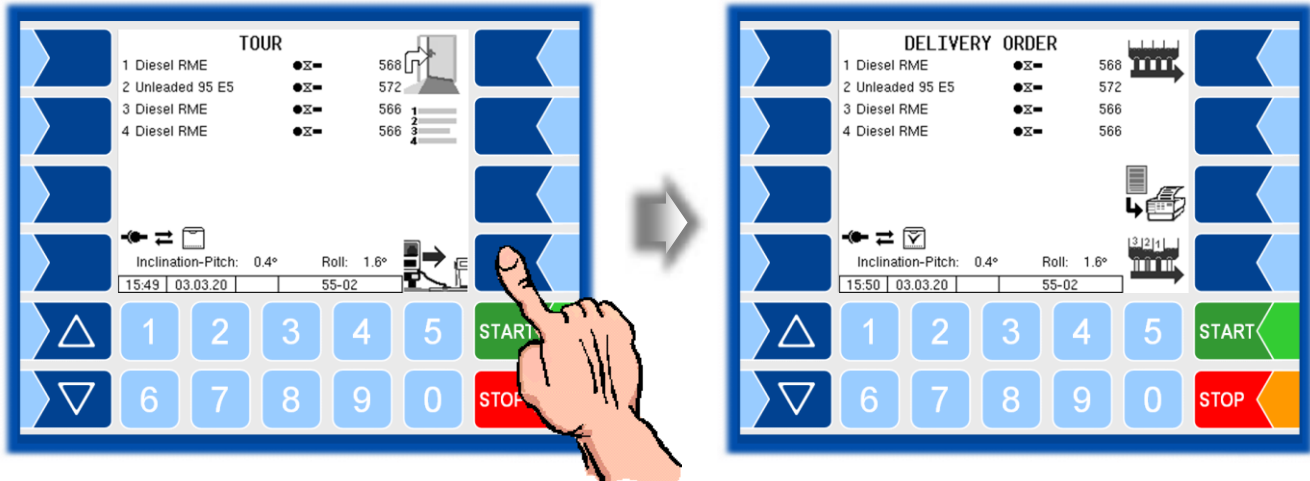

- Use the selection button  to switch to the display of the compartments of the trailer.

With the  button you can switch back to the display of the compartments of the truck.



The compartments of the trailer are marked with a < .

Compartments in the truck

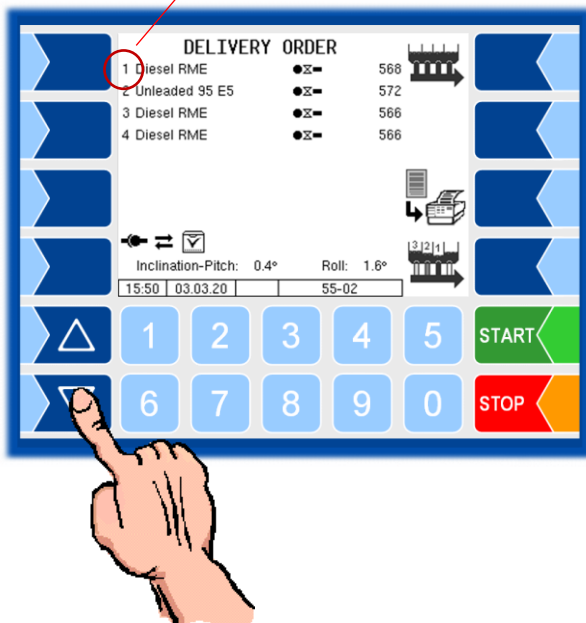

Compartments in the trailer

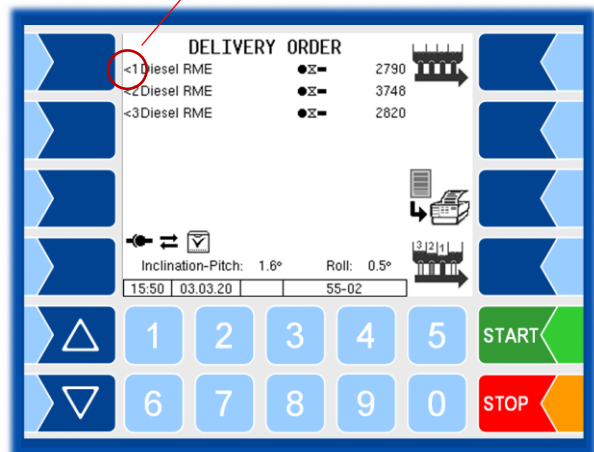

- Touch the "Simultaneous delivery" softkey".
The order items with compartment and product numbers, specified quantities and the delivery hose designation are displayed.

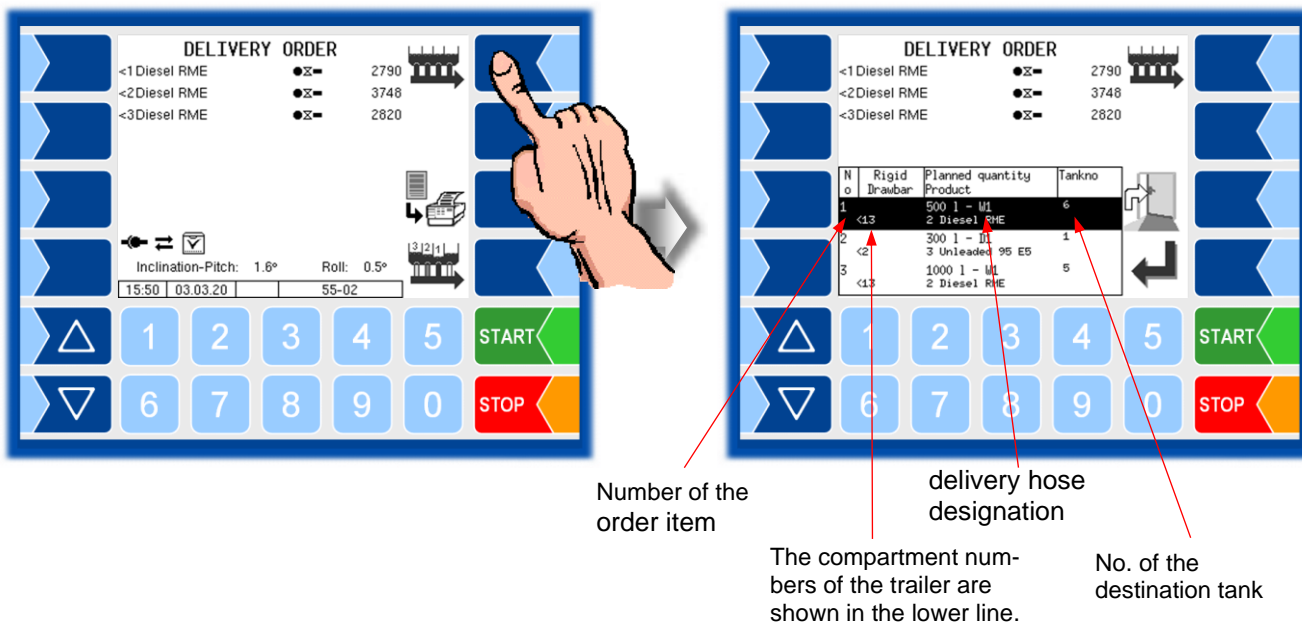

- Use the arrow keys to select a position. Confirm the selection.
- After confirming the order item, enter the numbers of the compartments from which the delivery should take place. Confirm the compartment numbers for the product delivery.

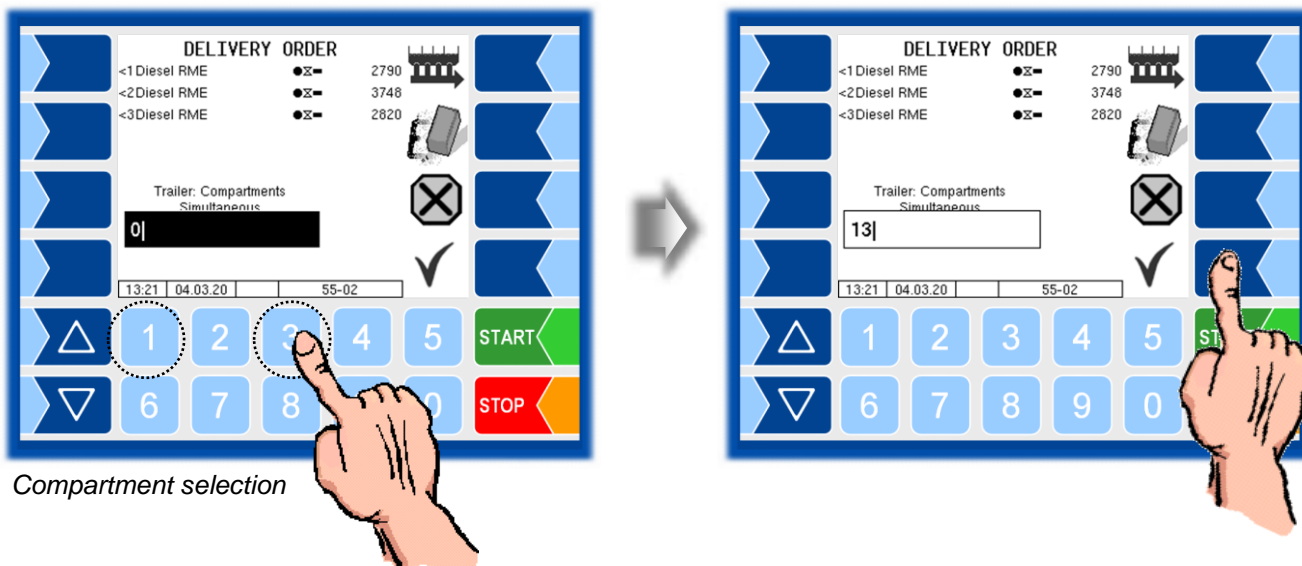

Compartment selection

The notice on page 59 applies to removing residuals from the collector after delivery.

- With the "Start delivery" softkey, the delivery is enabled for the selected compartments.

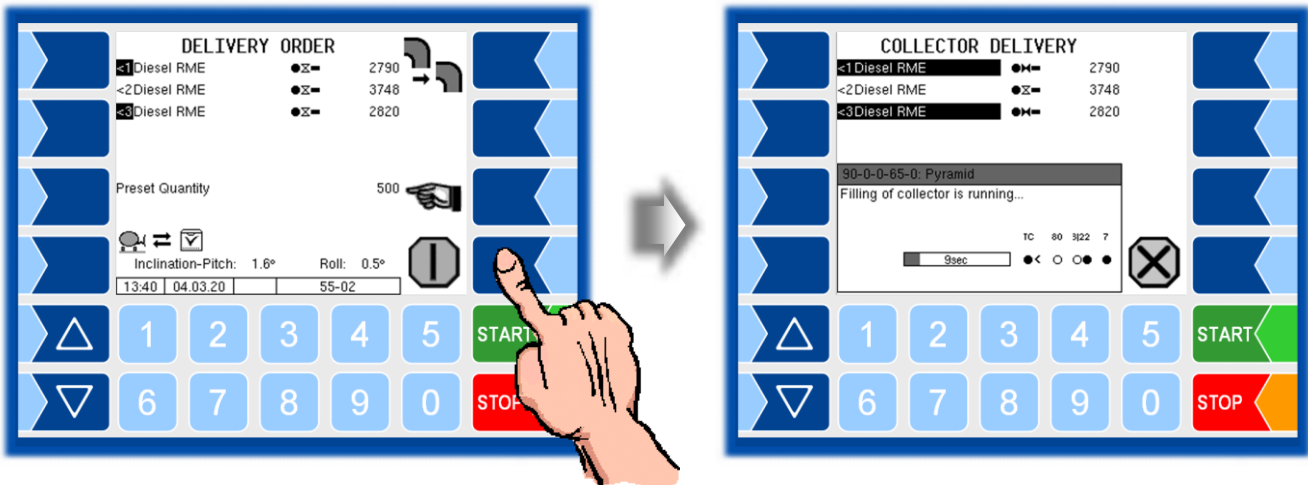

The further procedure corresponds to the description in the section 4.3.3.1.

4.5.6 Pumping over from the trailer

If products from the trailer are to be pumped into the towing vehicle, this can also be done by specifying an order.

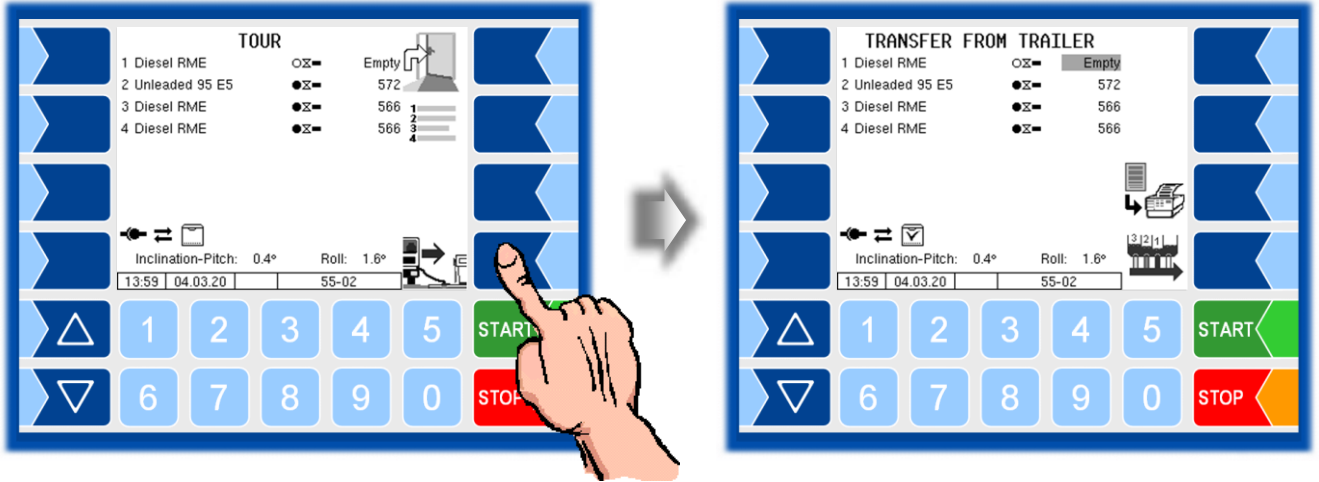

- Touch the collector delivery softkey. The data for the pumping process (source and destination compartment, quantity, product name) is displayed.

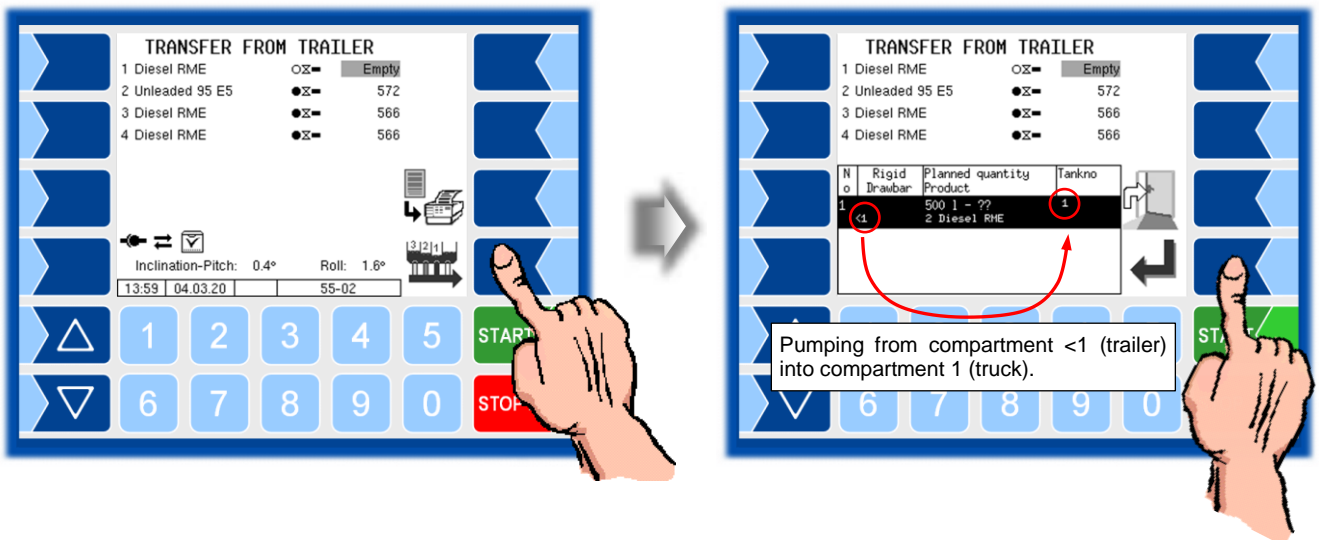

- Start pumping over with the "Start delivery" softkey“.

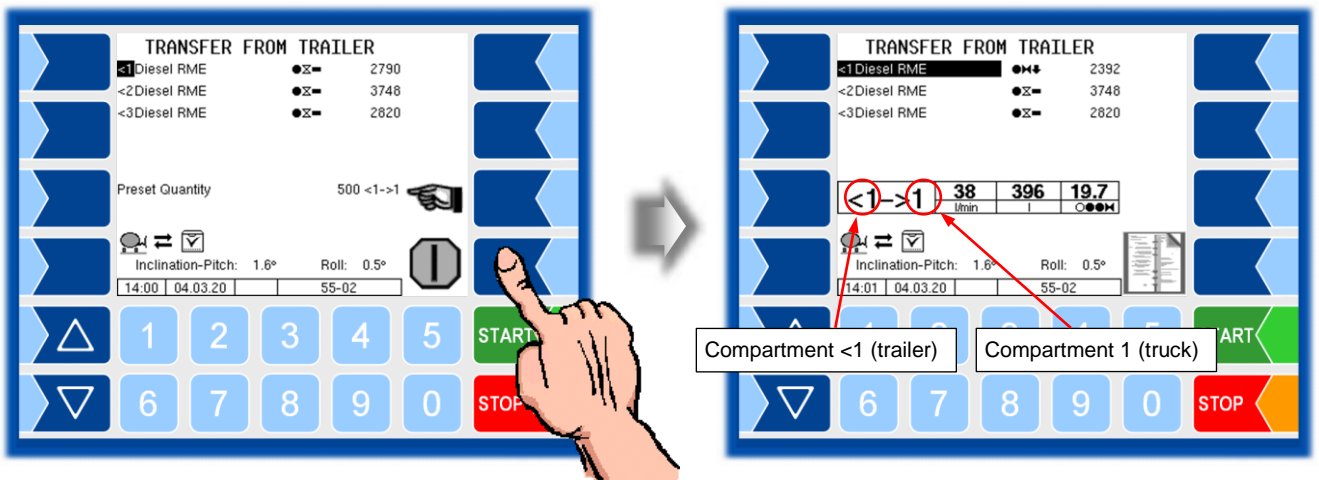

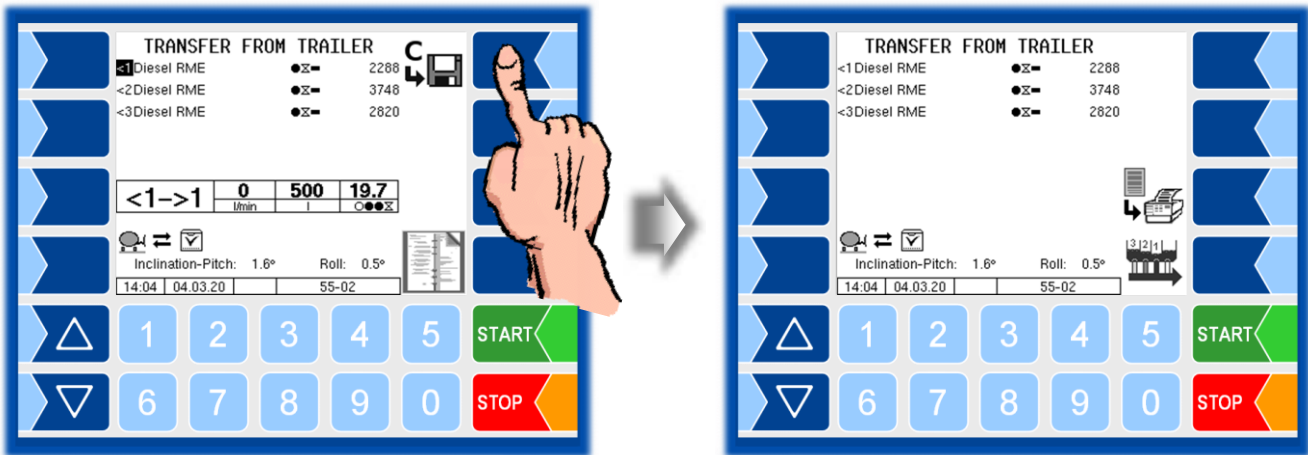

If the specified quantity has been pumped over, the process stops.

- Save the data of the pumping process.

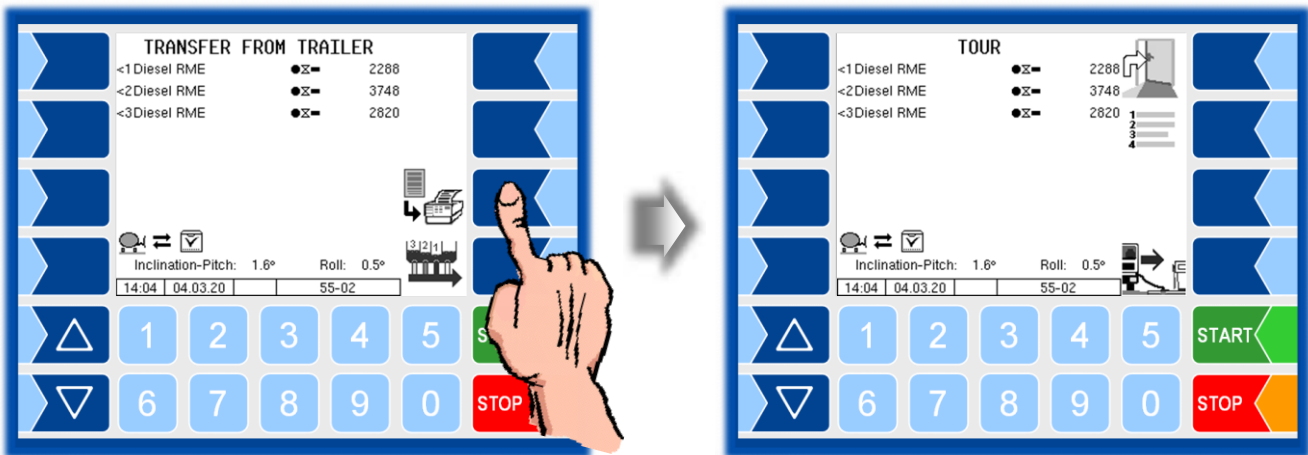

- Finish the order.



With the  button you can switch back to the display of the compartments of the truck.

4.5.7 Flushing the wet hose

If there is a product change for an upcoming order, it is necessary to flush the hose. A corresponding flushing order can be done for this.

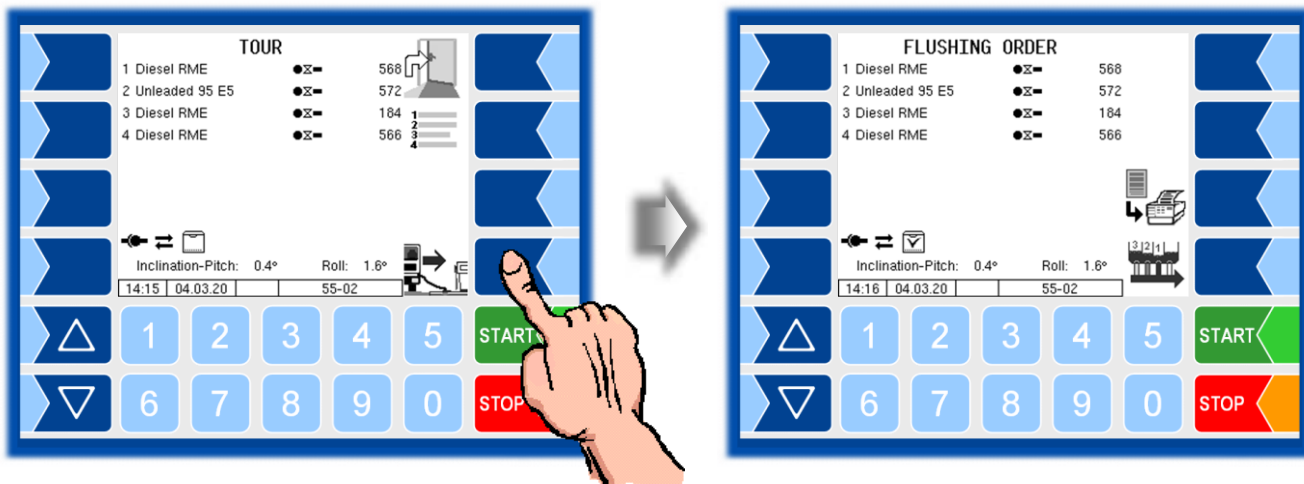

- Touch the collector delivery softkey. The data for the pumping process (source and destination compartment, quantity, product name) is displayed.

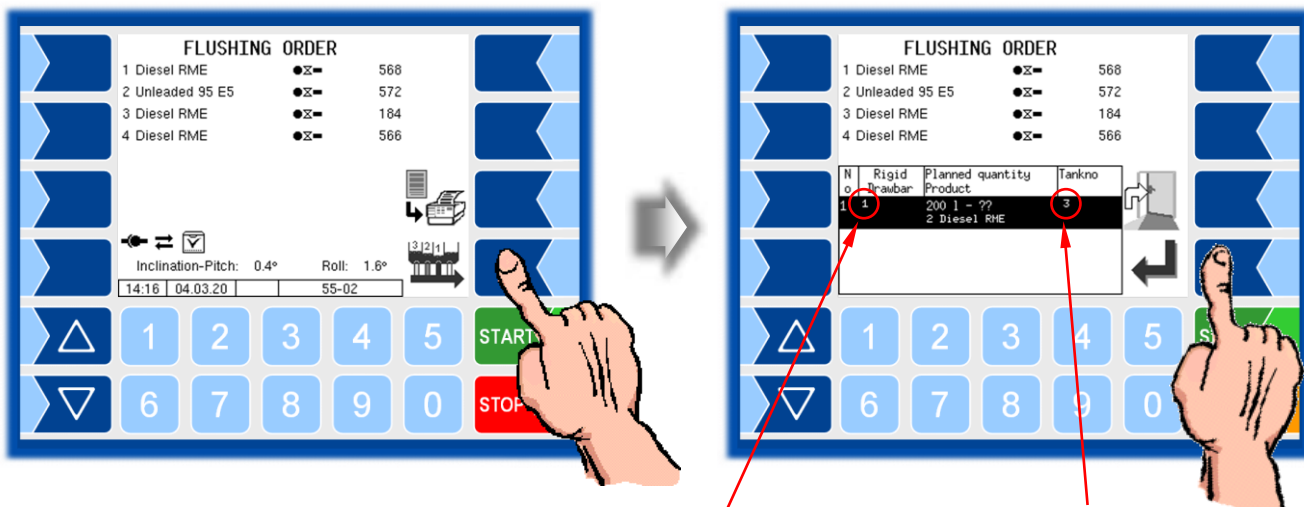

Example The hose is flushed with 200 l of diesel from compartment ①. The flushing product shall be pumped into compartment ③.

Make the connection of the hose to be flushed to the specified destination tank.



Follow the instructions given by your company for flushing regarding the selection of the target tank for the flushing product.



Removing residues from the collector

If a preset quantity has been transferred with the order data, the „Removal of residues“ softkey is displayed.

Touch this softkey if the collector should be emptied at the end of the delivery. Otherwise the collector remains filled with the product.

In this case, you can only trigger the removal of residues from the collector in the additional menu (see section 6.11).



If you have activated residue removal, you can use this softkey to deactivate it as long as you have not yet started the process.

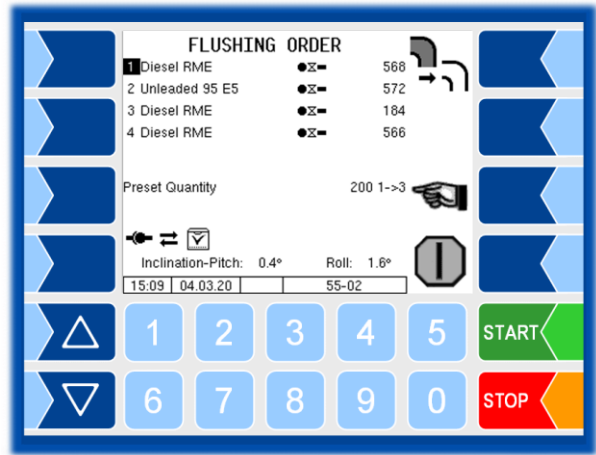
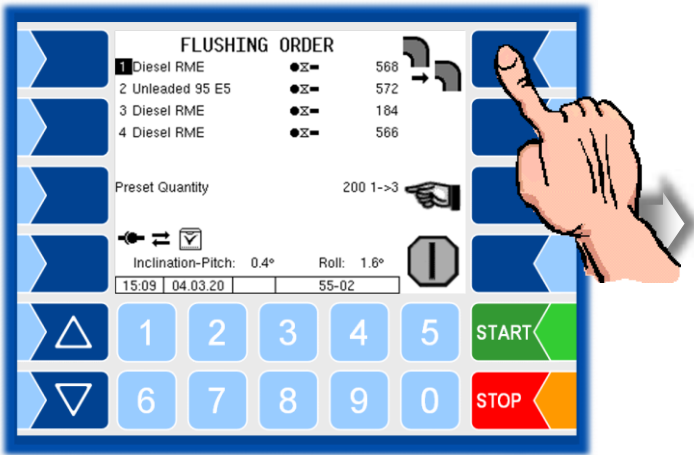

- Start the flushing with the "Start delivery" softkey.

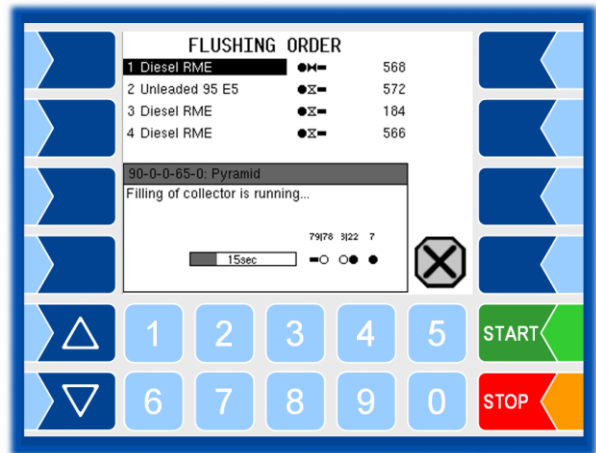
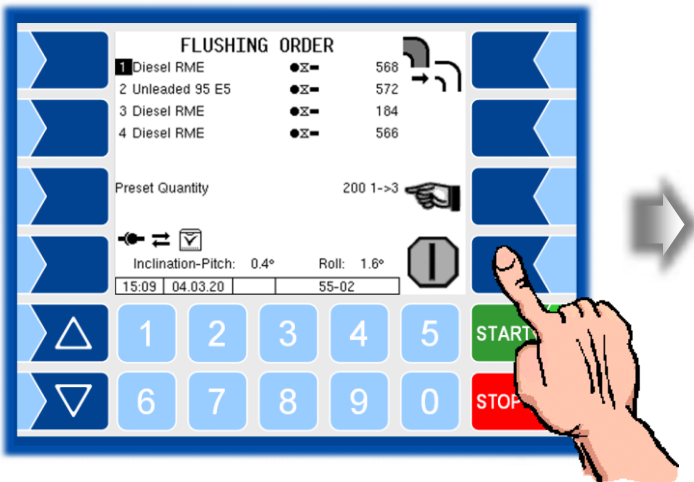

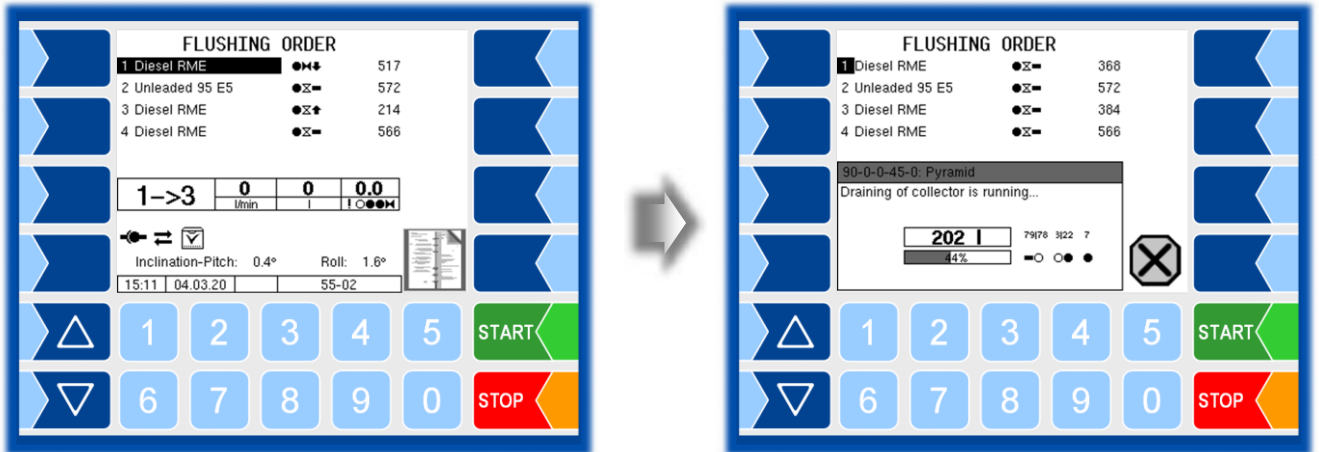

- Save the data of the flushing order at the end of the process and end the flushing order.

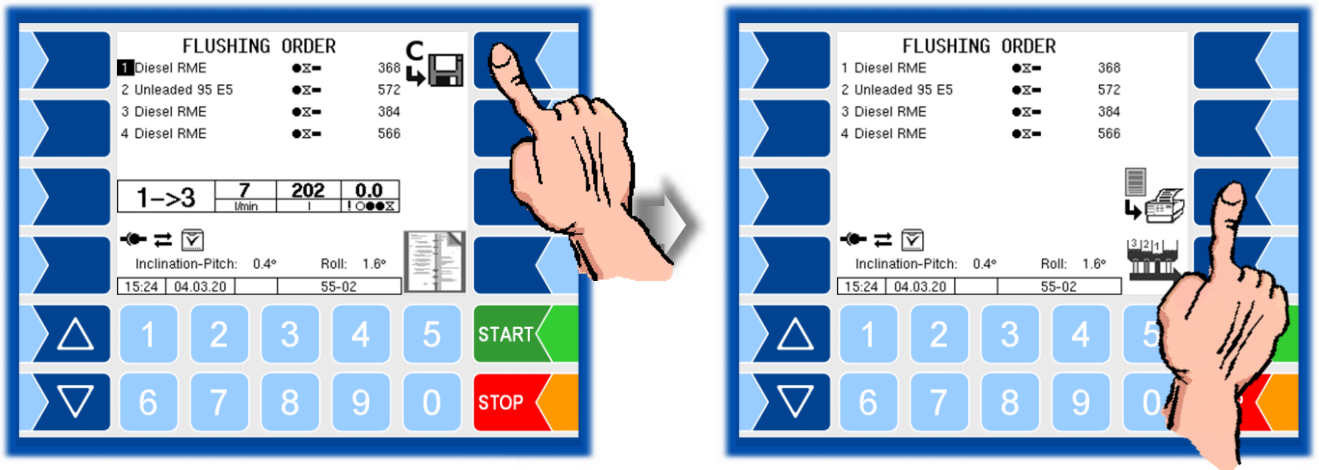

5 Administration menu

The third softkey down, to the left of the display, is used to open the Administration menu.

The Administration menu contains submenus. Most of the menus in the configuration and in the service menu are write-protected by passwords. The submenus of the "Configuration" menu, you can open without entering a password, but not make any changes.



Only the menus and functions are described here, to which you have access without entering a password or after entering the driver password.

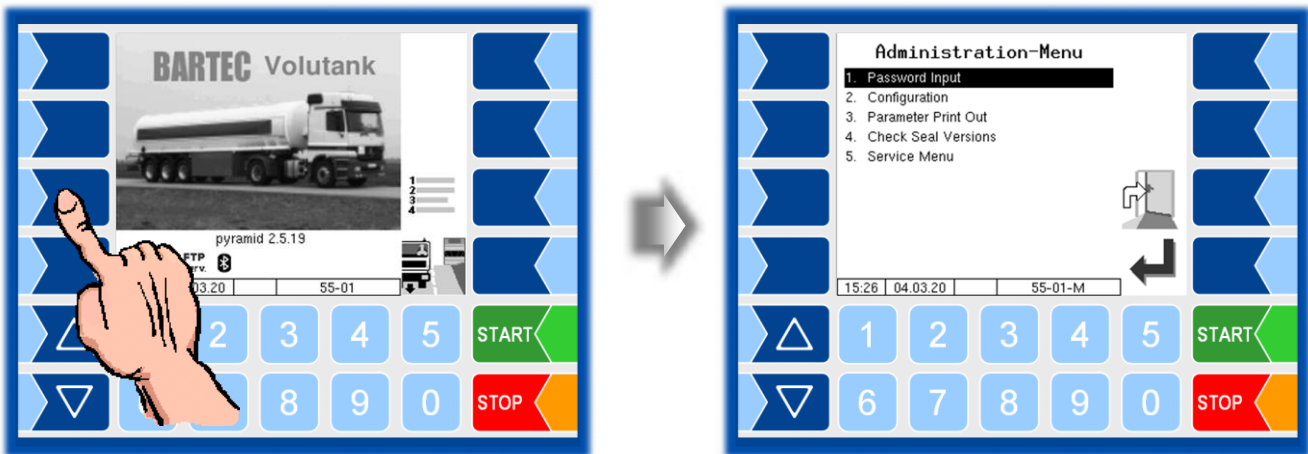

5.1 Entering the driver password

The driver password is the sum of the day, month and hour (as shown on the display).

Driver password = day + month + hour

Example

Date: 21. 03. 2020, 07:28 h

Driver password = 21 + 3 + 7 = 31

- Confirm the „Password Input“ item from the Administration menu.

You can enter the password in the following window.

Numerical entries are entered using the keys below the display.

If you need to make any corrections, you can use the softkey with the rubber symbol. When you touch this softkey, the character to the left of the cursor is deleted.

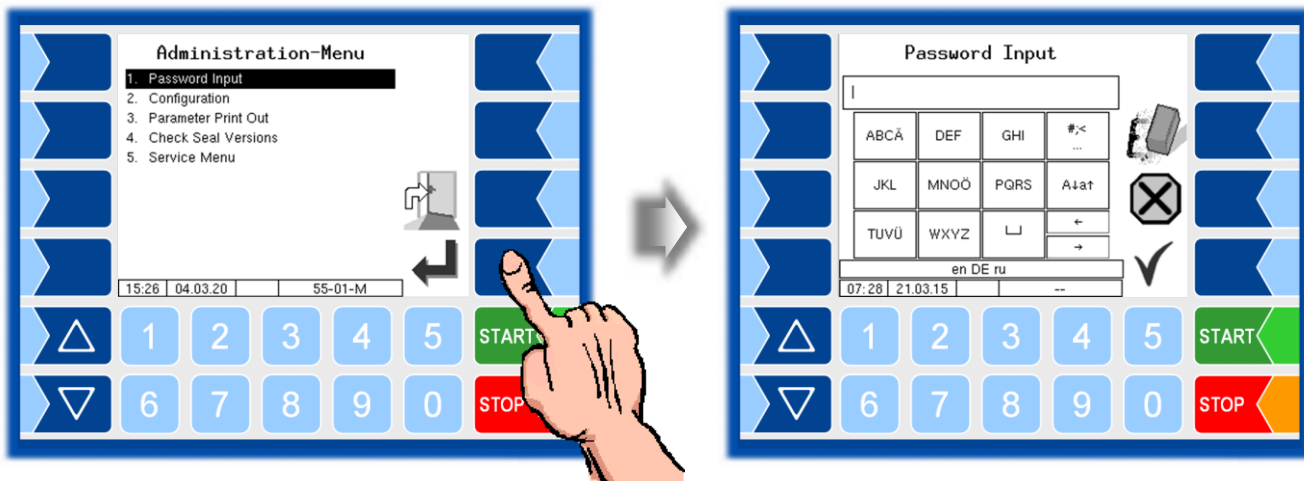

- Once you have entered the full password, touch the “Confirm” softkey“.

The system then shows the password level that you can access (D).

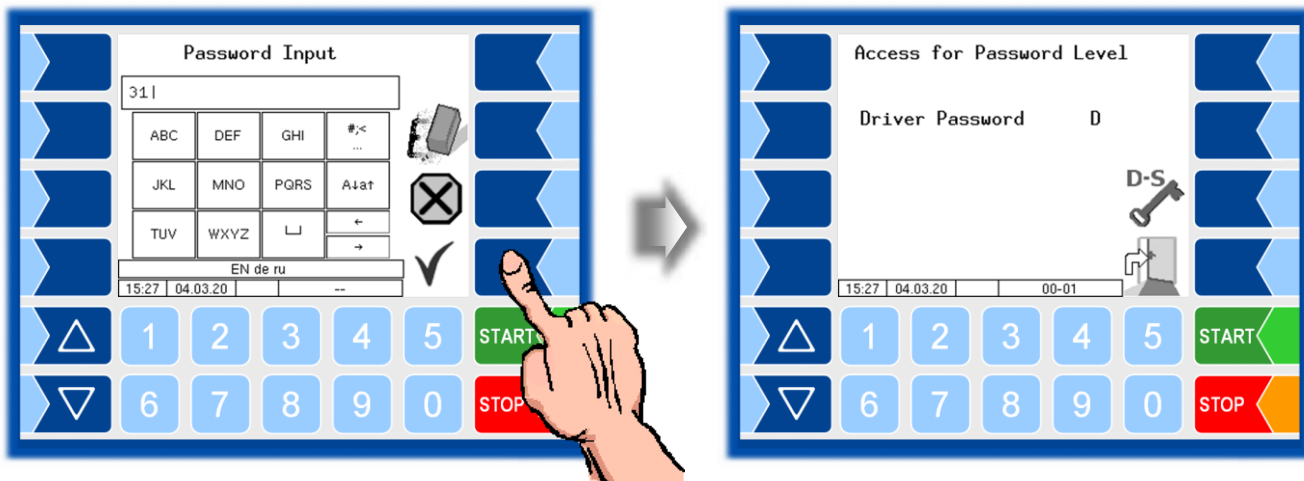

The softkey  opens the window for entering the password (Driver-, User- or Service-Password) again.

- Touch the  softkey to return to the menu selection.

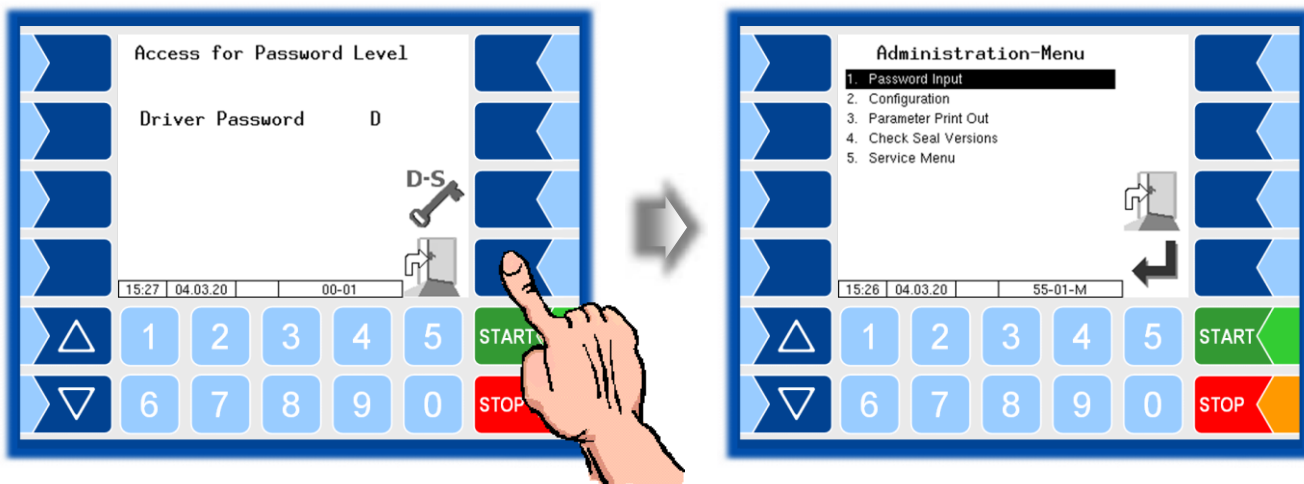

5.2 Parameter Print Out

- Select the “Parameter Print Out” menu from the administration menu.

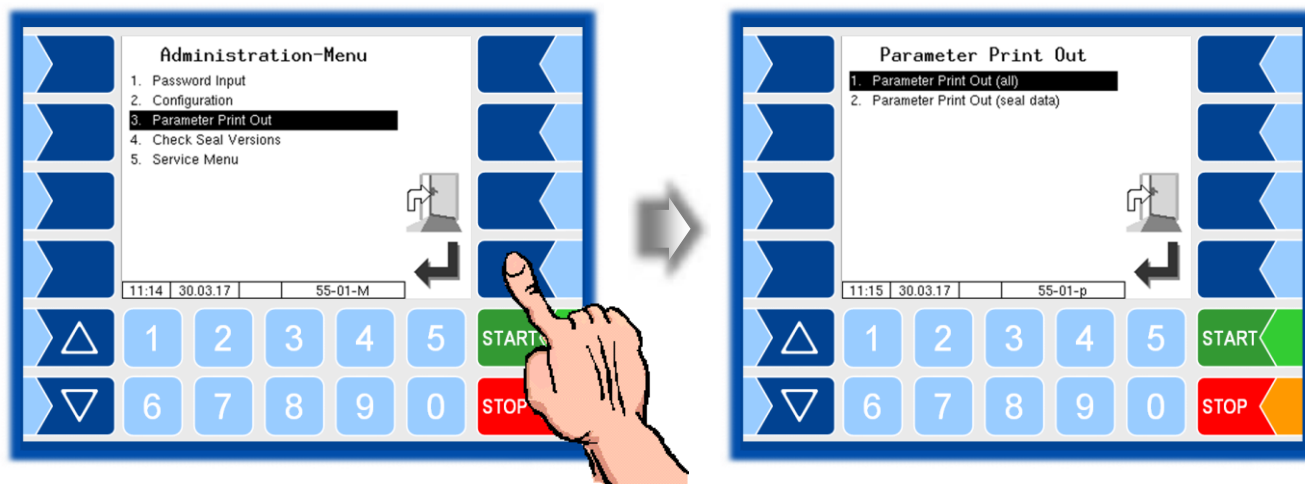

- Select whether to print the parameters completely or only the calibration relevant data.

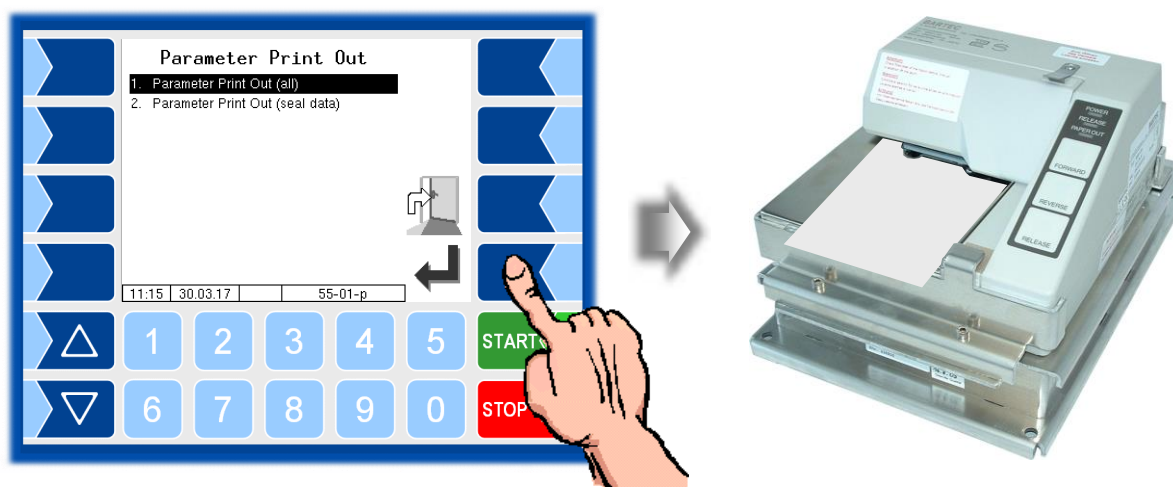

The current settings for the configuration parameters are output to the configured printer.

Meaning of the abbreviations for the product configuration on the parameter print	
P	Product number
U	Unit
Cal	Calibration factor
D	Density
BT	Basic temperature
CMo	Compensation mode
CFac	Compensation factor
C	Product compensated
Pg	Product group
Short	Shortcut
SW-L	Floater depth
Product	Product name
mP	Allocation for metrological product
addM	Additive mixing ratio
Price	Price
T	Tax
aP	Additional product
L:P	Load PID
I	Discharge PID leaded
D:P	Discharge PID
I	PID- Discharge leaded
Lm	Load magnet
Dm	Discharge magnet
Oil	Oil company
bundle	Packaging content
Pc	Price code
Pfac	Price factor
Y	Yes
N	No

- 1 : Heating oil/diesel/gasoline
- 2 : Lubricating oils
- 3 : liquid gas
- 4 : linear
- 5 : GTL

```

PARAMETER PRINT 3003 30.04.2020 10:08
=====
Module Signatures
=====
pyramid 2.5.19 2020-03-13 11:55
AN:19112046 APP:1 KERNEL:2.4.25-1.12-V8
Boot Loader:1.13
m-srt      1.1.0   517d03 1.1.0   =
m-dipstick 1.8.0   2303de 1.8.0   =
m-tmup     1.1.0   a221e9 1.1.0   =
lib3003db  1.1.0   aab9e7 1.1.0   =
m-hmi     1.4.0   6cb819 1.4.0   =
emfx      1.0.14  37d2c2 1.0.14  =
umg       1.2.0   21932d 1.2.0   =
m-print    1.5.0   9985a2 1.5.0   =
=====
Time Settings
=====
* System Date       :          09.03.2020
=====
Program Parameter
=====
* Tank Number      :          123BA456
* Netherlands     :          yes
=====
Metrological products
=====
P  U  Cal  D  BT  CMo  CFac  C  Pg  Short
-----
* 1  1  0  837.0 15  1  0.000  Y  1  HEL
* 2  1  1  837.0 15  1  0.000  Y  2  DK
* 3  1  1  736.0 15  1  0.000  Y  3  BI
* 4  1  1  750.0 15  1  0.000  Y  3  SUV
* 5  1  1  748.0 15  1  0.000  Y  3  SU
=====
30.04.2020 10:08
Veh. No.       :    123
Veh. Reg.     :  REG-EN 123
Page 6 of 8 Pages
* 6  1  1  751.0 15  1  0.000  Y  3  SUP
* 7  1  1  797.0 15  1  0.000  Y  2  SDK
* 8  1  1  801.0 15  1  0.000  N  2  J1
=====
P  Product
-----
* 1  Heiz"1
* 2  Diesel
* 3  Benzin bleifrei
* 4  Super verbleit
* 5  Super bleifrei
* 6  Super plus
* 7  Superdiesel
* 8  Jet Fuel A1
=====
Measured products
=====
P  Short  mP  addM  Price  T  aP  L:P  I  D:P  I
-----
1  HEL  1  0  0.00  1  0  69  N  69  N
2  DK  2  0  0.00  1  0  68  N  68  N
=====
30.04.2020 10:08
Veh. No.       :    123
Veh. Reg.     :  REG-EN 123
Page 8 of 8 Pages
    
```

Example parameter printout

5.3 Service Menu

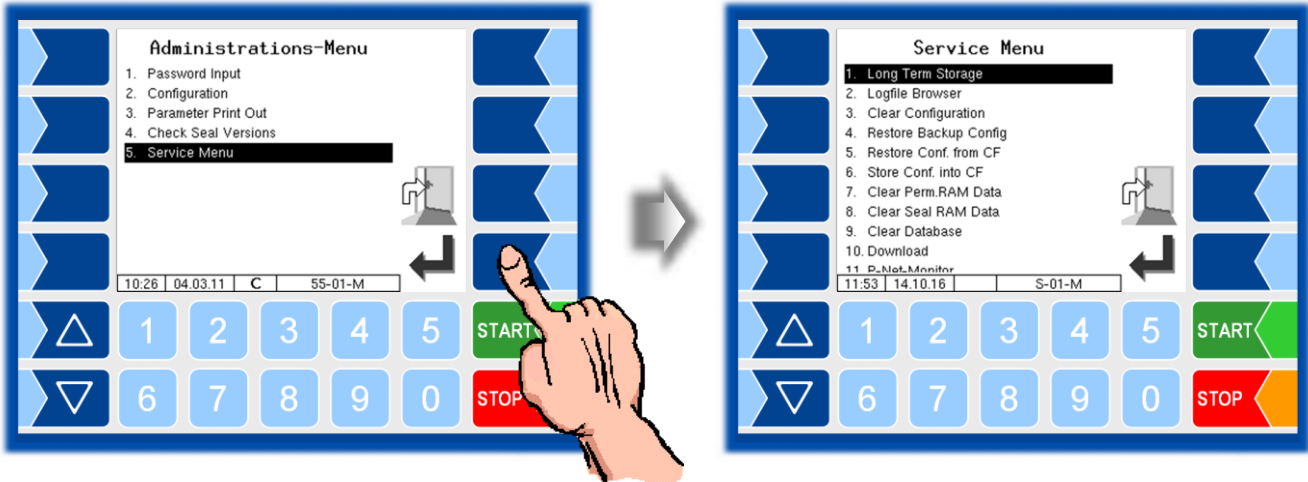

The functions in the service menu can be accessed using the service password. Parameters that are subject to calibration are protected by the seal switch.

The long term storage and the logfile browser can be opened without entering the password.

5.3.1 Long Term Storage (3 months storage)

Long Term Storage stores the tour data for three months. Within this time, you can view or print duplicates of the documents.

You can open the *Long term storage* also in the *Additional functions menu*. How to use this feature is described there (see section 6.3).

5.3.2 Logfile Browser

The logfile browser allows you to view all saved log entries.

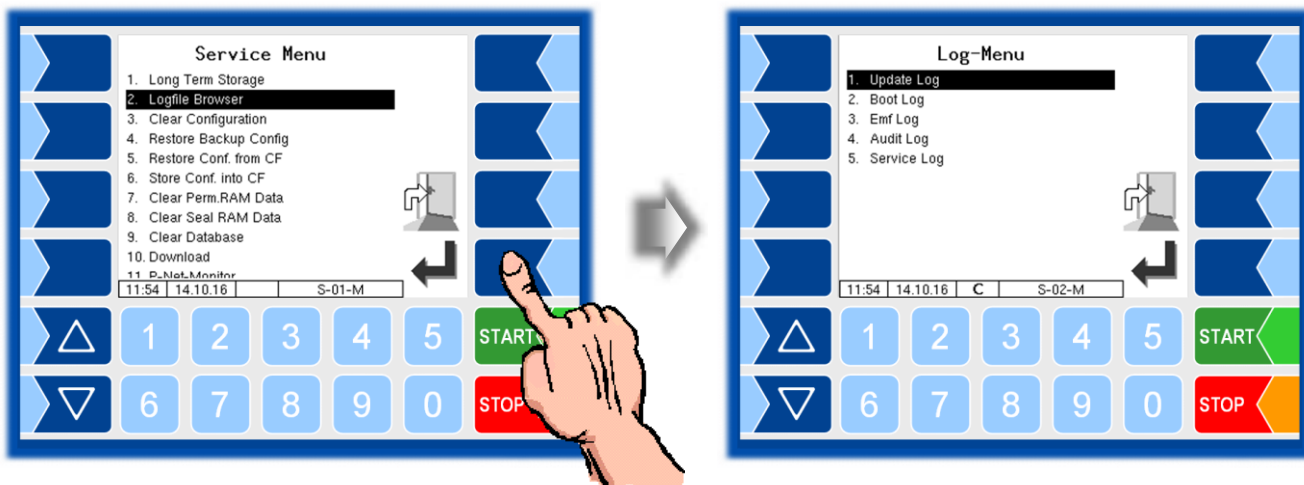

Update Log: Log entries about updates and update attempts
 Boot Log: Boot messages, boot scripts
 Emf Log: Log output from the various applications
 Audit Log: Log entries about all parameter changes
 Service Log: Log entries for service and diagnostics

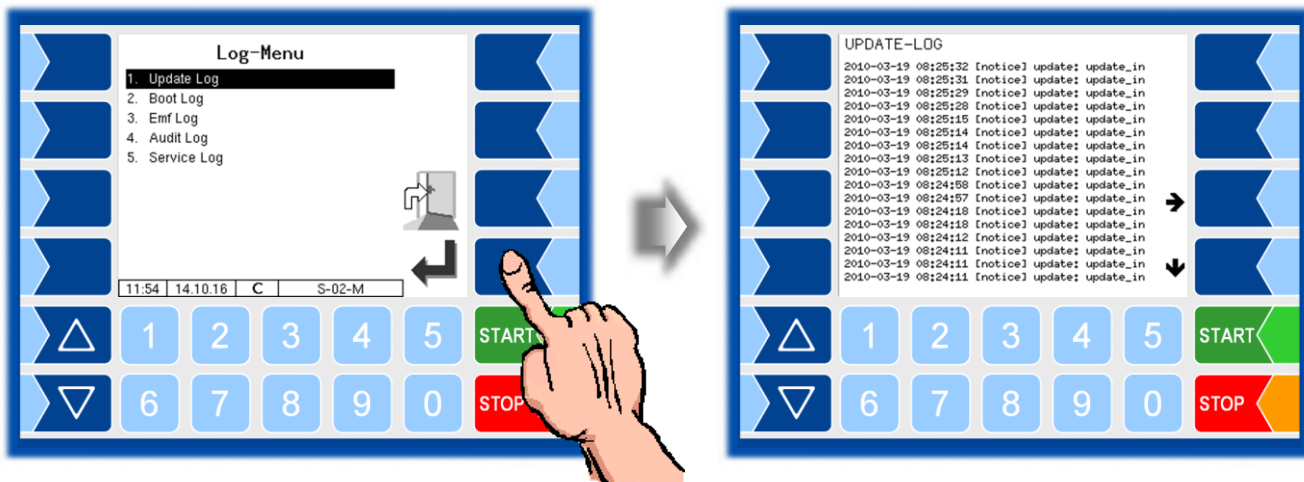

Within the log window, you can move the displayed content to the left, right, up or down using the arrow softkeys.
 You close the log window with the **STOP** key.

6 Additional Functions Menu (within a tour)

You can call up additional functions inside and outside a tour using the additional menu.

The number of available menu functions depends on the configuration. For example, all printing functions are omitted if no printer is configured.

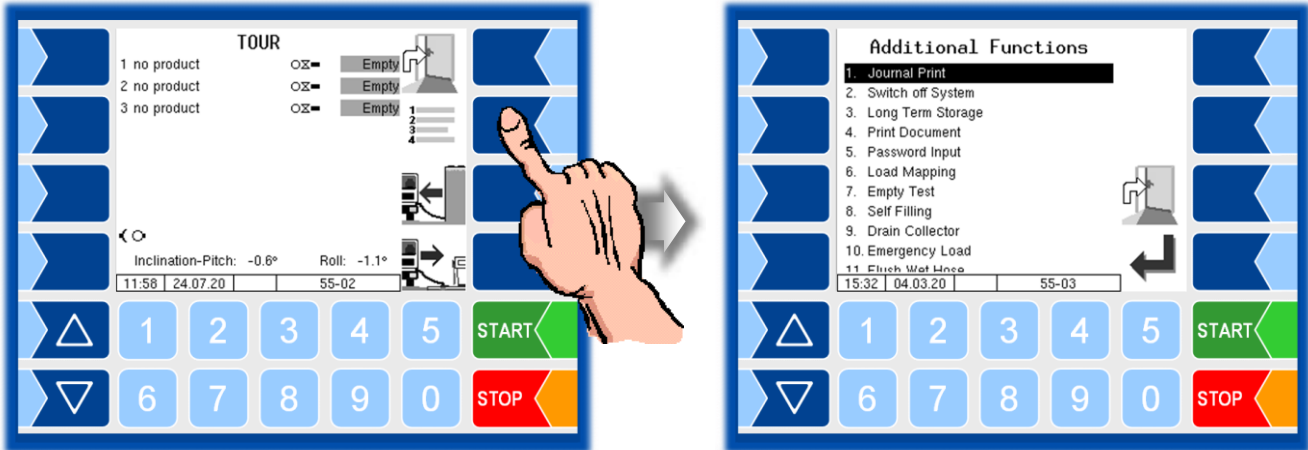

The following menu items are available only within a tour: „Load mapping“, „Empty test“, „Self Filling“, „Drain Collector“ (only for collector vehicles), „Flush Wet Hose“, „Delivery from the trailer via the truck counter“, „Emergency Load“ (only in the event of hardware faults), „Transfer from Trailer“, „Fehler! Verweisquelle konnte nicht gefunden werden.“.

6.1 Journal Print

The journal print function allows you to print out the stored tour data.

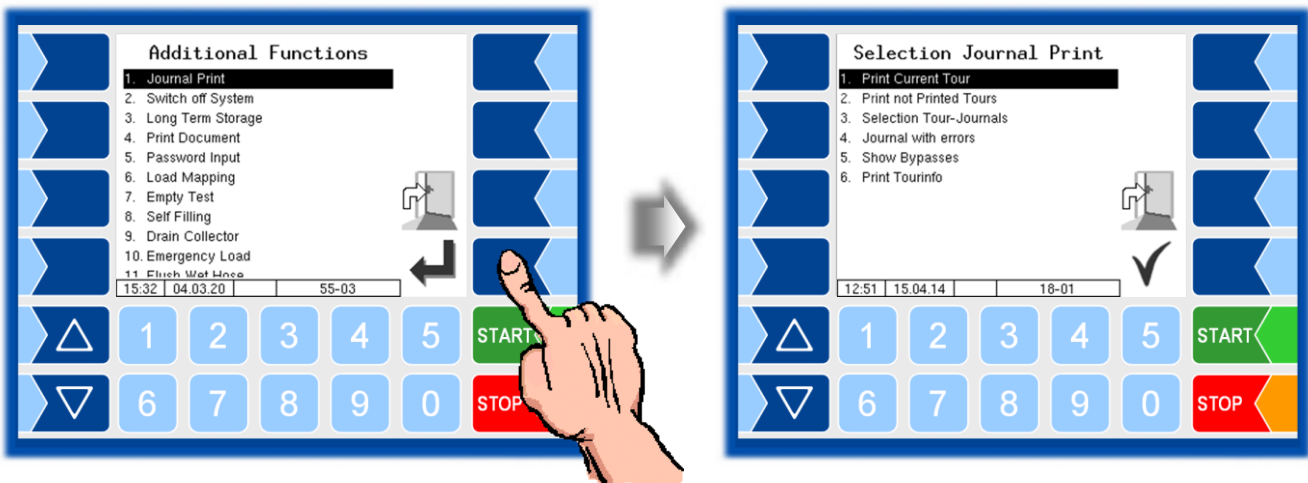

Further selections are possible in the journal print submenu.

6.1.1 Print Current Tour

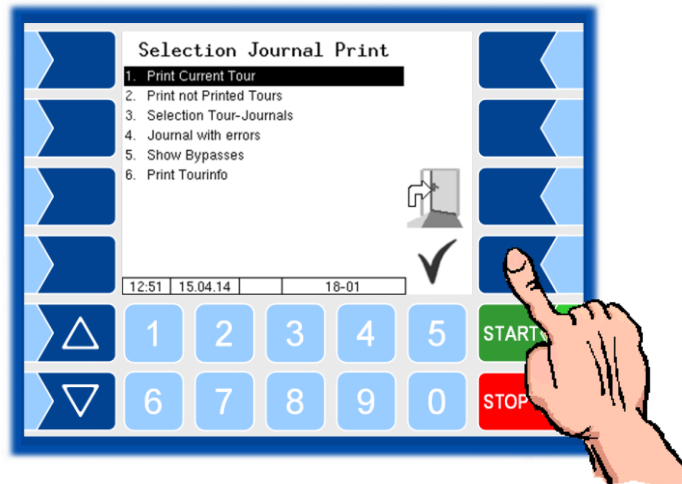

The data for the current (last) tour is printed.

6.1.2 Print not printed Tours

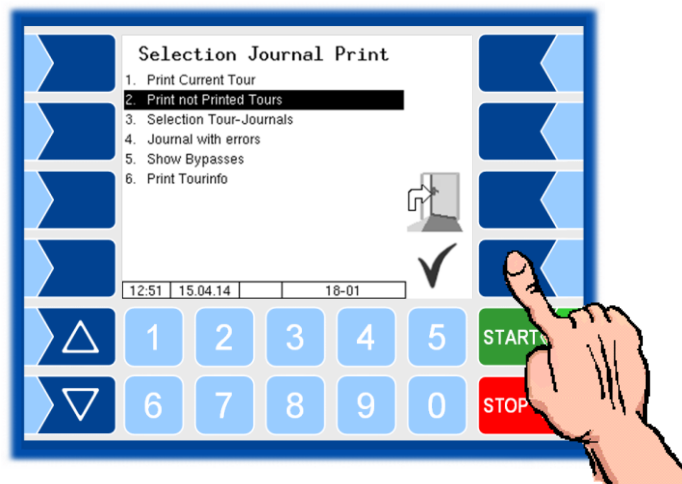

The data for all stored tours that have not yet been printed will be print.

6.1.3 Selection Tour-Journals

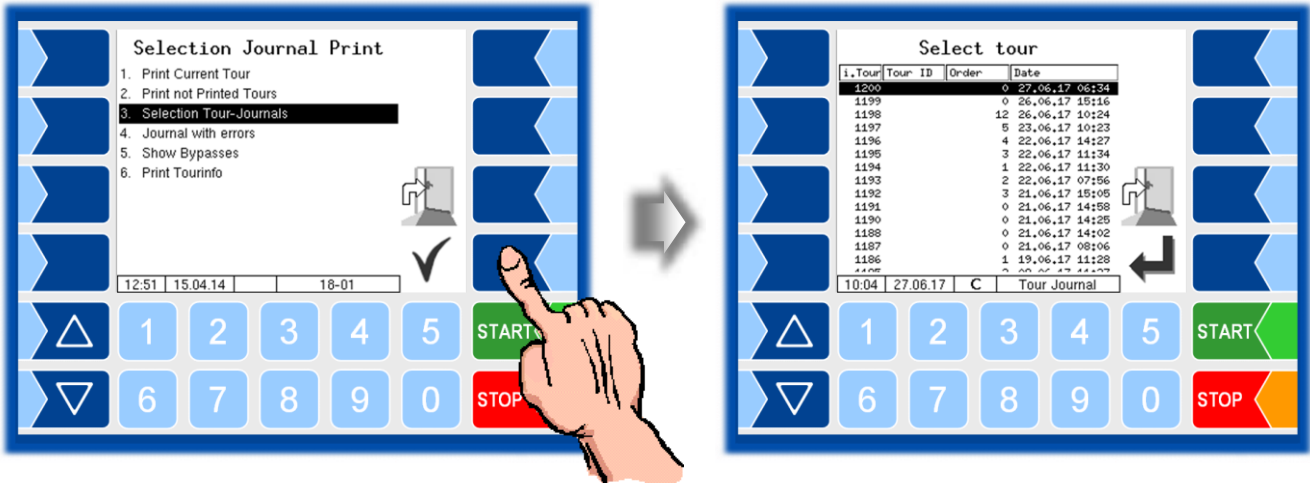

You can use the date and the tour start time to select the tour for which you want to print data.
 Loadings are listed in the tour journal with the order number 0000.

starting level totalizer (uncompensated) starting level totalizer (compensated)

Order	L	Start	P	uncomp	Temp	comp	C
0000	002L	10:49	2	0	51.5	0	1
0000	002L	10:49	2	0	52.2	0	2
0364	014L	13:36	2	537	51.6	520	1
0366	014L	13:36	3	545	52.2	520	2

sequential order no. (0000 = loading)

internal order no. L= Delivery Note

start time loading / order product number

compartment number (calibrated deliveries are marked with a *)

compensated quantity

average temperature

uncompensated quantity

compensated quantities

final level totalizer (uncompensated) final level totalizer (compensated)

Example Journal Print

6.1.4 Journal with errors

In this menu you can select from the stored log journals. The log-journals also contain all recorded errors.

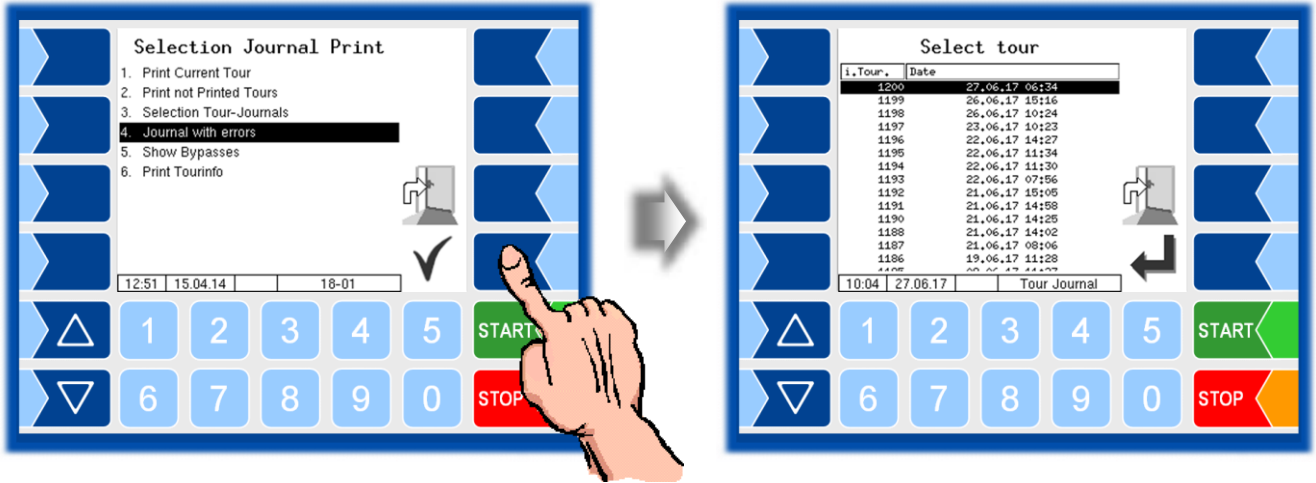

- First select the tour from which a log journal shall be displayed or printed

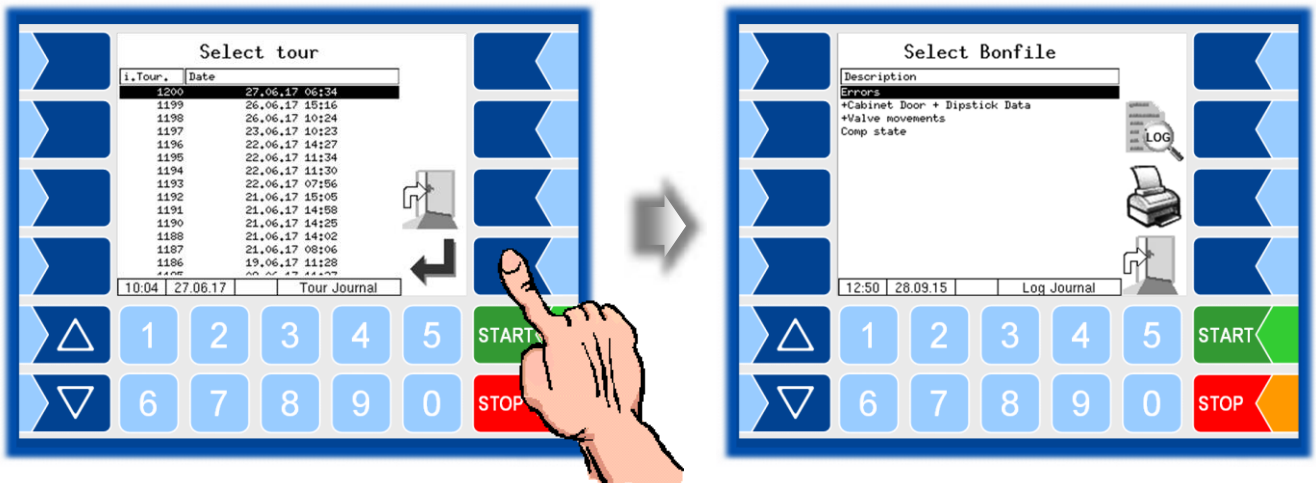

- Then select the contents of the log journal based on the bonfile.

Bonfile	Content
Errors	Log journal with recorded errors
+Cabinet Door +Dipstick Data	Log journal with recorded errors + movements of the cabinet doors and dipstick data (bearings) *
+Valve movements	Log journal with recorded errors + movements of the cabinet doors and dipstick data + valve movements
Comp. state	recorded compartment states (Compartment History)

* If there is GPS data, it will only print from here.

- By touching the "Print Preview" softkey you can view the selected log data on the display. Use the arrow keys to scroll the screen
- By pressing the "Print" Softkey is the log journal printed on the configured printer.

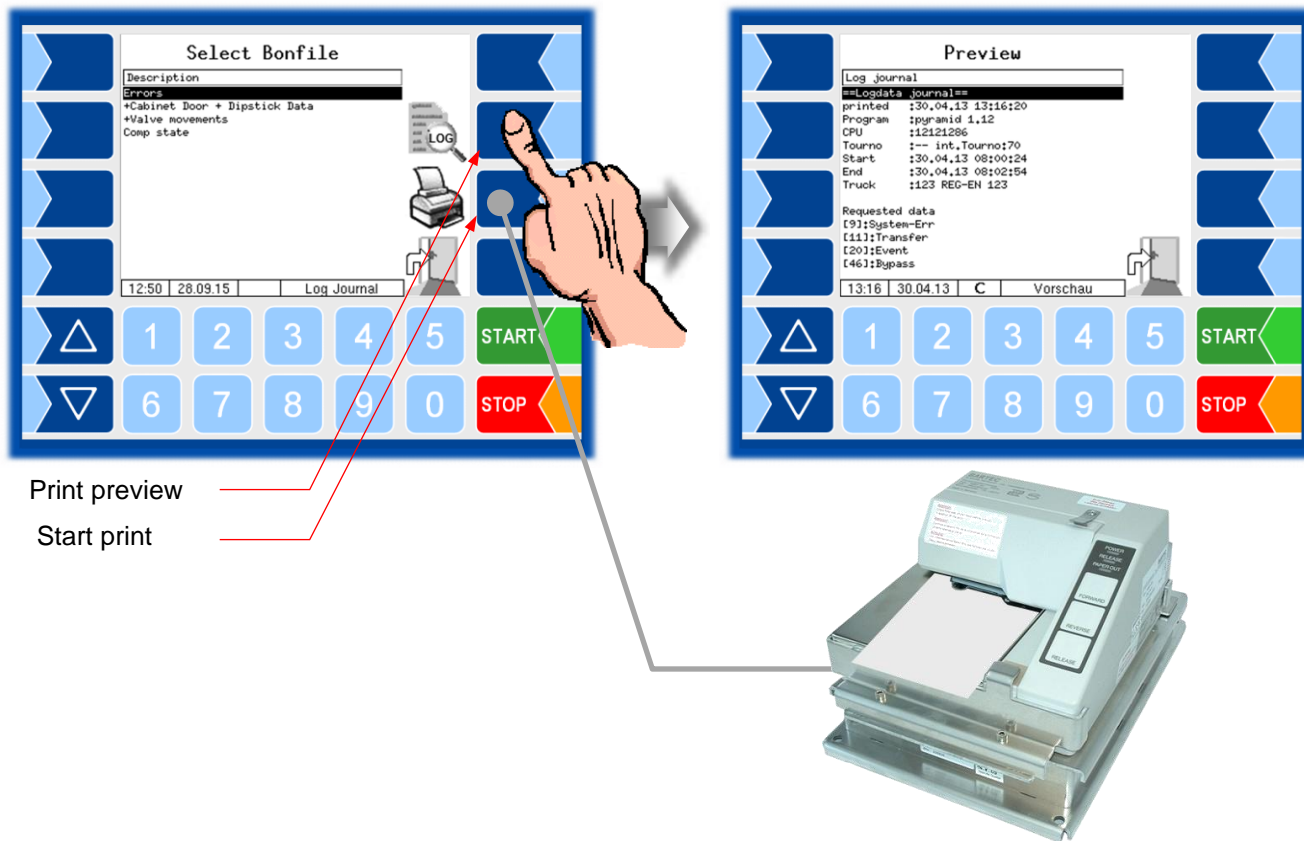

Print preview

Start print

Reportings from SAFE-components

State of inputs

State of the wetleg sensors

Dipstick data

C: compartment number
 Prd: product-no.
 metrological product (measured product)
 VT: quantity uncompensated
 V15: quantity compensated

```

== Logdata journal ==
printed :05.01.15 15:04:43
Program :pyramid 1.16.23
CPU :12072056
Tourno :-- int.Tourno:4033
Start :03.01.15 05:01:46
End :03.01.15 05:25:37
Truck :REG BB 123

Requested data
[9]:System-Err
[11]:Transfer
[13]:Content
[20]:Event
[40]: Comp state
[42]: Access state
[46]: Bypass

      No C Prd   VT   V15   Tavg
05:01:46 Snapshot Begin
05:01:46 log. Input 1 Open
05:01:46 Cabinet Door left closed
05:01:46 Cabinet Door right closed
05:01:46 Pressure 6 closed
05:01:46 C 1 WLS 10 Wet
05:01:46 C 2 WLS 11 Wet
05:01:46 C 3 WLS 12 Wet
05:01:46 C 4 WLS 13 Wet
05:01 C 1 Loaded
05:01 C 2 Loaded
05:01 C 3 Loaded
05:01 C 4 Loaded
05:01:46 Snapshot End
05:01 Content:C 1 Prd 3 (5) VT 7031 1
05:01 Content:C 2 Prd 3 (5) VT 13006 1
05:01 Content:C 3 Prd 5 (11) VT 3613 1
05:01 Content:C 4 Prd 2 (2) VT 11986 1
05:01:49 Snapshot Begin
05:01:49 log. Input 1 Open
05:01:49 Cabinet Door left closed
05:01:49 Cabinet Door right closed
05:01:49 Pressure 6 closed
05:01:49 C 1 WLS 10 Wet
05:01:49 C 2 WLS 11 Wet
05:01:49 C 3 WLS 12 Wet
05:01:49 C 4 WLS 13 Wet

05:12 C 1 Rest
05:12 C 1 Rest
05:21:17 C 4 WLS 13 dry
05:21 C 4 Rest
05:21 55-0-1-22-0 Pyramide Compartment 1
      OFP plug %d Tank overfilled
05:21:24 C 2 WLS 11 dry
05:21 C 2 Rest
05:21 C 4 Empty
05:21 C 2 Empty
05:22 *1824 4 2 11986 12082 5.5
05:22 C 4 Empty
05:22 55-0-1-21-0 Pyramid Compartment 1
      OFP plug %d heating up Overfill prevention
      or Tank overfilled
05:23 *1825 2 3 13007 13195 2.9
05:23 C 2 Empty
05:23:16 C 1 WLS 10 dry
05:23 C 1 Rest
05:23 C 1 Empty
05:24 *1827 1 3 7031 7132 3.1
05:24 C 1 Empty
05:24 Content:C 1 Prd 3 (5) VT 0 1
05:24 Content:C 2 Prd 3 (5) VT 0 1
05:24 Content:C 3 Prd 5 (11) VT 0 1
05:24 Content:C 4 Prd 2 (2) VT 0 1
05:24:03 Delivery End
05:25 Content:C 1 Prd 3 (5) VT 0 1
05:25 Content:C 2 Prd 3 (5) VT 0 1
05:25 Content:C 3 Prd 5 (11) VT 0 1
05:25 Content:C 4 Prd 2 (2) VT 0 1

-----
Product sum
Prd   Delivery      Loading
      uncomp   comp   uncomp   comp
-----
  2   11986   12082         0         0
  3   20038   20327         0         0
  5    3612    3665         0         0
-----
      35636   36074         0         0
Page 2/ 2
            
```

Example journal with errors (+Cabinet Door +Dipstick Data)

```

Compartment History
Tourno :-- int.Tourno:20
Start :28.09.15 15:24:34
Driver :11
Truck :1 REG-EN 123
28.09.15
15:24 Start Loading 1 Empty
      Diesel
15:24 Start Loading 2 Empty
      Diesel
15:24 Start Loading 3 Empty
      Diesel
15:25 End Loadins 1 Loaded
      sealed
15:25 End Loadins 2 Loaded
      sealed
15:25 End Loadins 3 Loaded
      sealed
15:25 Start Delivery 1 Loaded
      Diesel
      sealed
15:25 Start Delivery 2 Loaded
      Diesel
      sealed
15:25 Start Delivery 3 Loaded
      Diesel
      sealed
15:26 End Delivery 1 Empty
      sealed after delivery
15:26 End Delivery 2 Empty
      sealed after delivery
15:26 End Delivery 3 Empty
      sealed after delivery
            
```

Example Compartment state

6.1.5 Show Bypasses

Use this menu item to display the performed bypassings of the quality safe system SAFE.

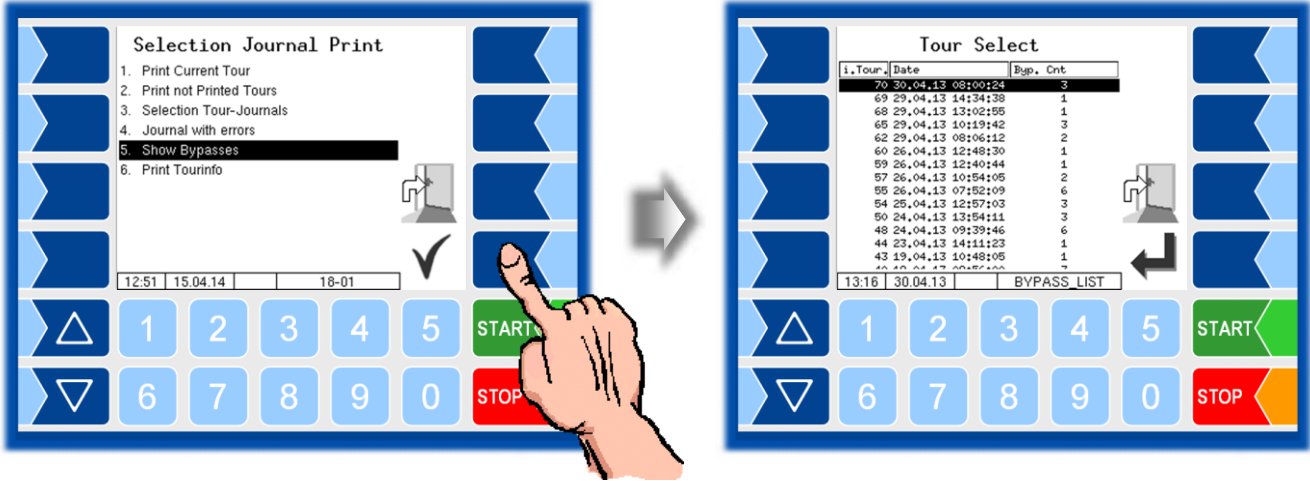

Select and confirm a tour. Details of the bypassing during this tour are displayed: date, time, SAFE module which was bypassed. If a GPS module is installed, additionally the corresponding position data is displayed.

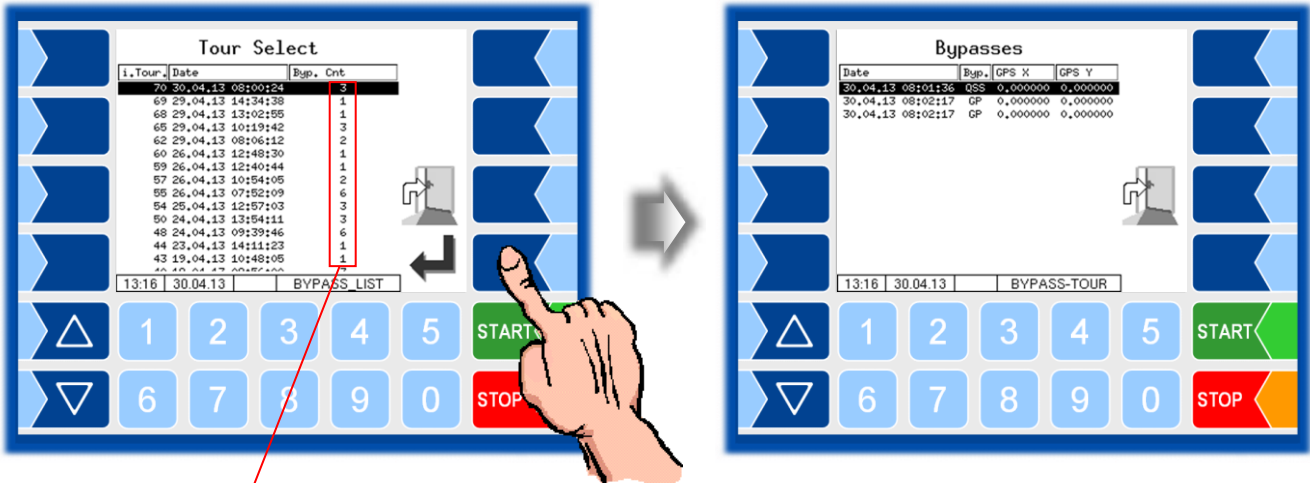

Number of bypasses performed in the tour

6.1.6 Print Tourinfo

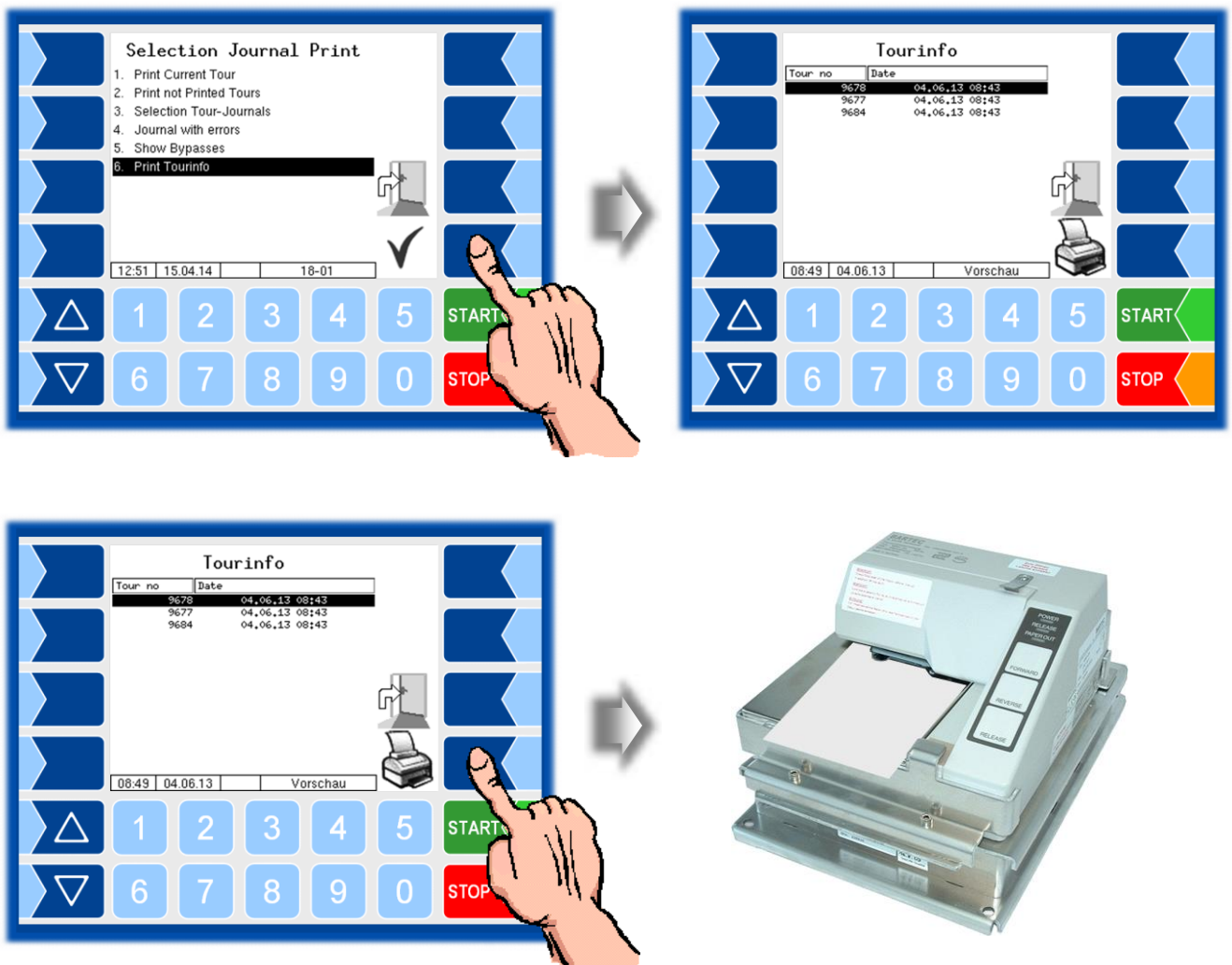

When working with an office connection, the tour data of the last 7 days is stored. You can select a tour here and output the information about the selected tour produced by the office on the printer, if this option is supported by the office.

6.2 Switch off System

- Select the “Switch off System” menu from the Additional Functions menu. The system is switched off properly, shutting down all modules.

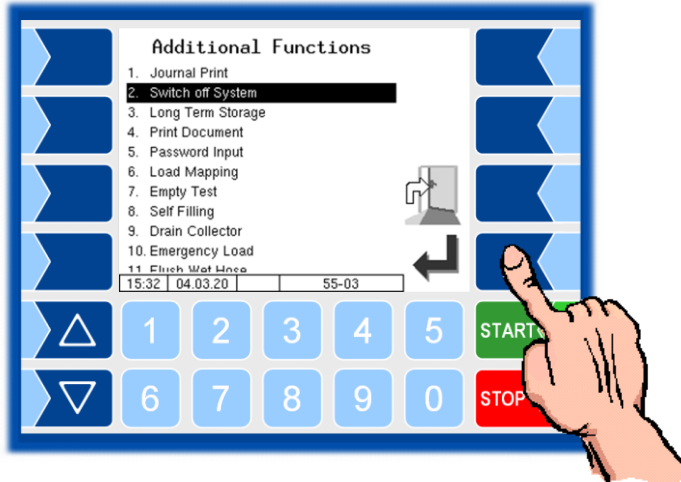

Even after “Switch off System”, voltage is present.

Always turn off the main power switch for maintenance!

The main switch may not be switched off until the system has been fully shut down properly!

6.3 Long Term Storage (3 months storage)

You can open the *Long term storage* also in the Service menu (see section 5.3.1).

Long Term Storage stores the tour data for three months. Within this time, you can view or print duplicates of the documents.

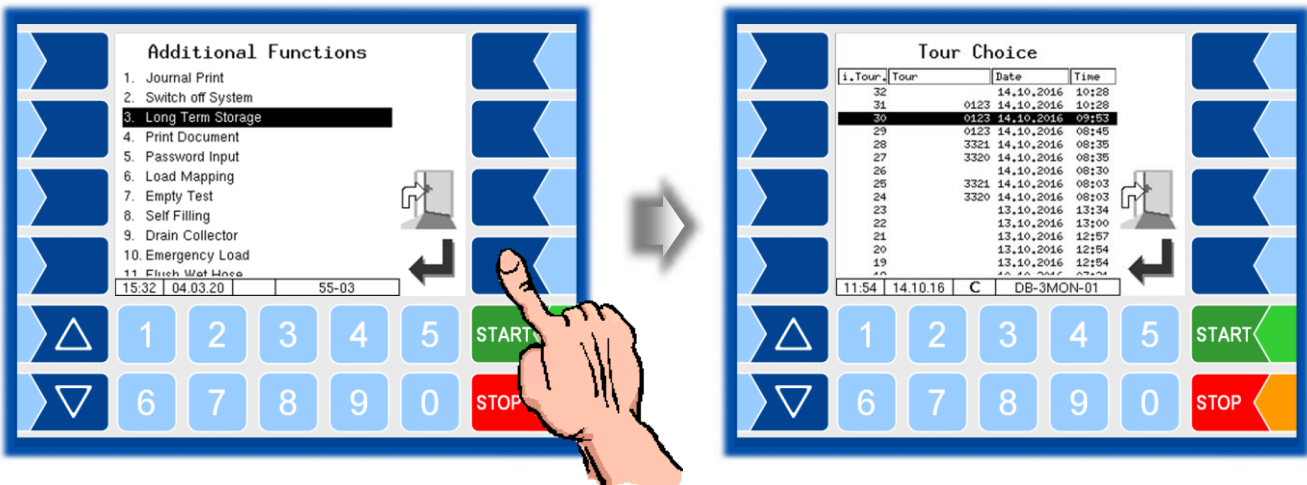

- Select a tour.

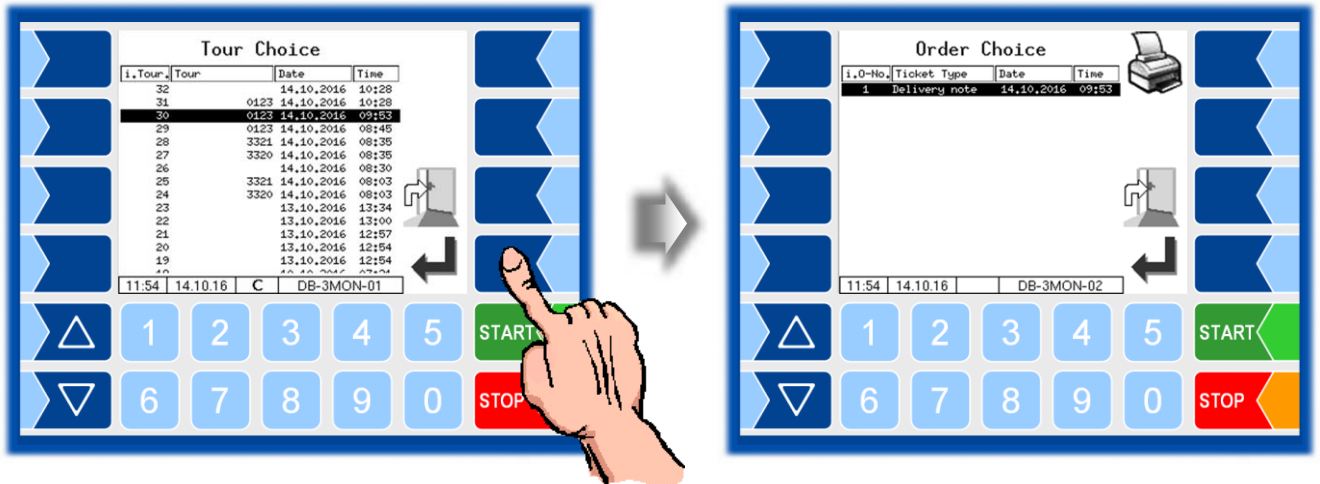

- Select an order within the tour.

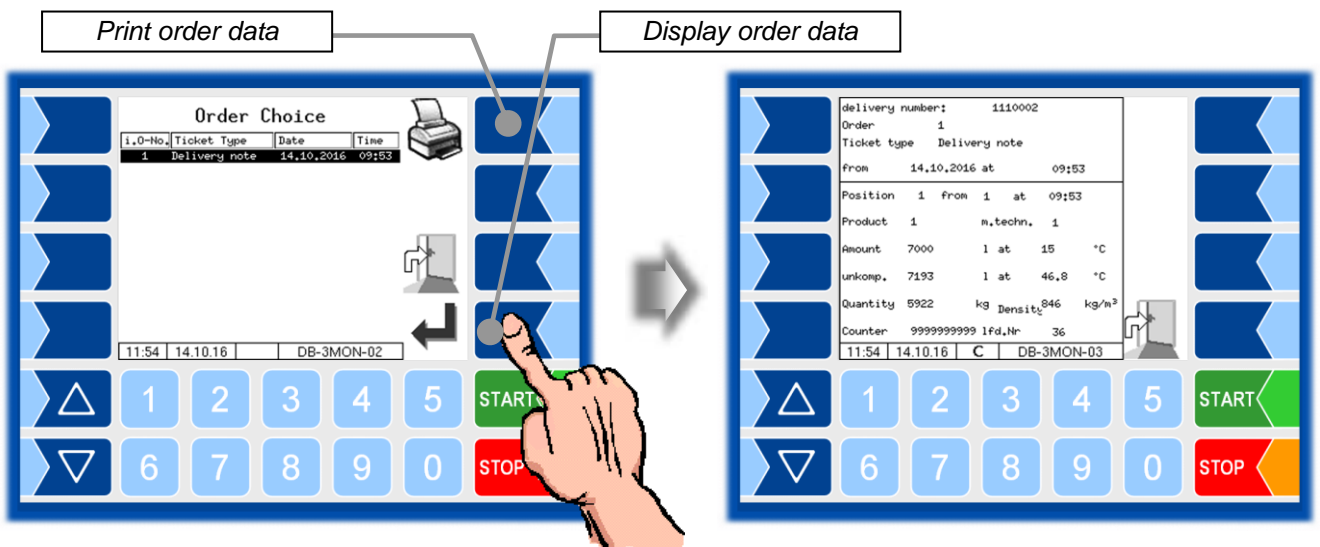

If the order contains more than two items, you can select the required item using the ∇ and \triangle keys.

The print is a duplicate of the original document.

6.4 Print Document

You can print as many duplicates of the delivery note as you like for the last order. The duplicate differs from the original only in that the word "Duplicate" and the duplicate's sequential number are output at the start of the printout. You can print duplicates of older orders using the long-term memory (see section 6.3).

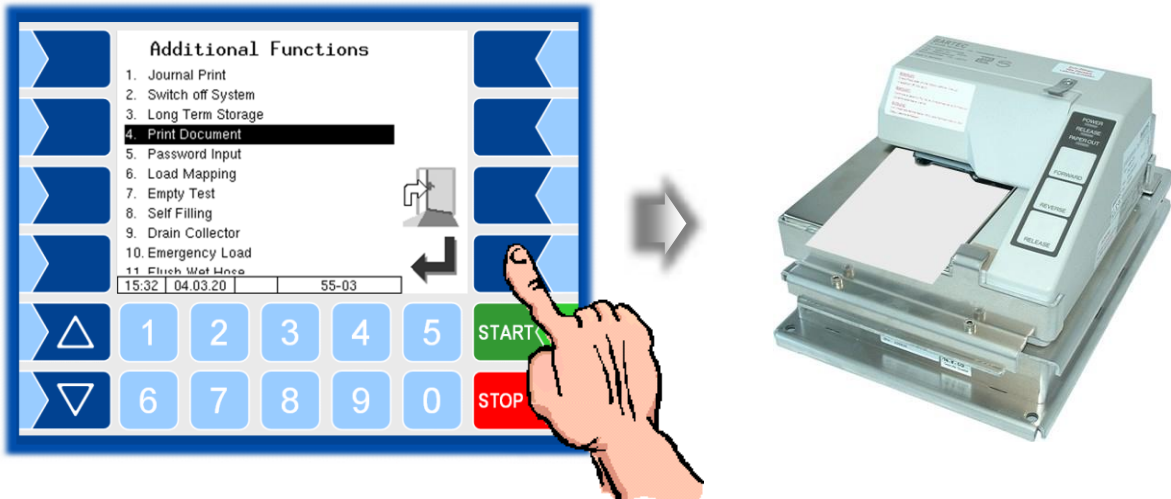

6.5 Password Input

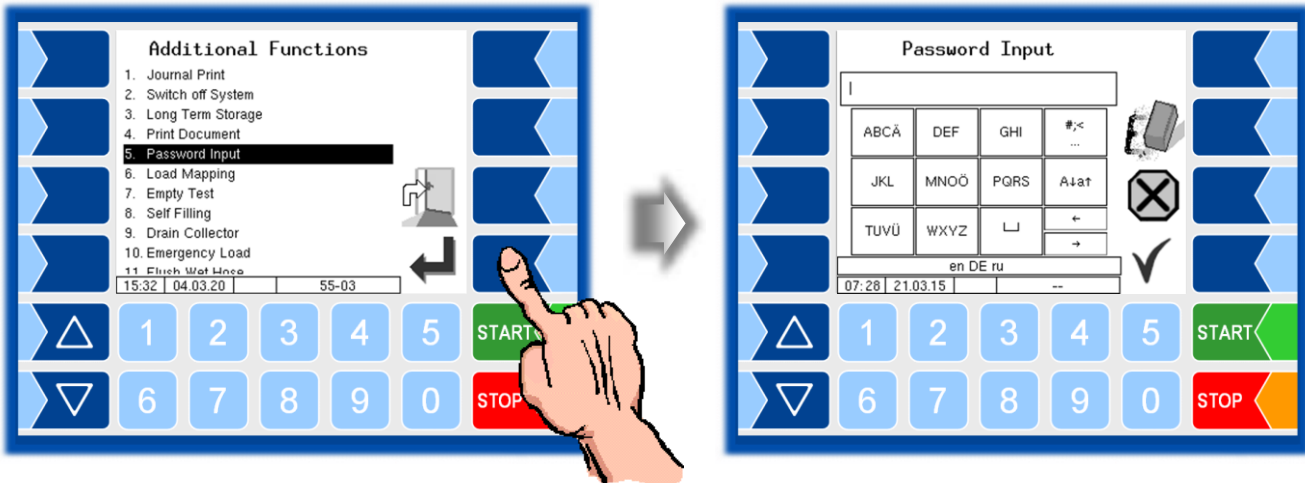

A password is required for various functions that can be used in cooperation with trained service personnel. To do this, contact your service point. The password is entered as described in section 5.1.

6.6 Load mapping



With the load mapping you can specify the products in the compartments. After loading, the "Compartment Product Mapping" window is opened when you exit the loading menu (see section 4.2.3).

If different products have been loaded under the same product code (e.g. several types of gasoline), you can select the specific products for the compartments here.

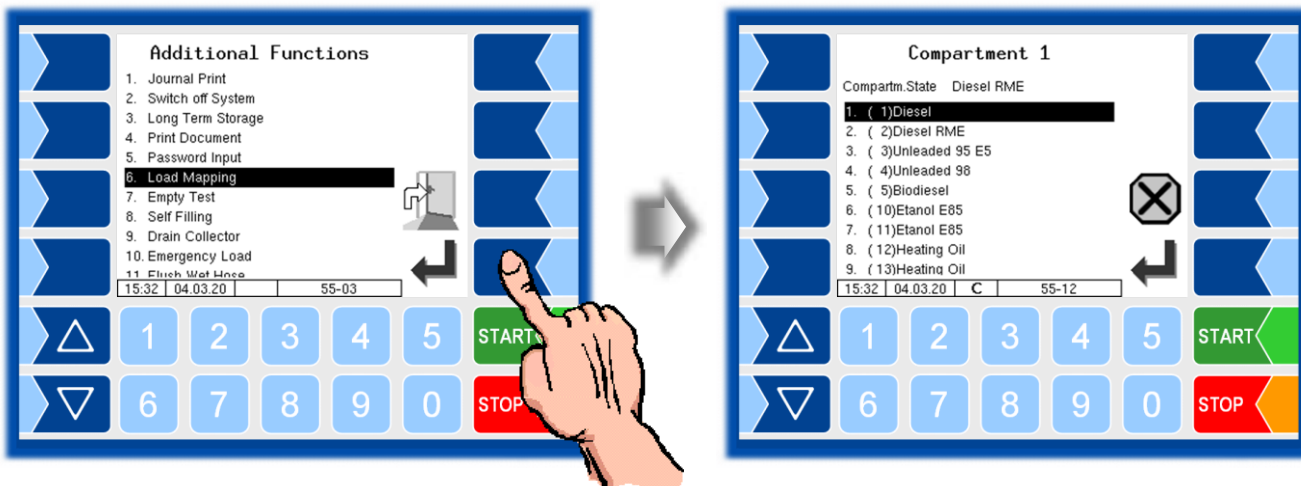

- Select the line for the respective compartment and touch the "Confirmation" softkey.

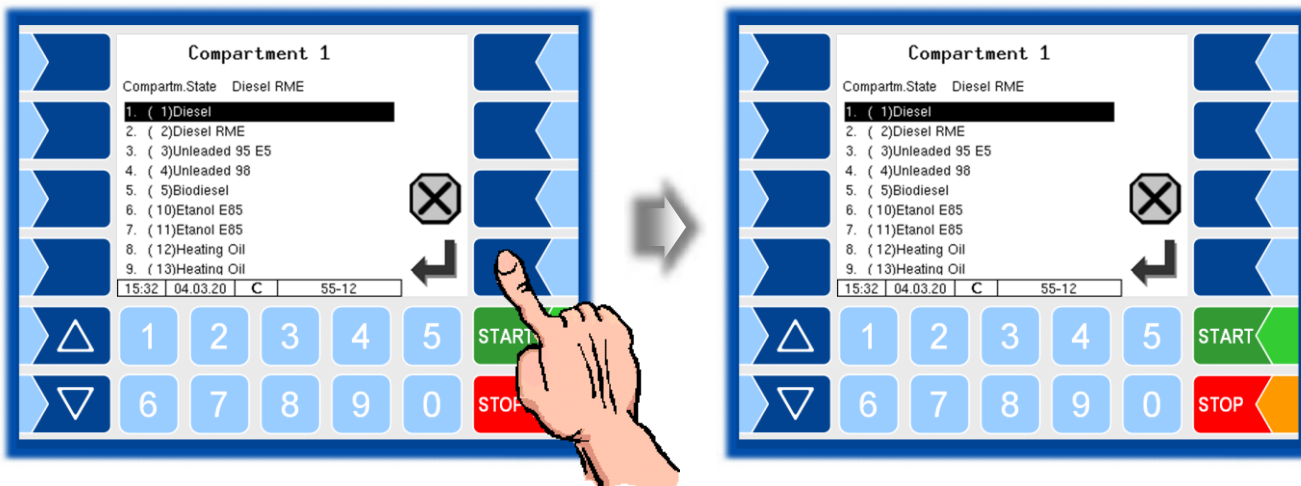

All configured products are shown in the display.

- Confirm the product which was loaded into the selected compartment.



Load mapping is not available, when Delivery Mapping is active.

6.7

Delivery Mapping



If configured, the product name can be changed prior to delivery. Thus, a product can be delivered under different names, or even additivated.

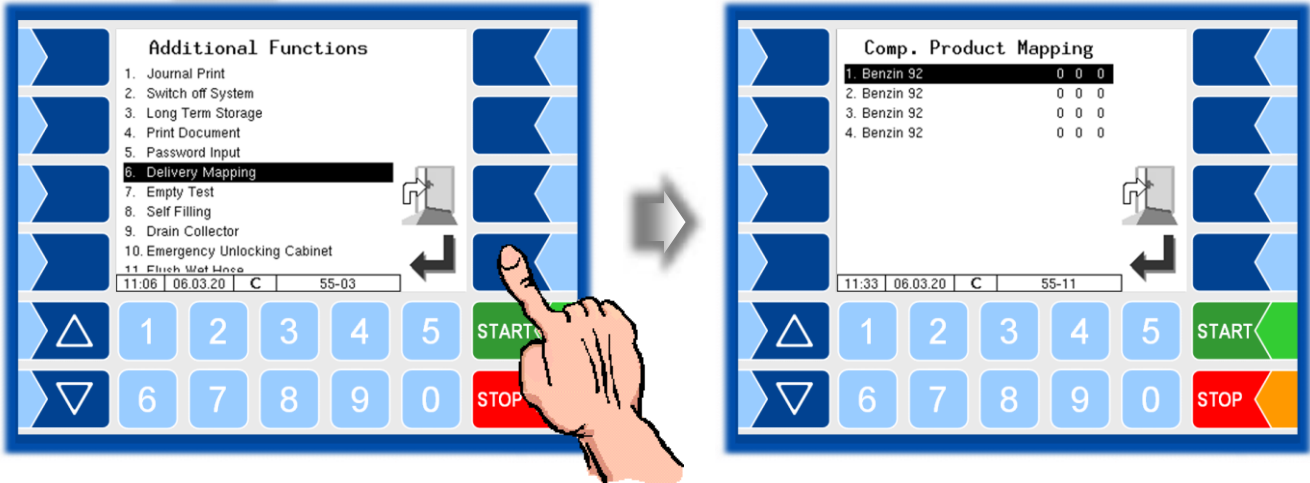

- Select the line for the respective compartment and touch the "Confirmation" softkey.

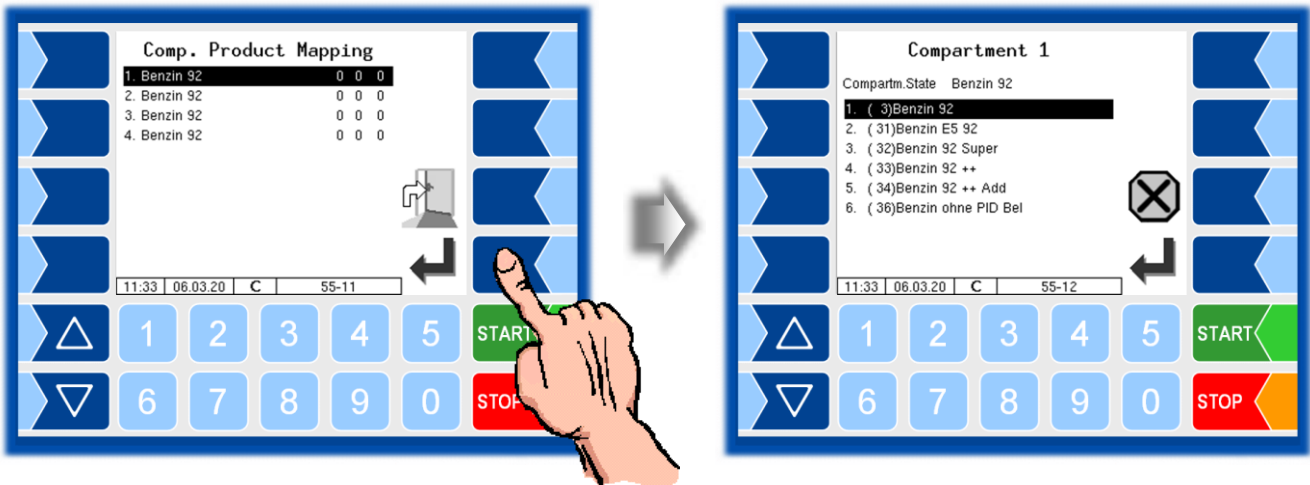

You can now choose the appropriate product from all products configured with the same delivery code.



Delivery Mapping is not available, when Load mapping is active.

6.8 Empty test

To check whether the compartments are empty, you can run an empty test. If an empty test is required before loading (depending on the configuration), the request to carry out an empty test is displayed if it has not yet been carried out or the specified time after the empty test has expired.

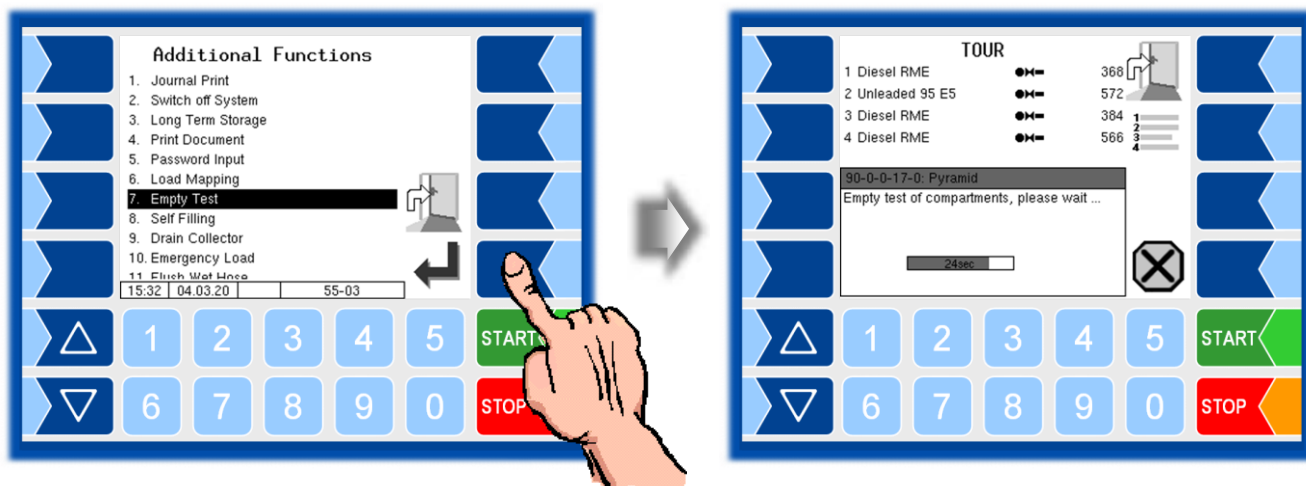

Parameters for configuring the empty test

Control-Parameter	
Max. Delay of Empty Test	Before loading, an empty test must have taken place within the configured time. 0: empty test not required. <i>Default setting: 60 min.</i>
Empty Test despite Volume	yes: The empty-test is also performed when still product is detected in the compartment.
Logical Output 15	
	Switching the compressed air to the bottom valves during an empty test

6.9 Select Company



In order to be able to use this function, BARTEC must create a group-specific B3i file.

If the vehicle is transporting products for several mineral oil companies, the company can be selected here. Various **options for group selection** can be specified in the software configuration.

- The menu item "Select Company" is omitted if the company selection is deactivated in the configuration (Program Parameter / SAFE Oil Company Preset: „no“).
- With manual company selection, the selection can be made in the additional menu. (Program Parameter / SAFE Oil Company Preset: „manual“).
- With automatic company selection, the company is selected before loading (Program Parameter / SAFE Oil Company Preset: „autom.“).
- The vehicle can be automatically switched to a specified group as soon as it is empty (Program Parameter / Default Company on Empty).

A code may also be required for company selection. Various options can be configured for this.

- No code entry is required for company selection (Program Parameter / Change Company with Code: „off“).
- A code must always be entered when choosing a company (Program Parameter / Change Company with Code: „always“).
- A code only has to be entered if the company is selected when the vehicle is loaded (Program Parameter / Change Company with Code: „loaded“).



A change of company is only possible if all compartments are empty.

If there is still product in the compartments, a one-time change of company can take place after entering the service password.

After the change of group, the loaded products must be changed to match the selected group using the load mapping.

The change of company is logged!

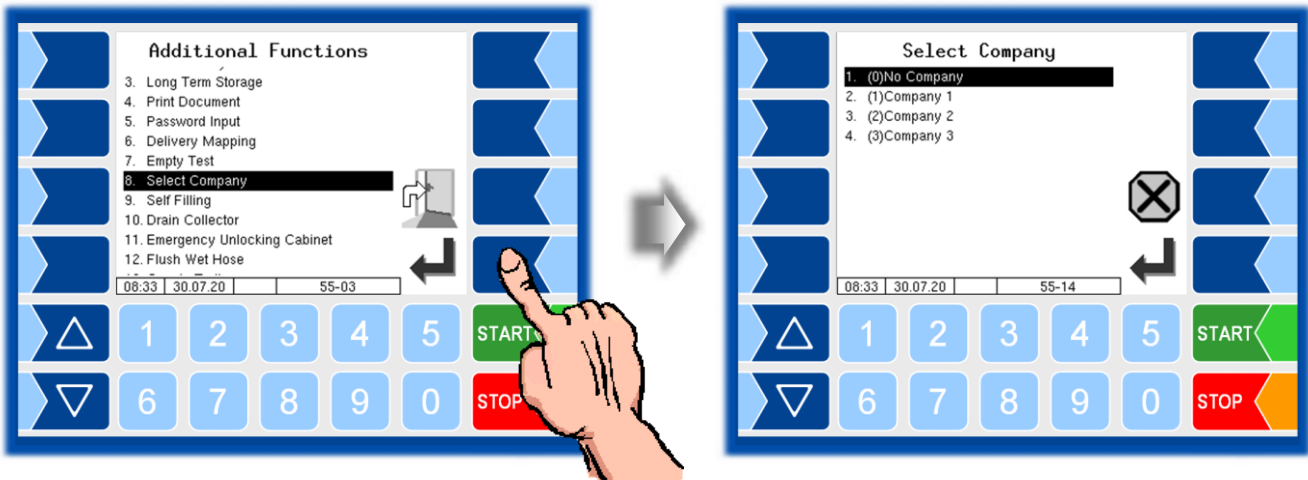

6.10 Self Filling

The "Self-Filling" function is available for collector vehicles for emptying containers.

- After calling up the "Self-suction" function, select the delivery hose.

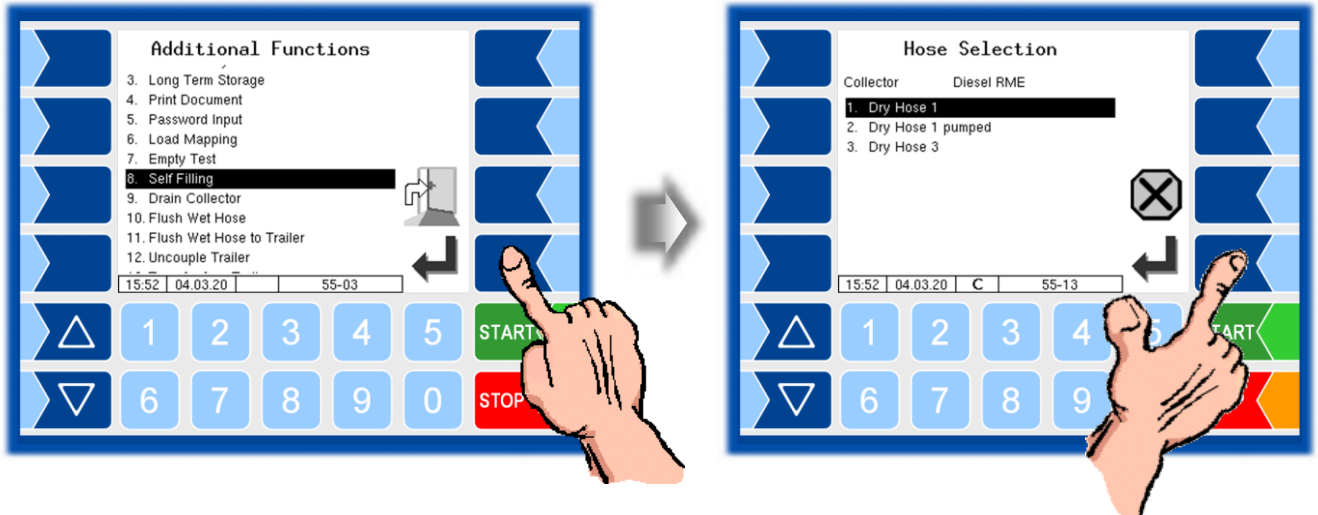

- Select the compartment into which the product is to be pumped.

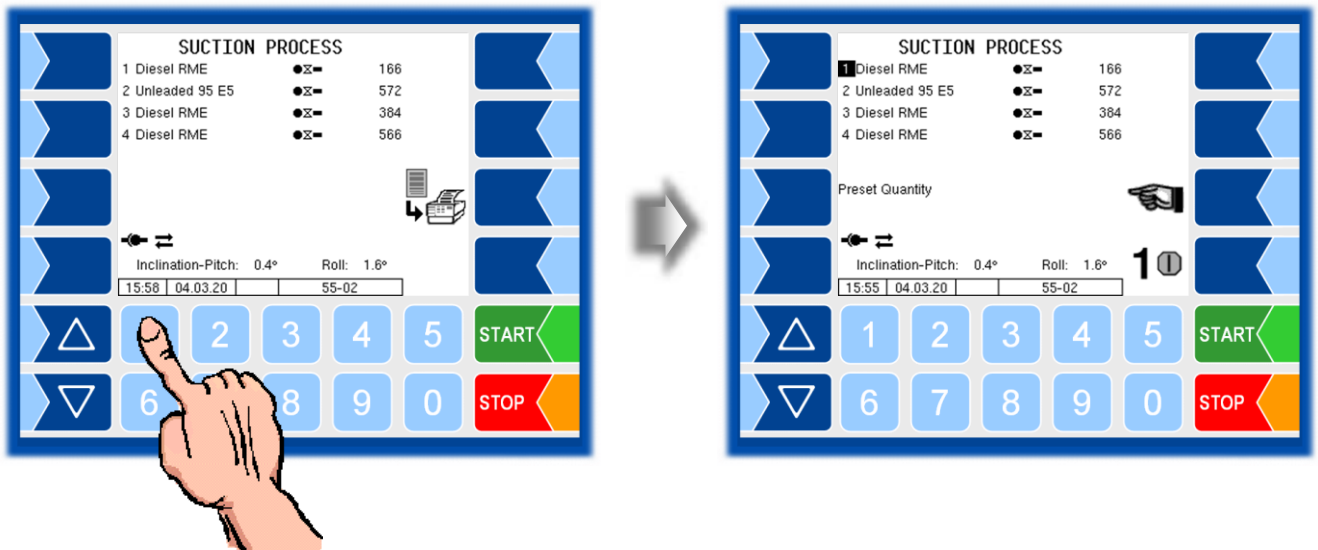

- Optionally, you can enter a preset quantity.

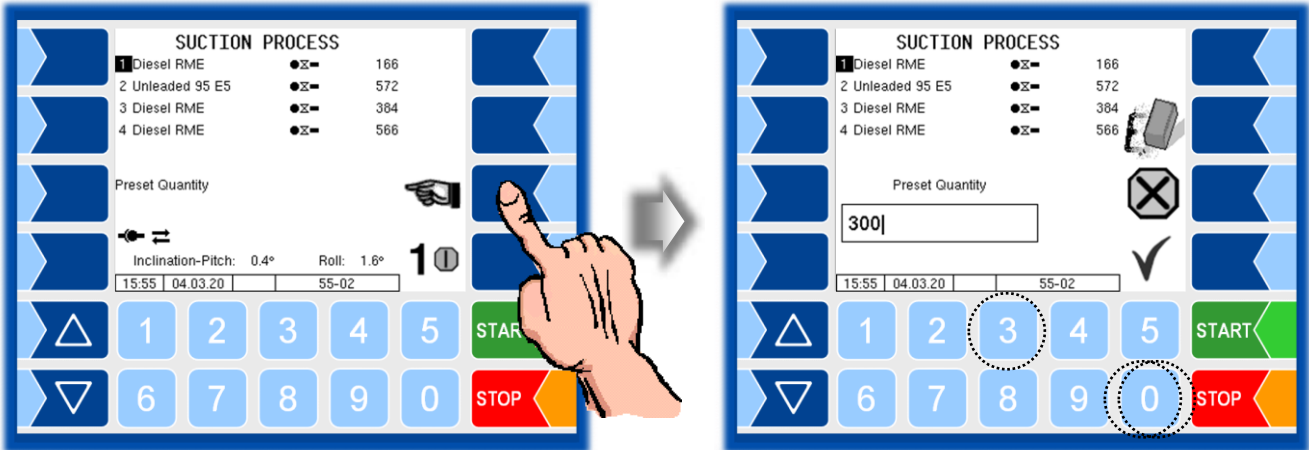

- Start self-suction.

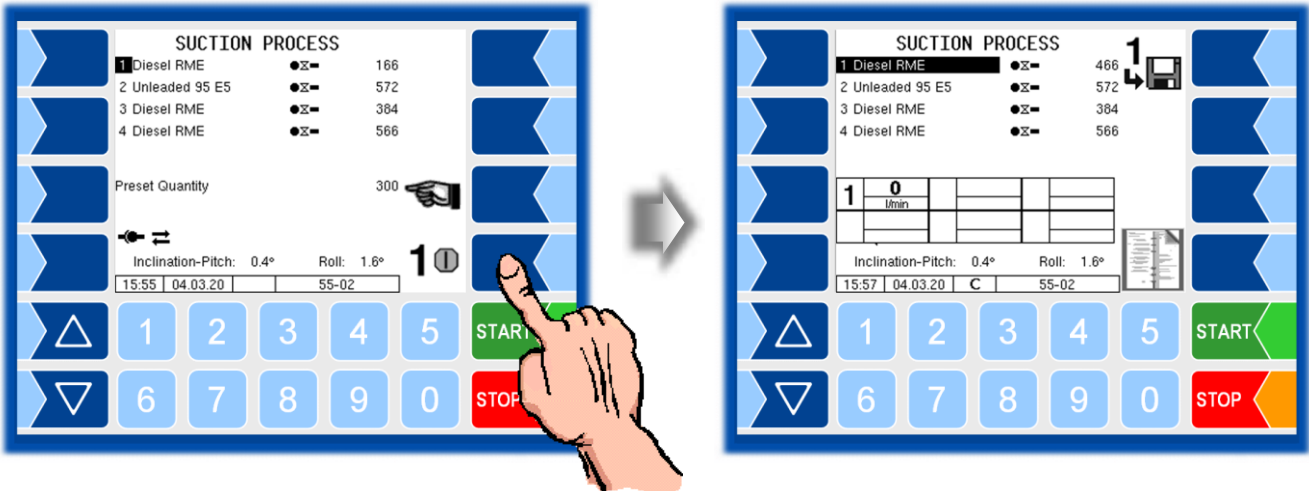

The process is automatically stopped when the preset quantity is reached or when the overfill protection stops the pump.
You can manually stop the self-suction with the **STOP** button.

- Finish the process after the pump has stopped.

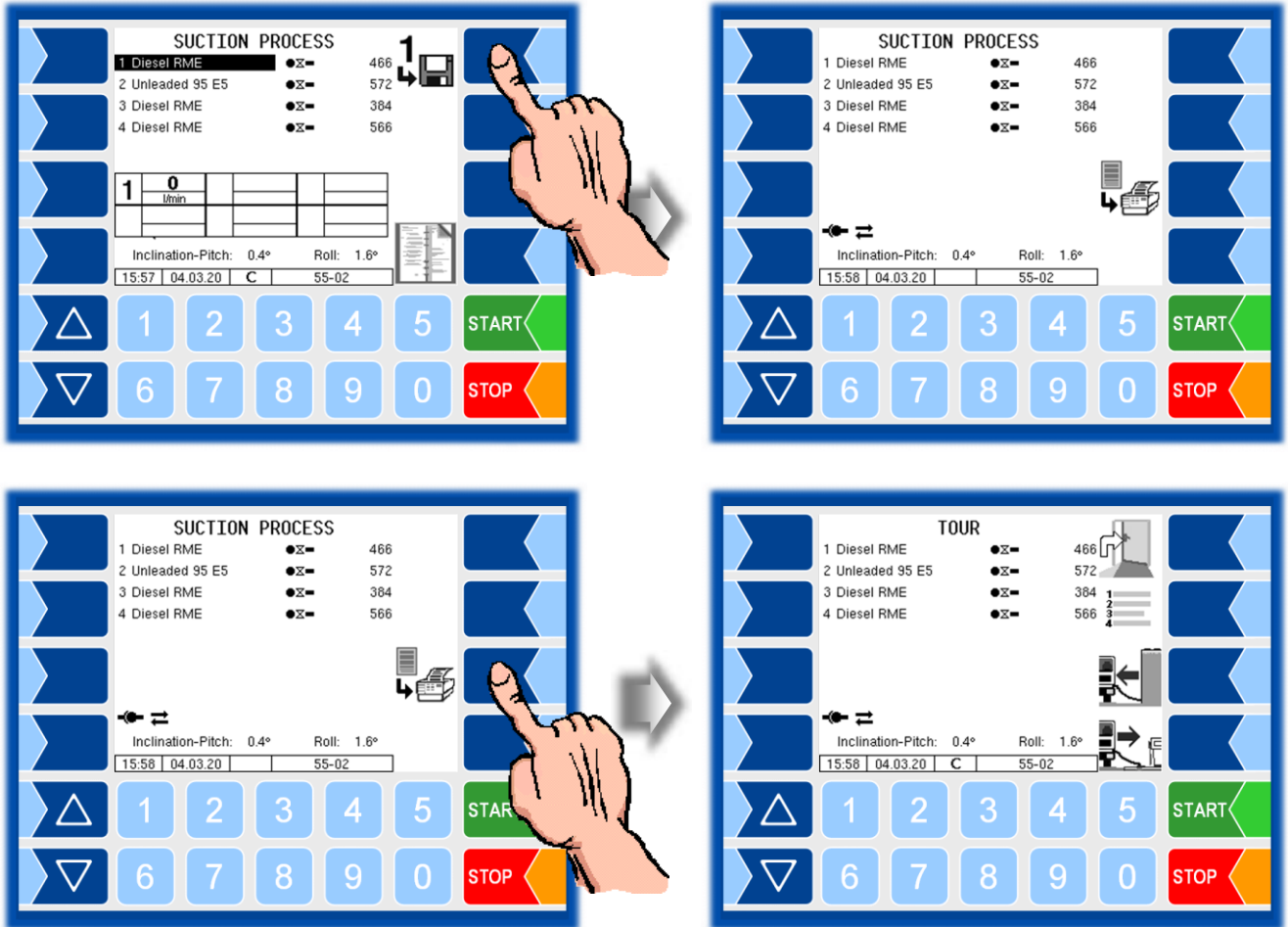

6.11 Drain Collector

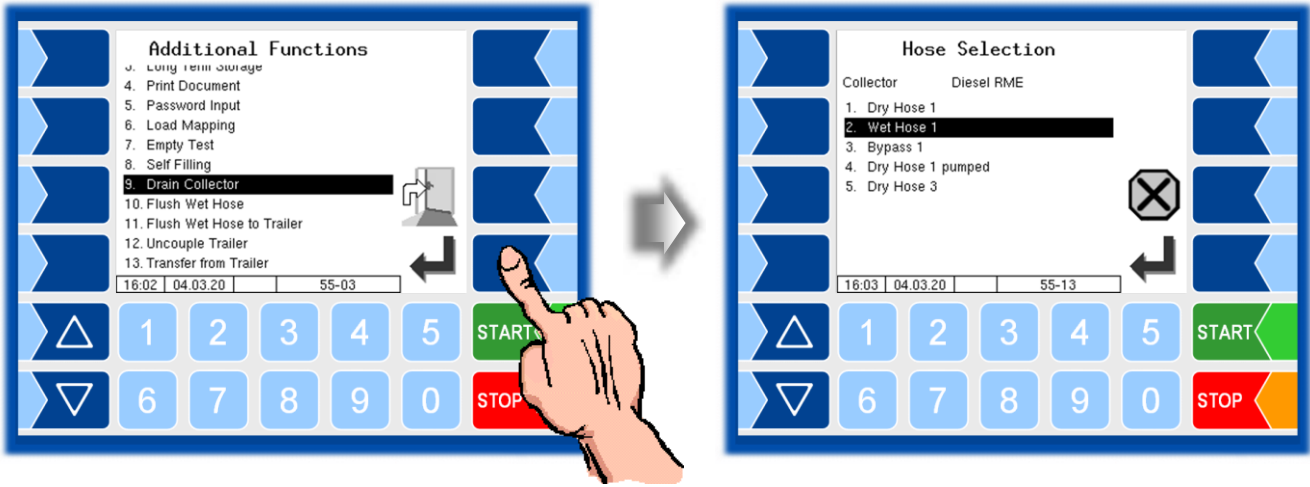

- Select the hose through which the residue is to be removed.
- Start removing residue with the "Confirmation" softkey.

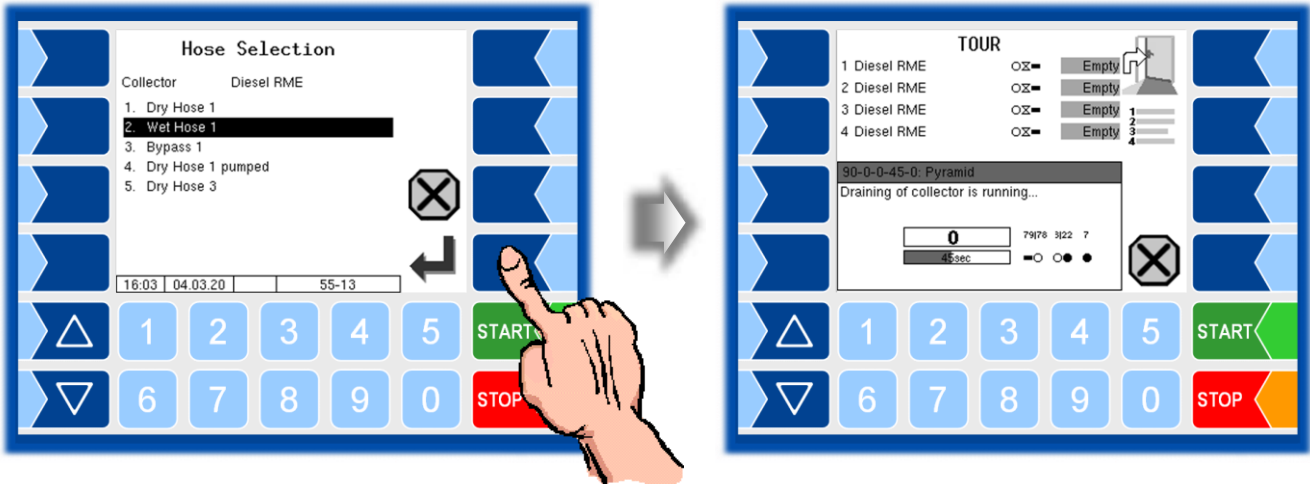

6.12 Flush Wet Hose

If there is a product change for an upcoming order, it is necessary to flush the hose.

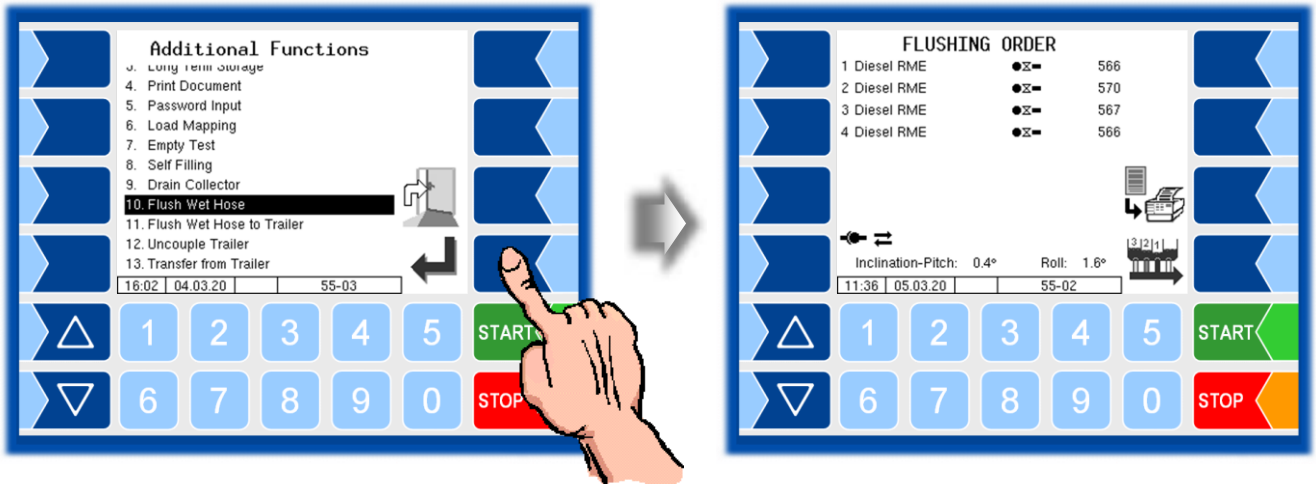

- Touch the collector delivery softkey and then select the hose to be flushed.

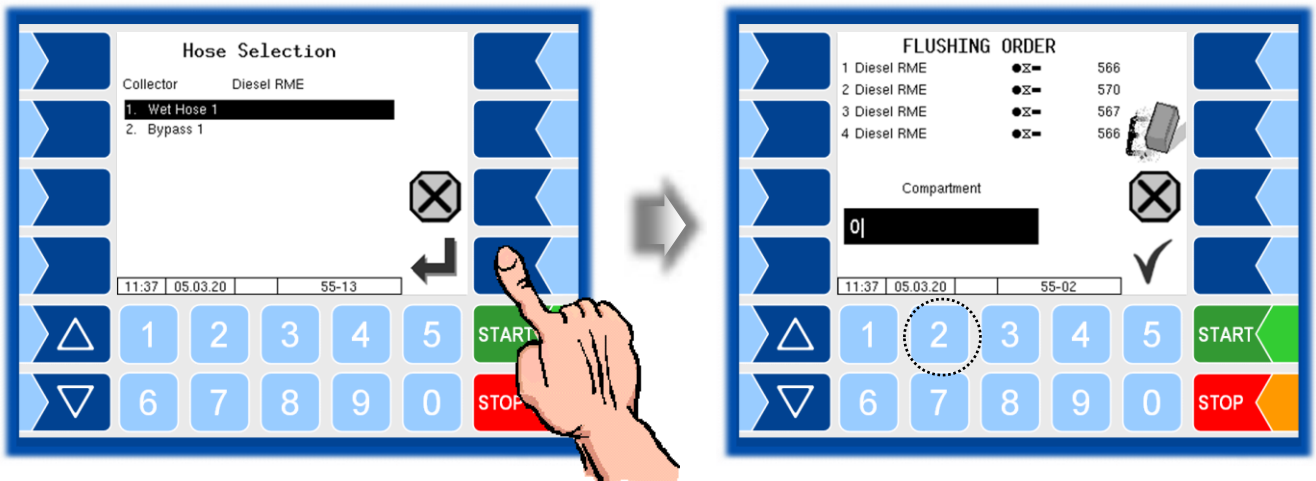
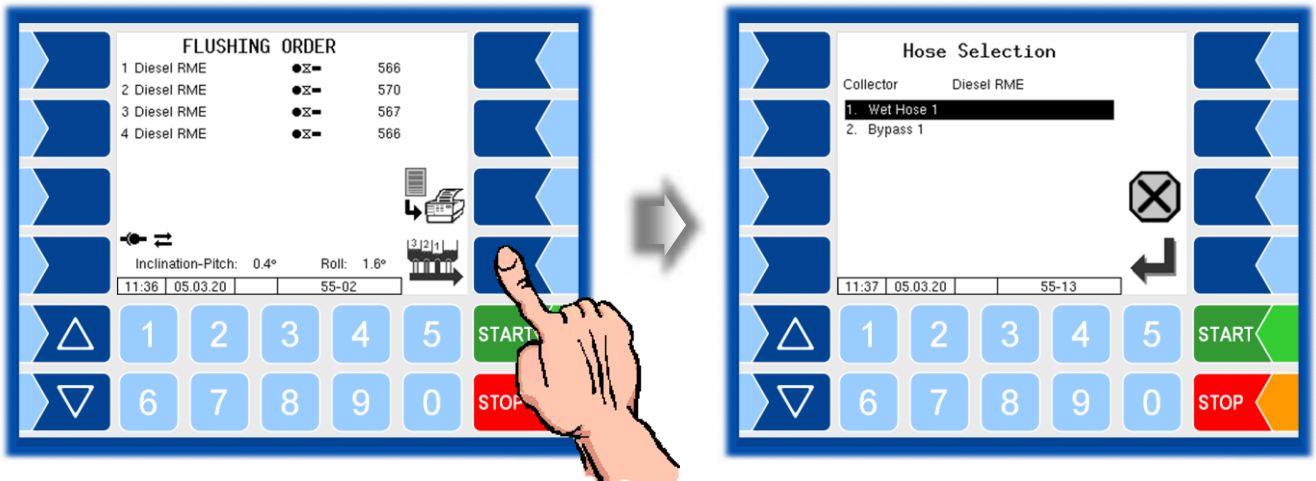

- Enter the number of the compartment from which the flushing product is to be taken.

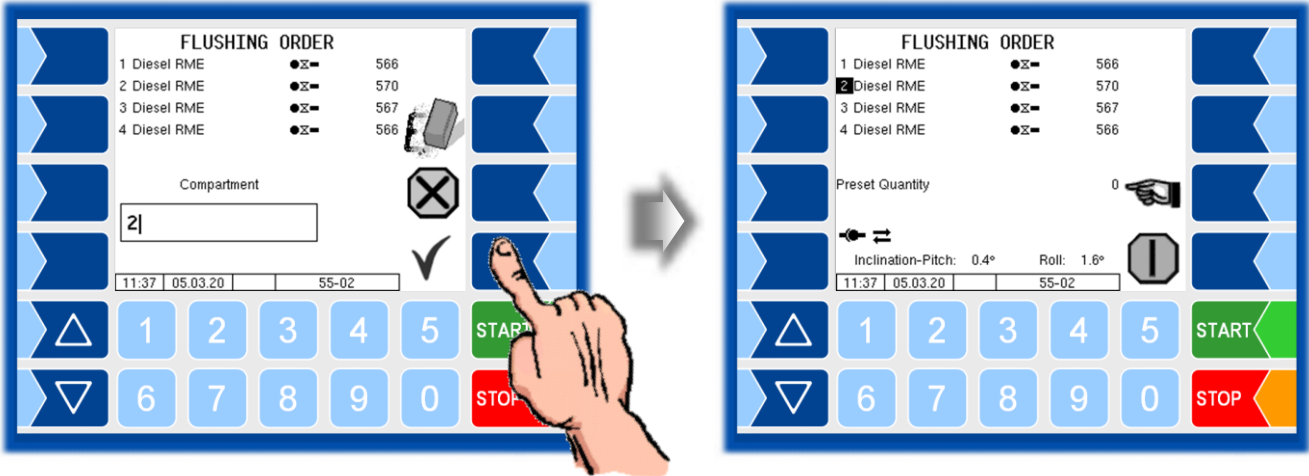

- Enter the quantity with which the hose should be flushed.



The flush volume must ensure that there is no longer any product from the previous delivery in the entire line.

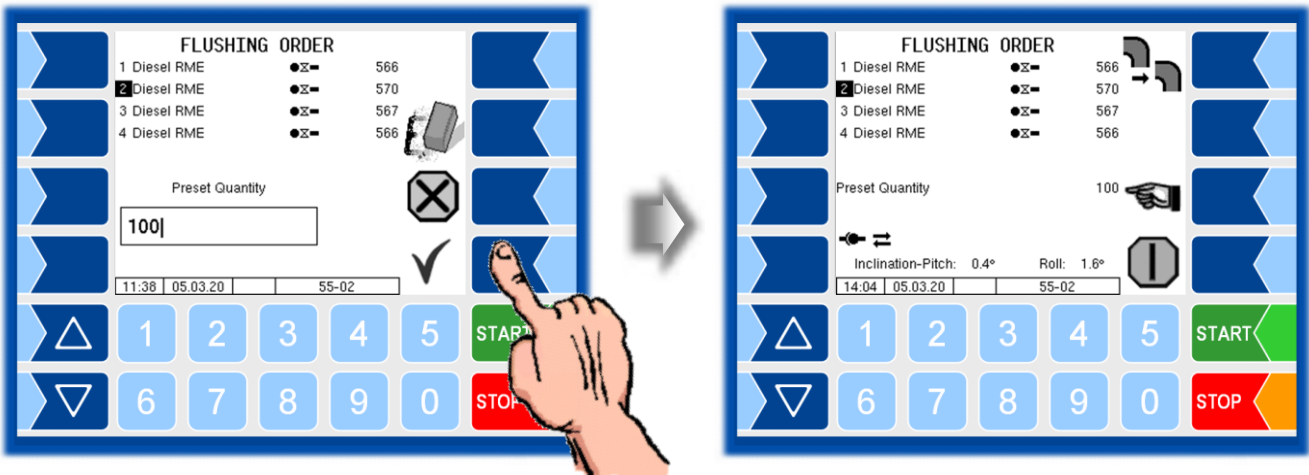
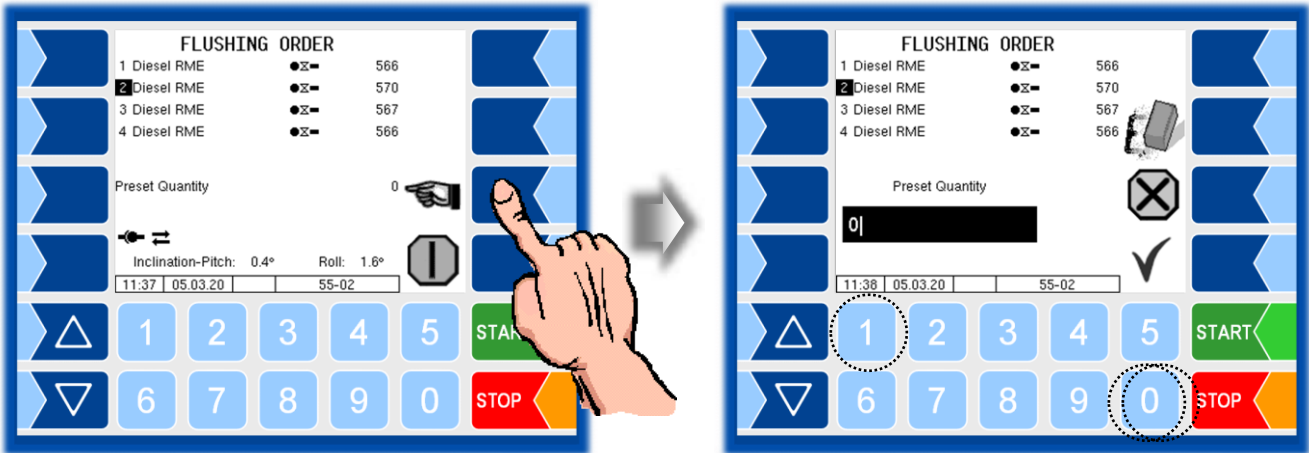

Make the connection of the hose to be flushed to the specified destination tank.



Follow the instructions from your company regarding the selection of the target tank for the flushing product.

- Start flushing with the "Start delivery" softkey“.

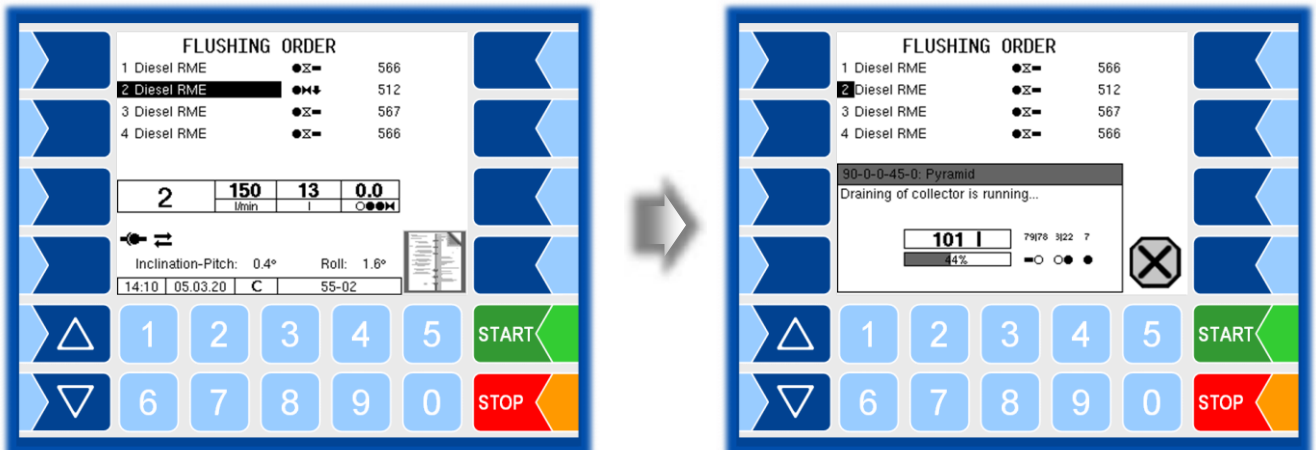
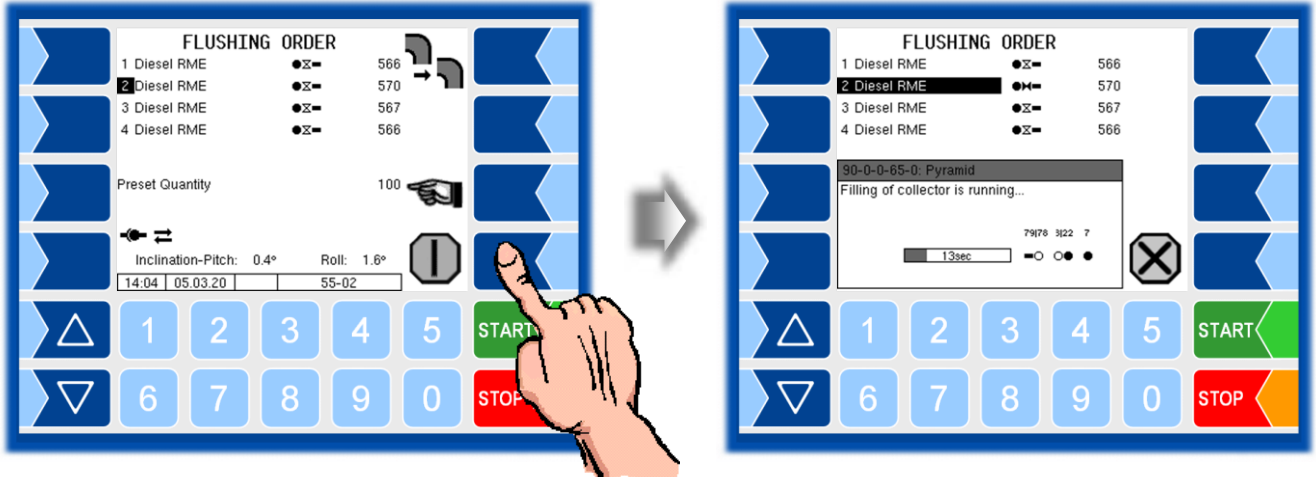

- Save the data of the flushing order at the end of the process and end the flushing order.

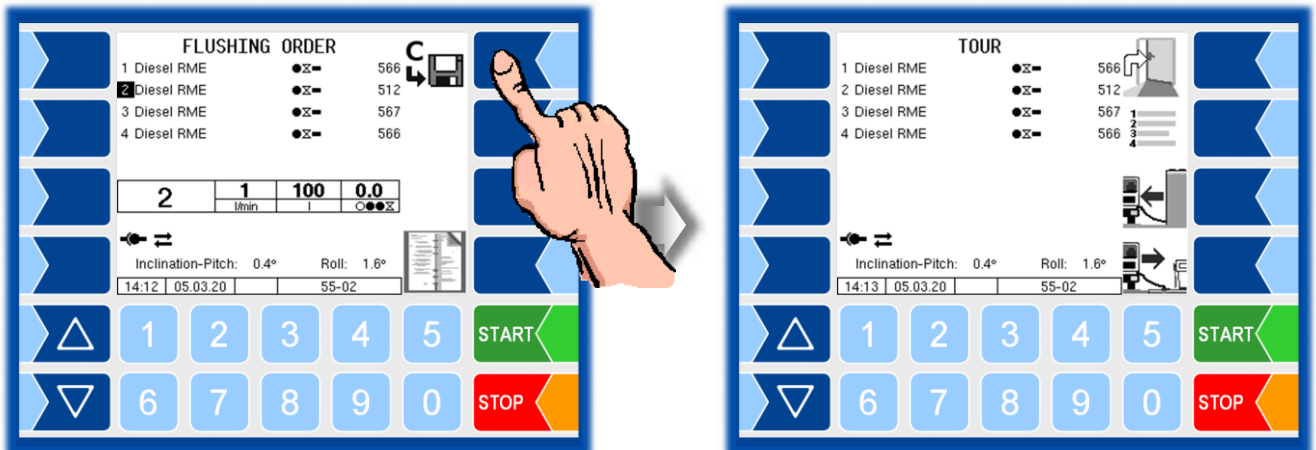

6.13 Flush Wet Hose to Trailer

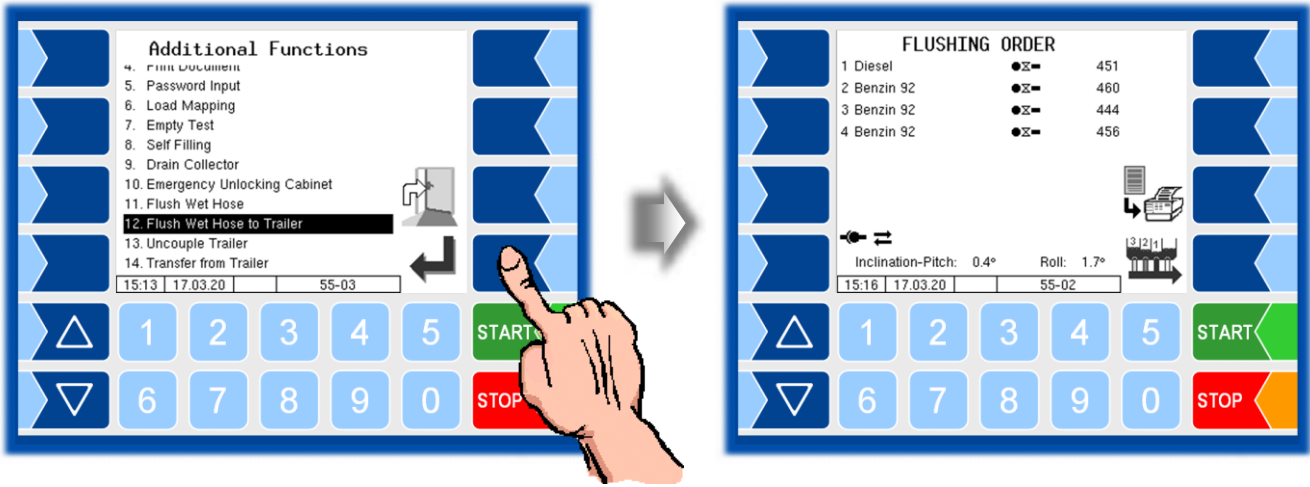

- Touch the collector delivery softkey and then select the hose to be flushed.

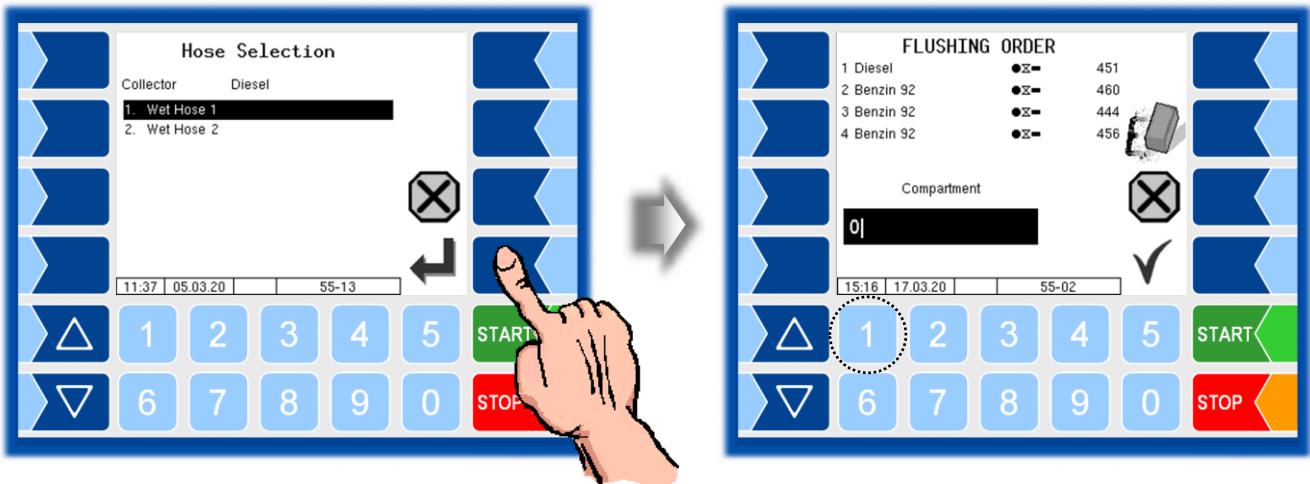
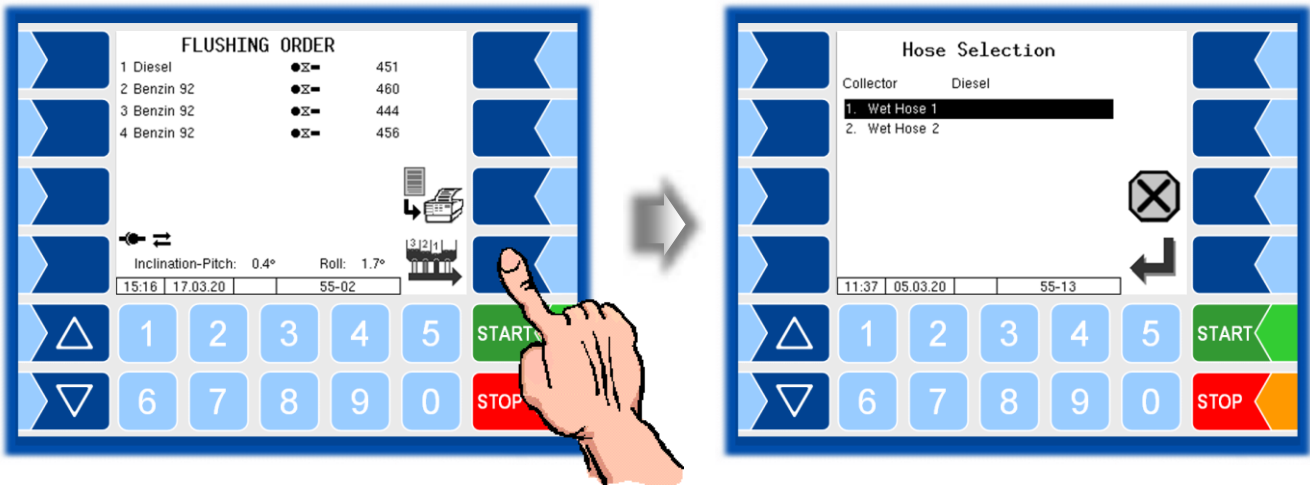

- Enter the number of the compartment from which the flushing product is to be taken.

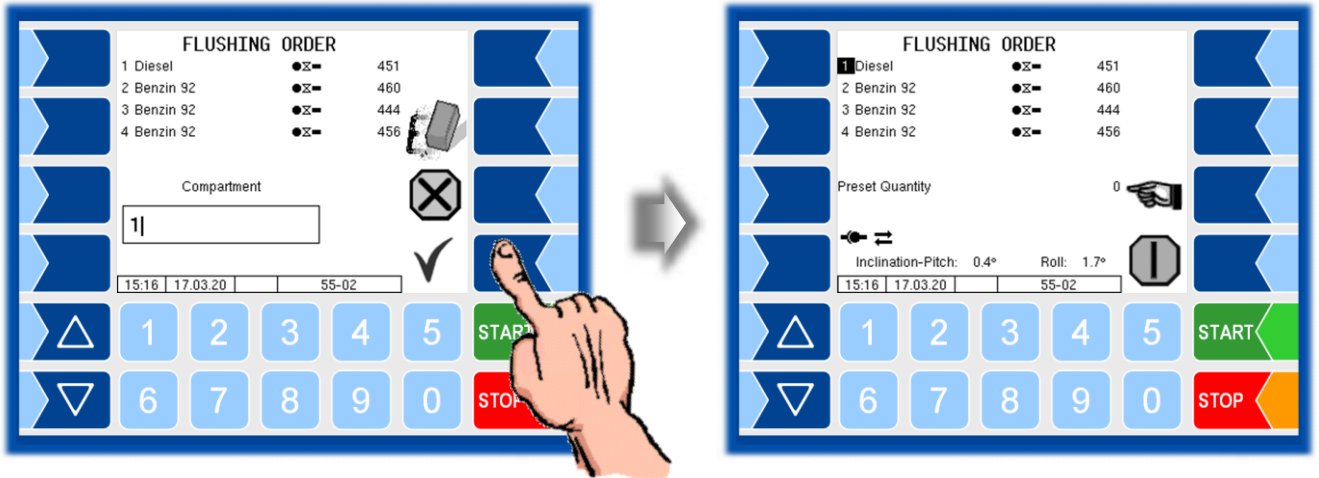

- Enter the quantity with which the hose should be flushed.



The flush volume must ensure that there is no longer any product from the previous delivery in the entire line.

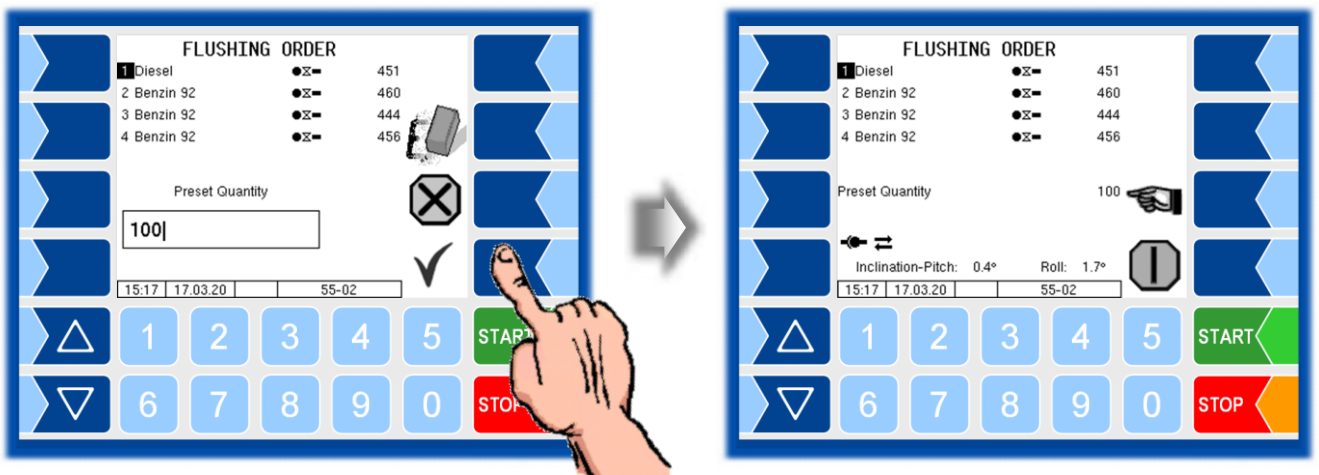
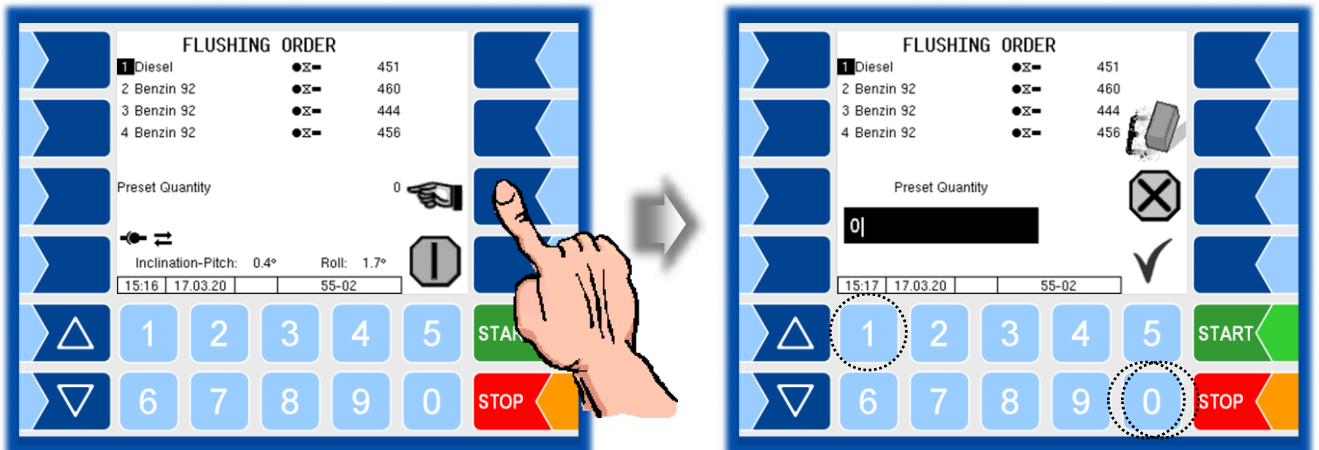

Make the connection of the hose to be flushed to the specified destination tank.



Follow the instructions from your company regarding the selection of the target tank for the flushing product.

- Start flushing with the "Start delivery" softkey".

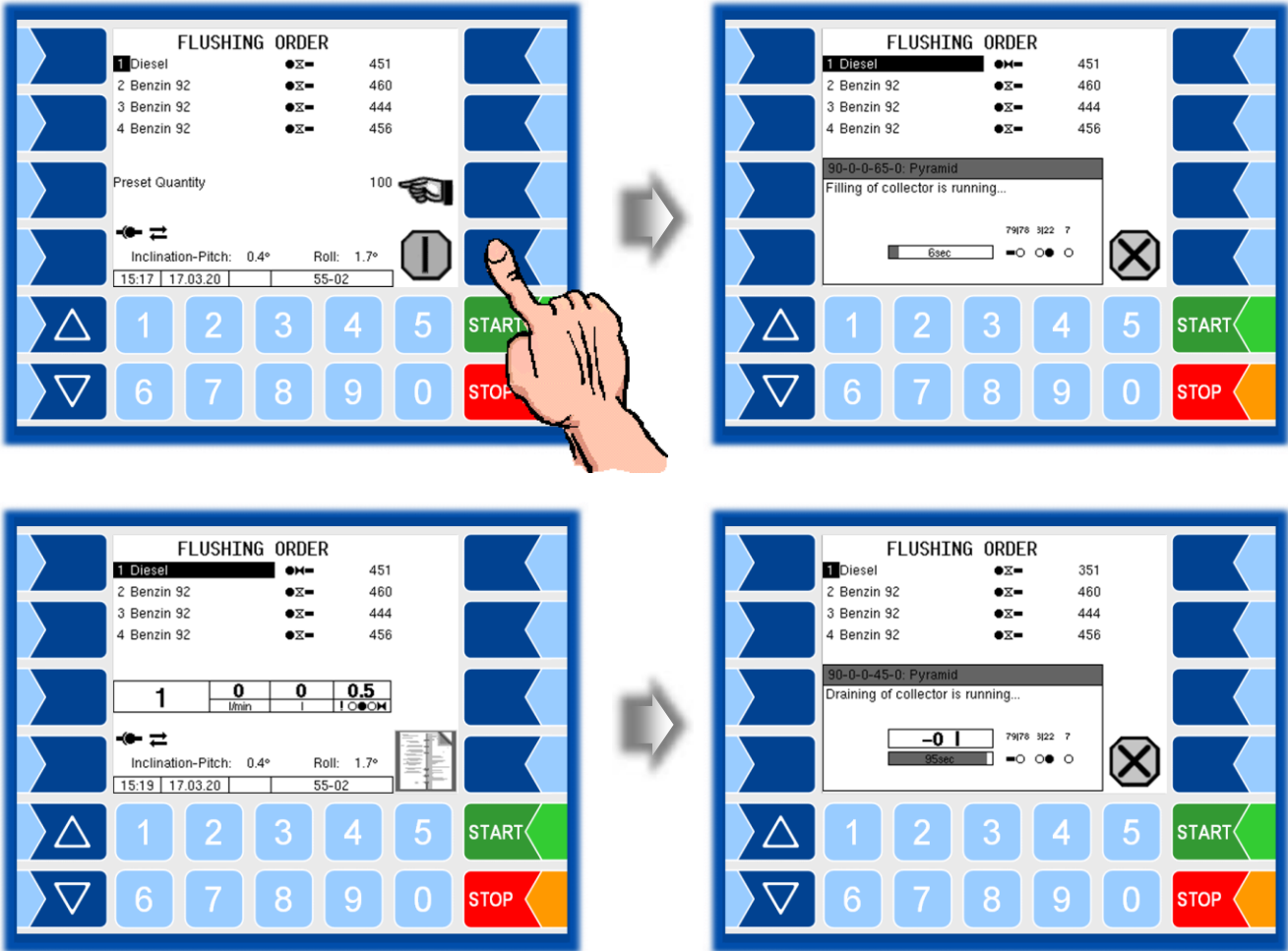

- Save the data of the flushing order at the end of the process and end the flushing order.

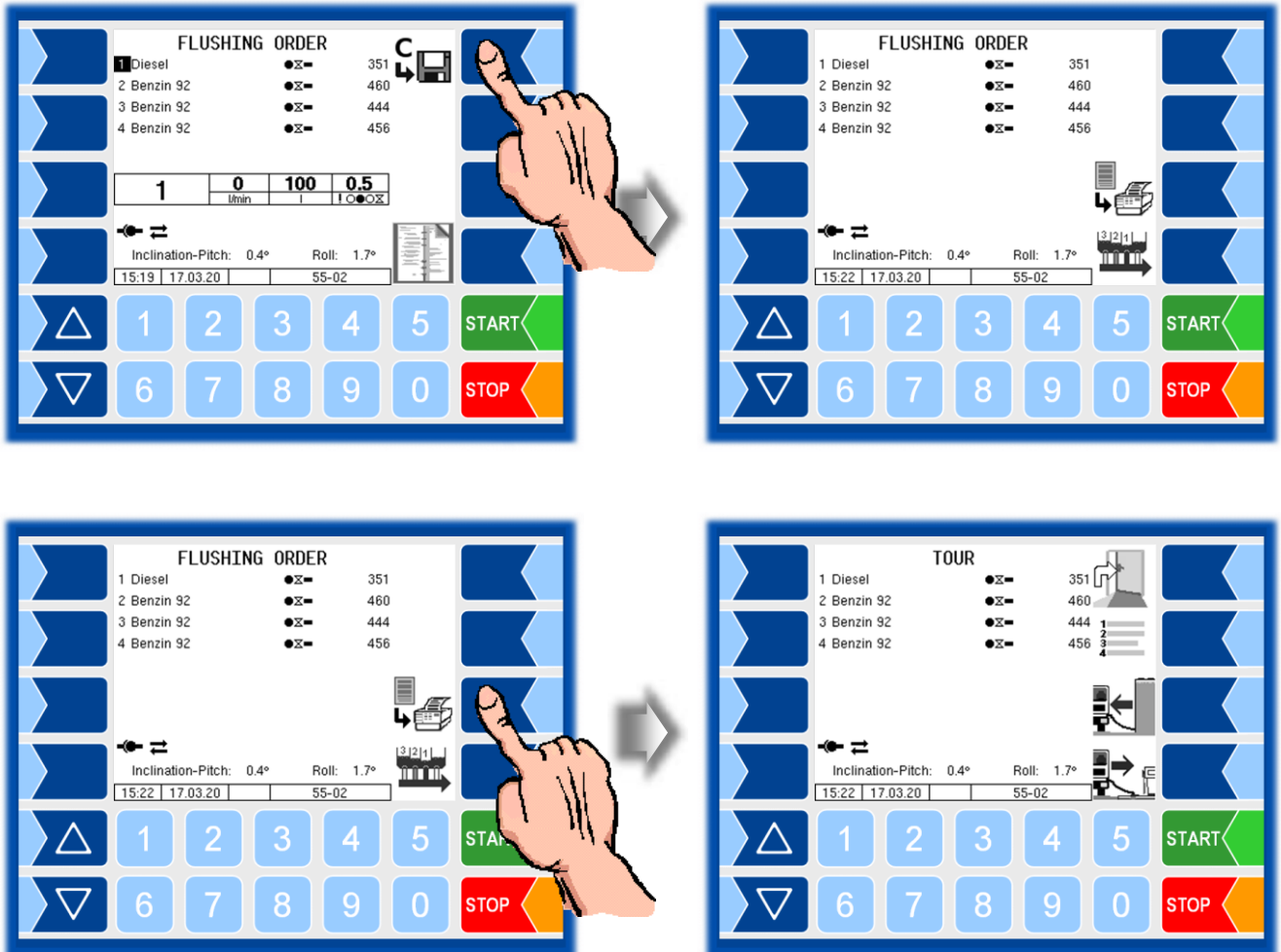

6.14 Emergency Load

This menu item is only available if a defect occurs on a hardware component that would not allow loading.

In this case, you can load unmeasured bypassing this hardware.

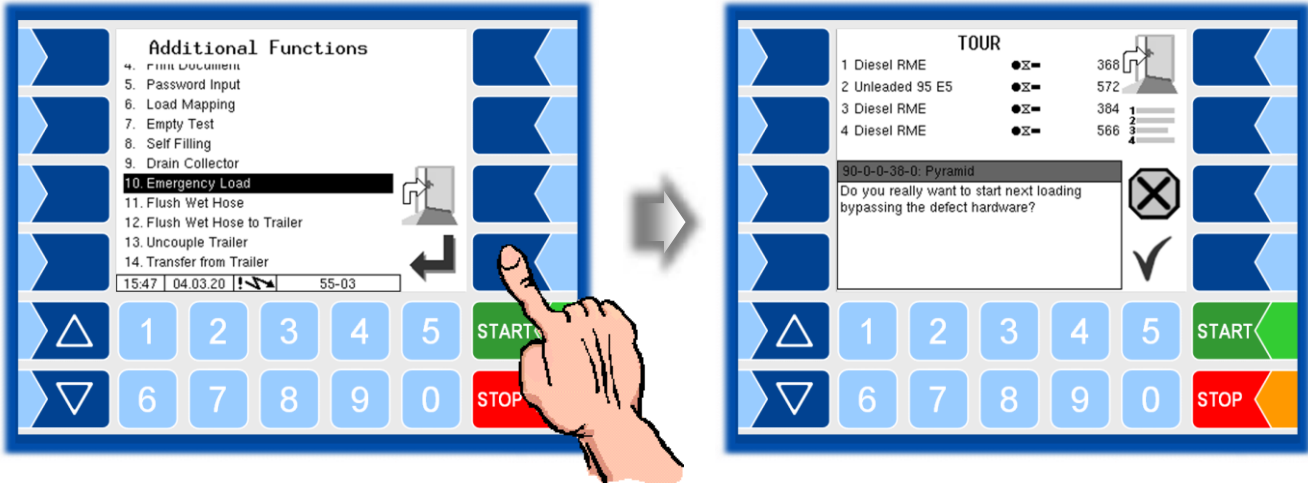

6.15 Delivery from the trailer via the truck counter

This function is only available on the trailer if logic output 11 (delivery via counter truck) is configured. It is used to record pumped deliveries from the trailer via the truck counter.

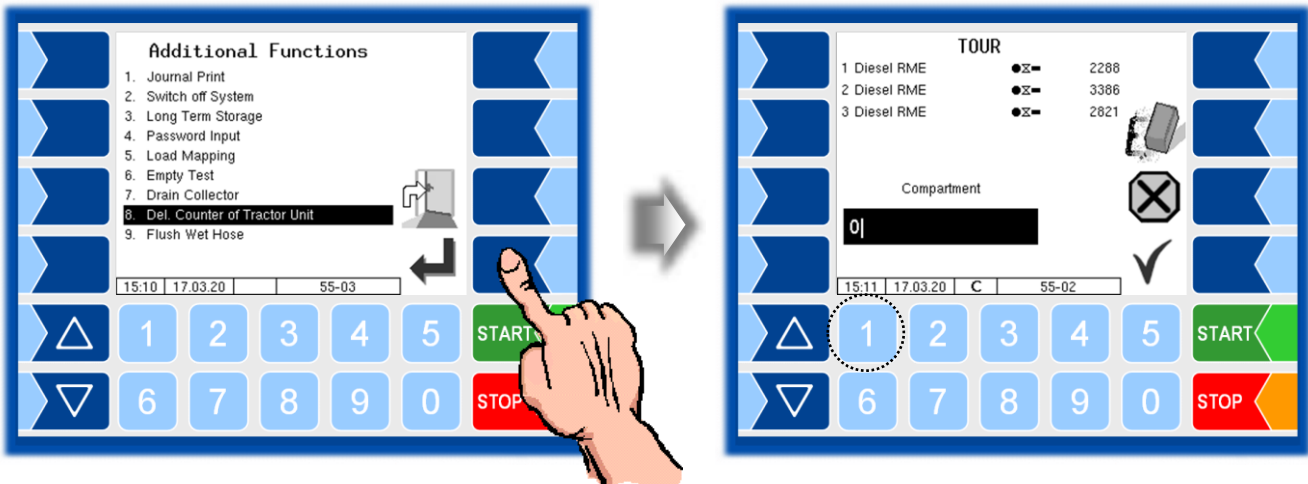

- Enter the number of the compartment from which the delivery is to be made.

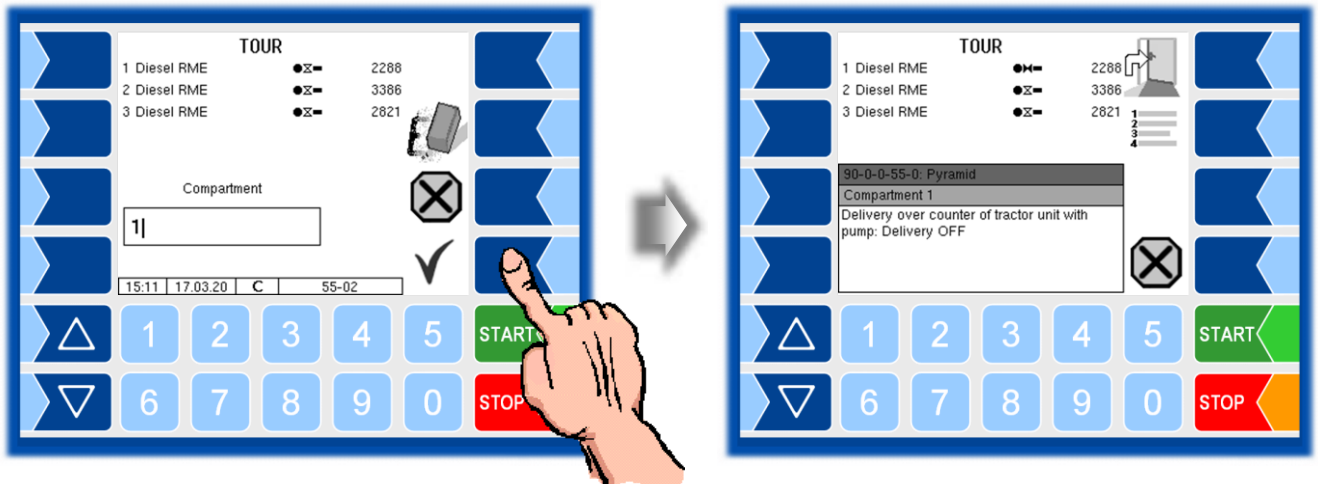

- Touch the **START** button to start the pump.

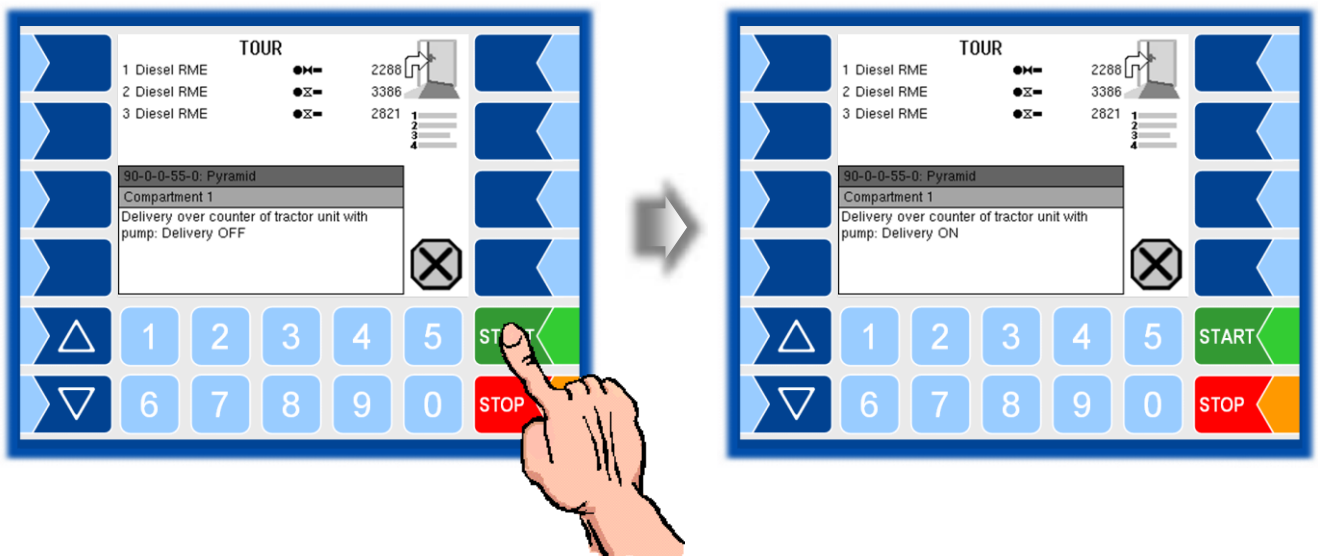

- To stop the delivery from the trailer, stop the pump with the **STOP** button.
- Then finish the "delivery via counter truck" function with the "Abord" softkey.

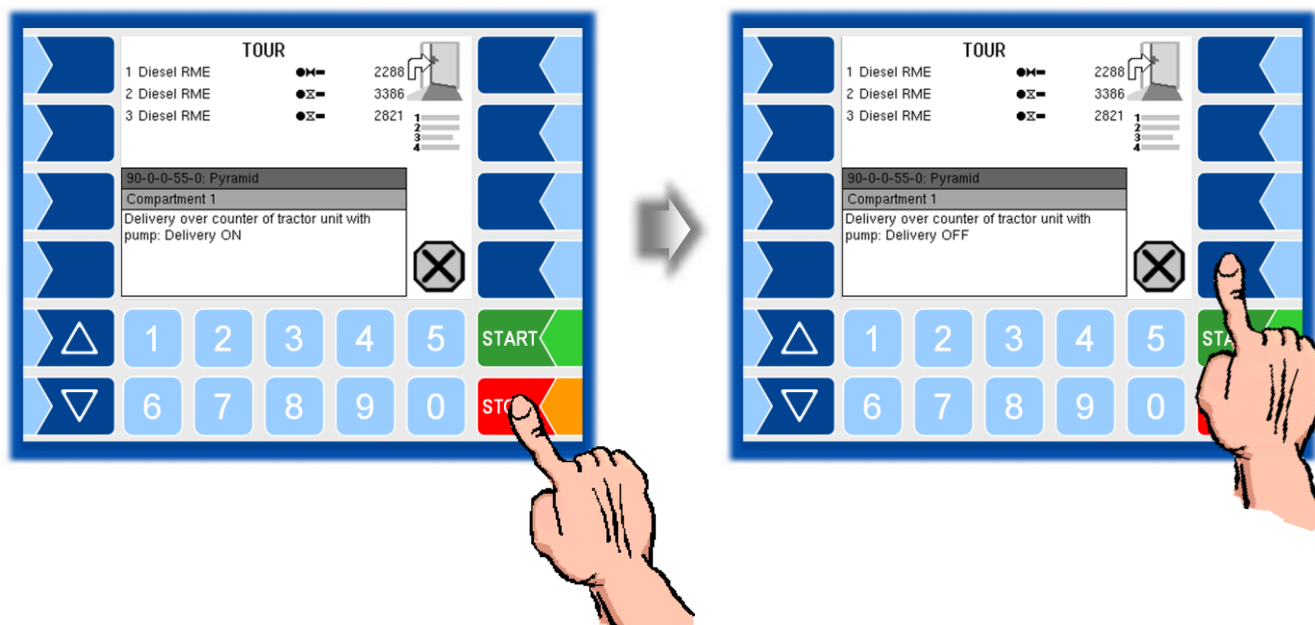

6.16 Emergency Unlocking Cabinet

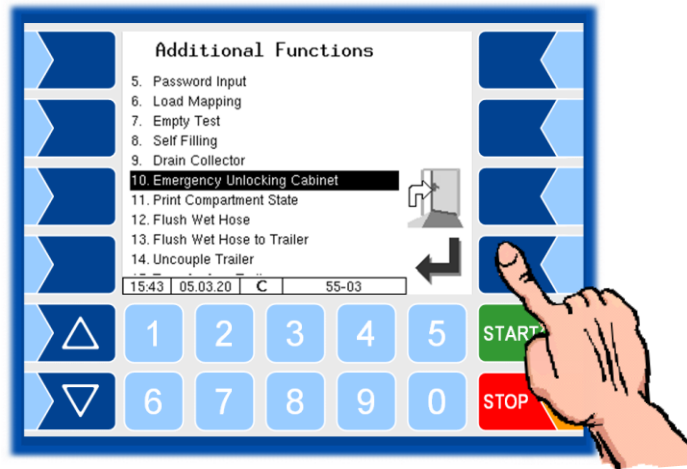

The cabinet doors are unlocked via output 12 "Cabinet door release" if customer data has been found for the current GPS coordinates.

If no position can be determined based on GPS data (GPS defective or not configured) or no GPS coordinates are saved for the current location, or if an unplanned delivery is to be started for other reasons, the cabinet door can only be opened after emergency unlocking.



An unplanned order is only possible after an emergency unlocking.

When unlocking, a 15-minute timer starts, during which the doors remain unlocked. After this time, the doors are locked again when they are closed. The emergency release is recorded.



An emergency unlocking is not required if the search radius of the GPS receiver is set to 0.

6.17

Print Compartment State



Available when the licensed option **SPDS 3003** or **SPDS 3003 Stand alone** is enabled.

The current compartment status is printed.

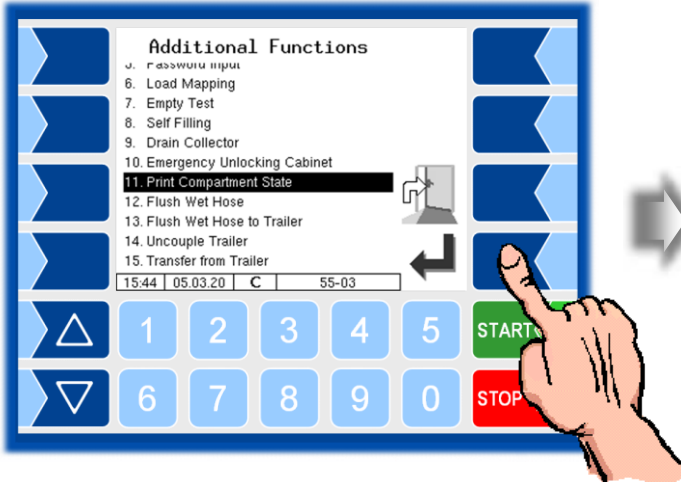

```

Status
Tourno :-- int.Tourno:25
Start  :29.09.15 11:39:26
Driver :i1
Truck  :i1 REG-EN 123
29.09.15
12:23 Status 1 Loaded
Diesel
sealed
12:23 Status 2 Loaded
Benzin bleifrei
sealed
12:23 Status 3 Loaded
Super bleifrei
sealed

```

Example Compartment State

6.18

Couple / Uncouple Trailer

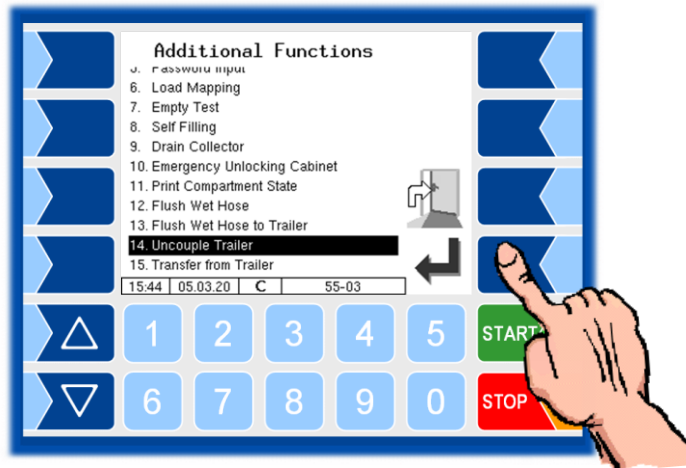

For operation with a trailer, this is registered or deregistered here. The symbols for trailer operation are displayed in the start window (see section 3.2.4).



In order to ensure a regulated system operation, the trailer must be registered or deregistered here, depending on whether the vehicle is to be operated with or without a trailer.

6.19 Transfer from Trailer

If required, products can be pumped from the trailer into the truck.

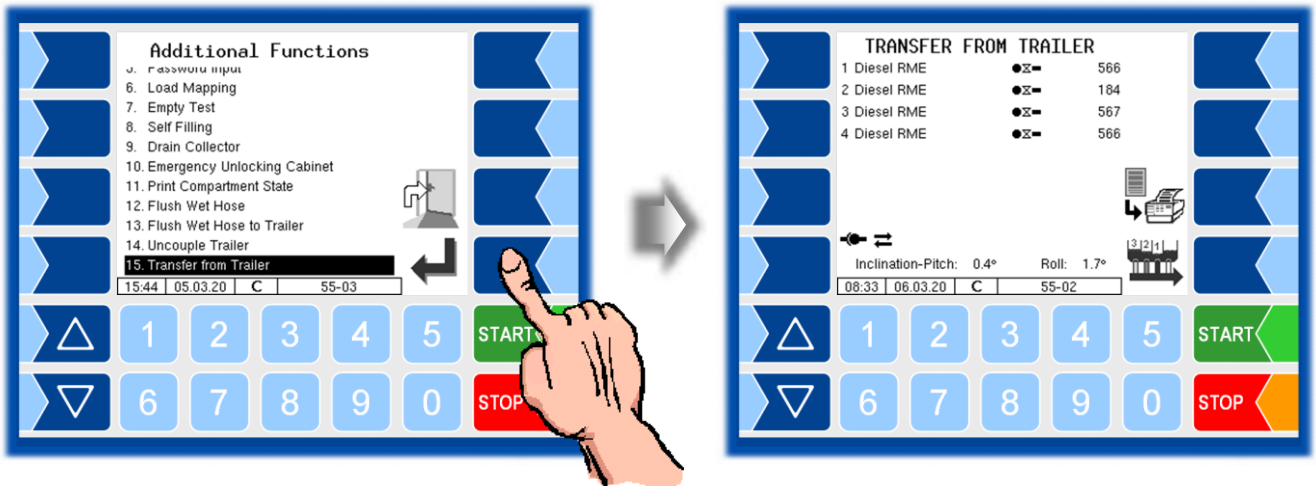

- Touch the collector delivery softkey.
- Enter the number of the compartment in the trailer from which the product is to be pumped.

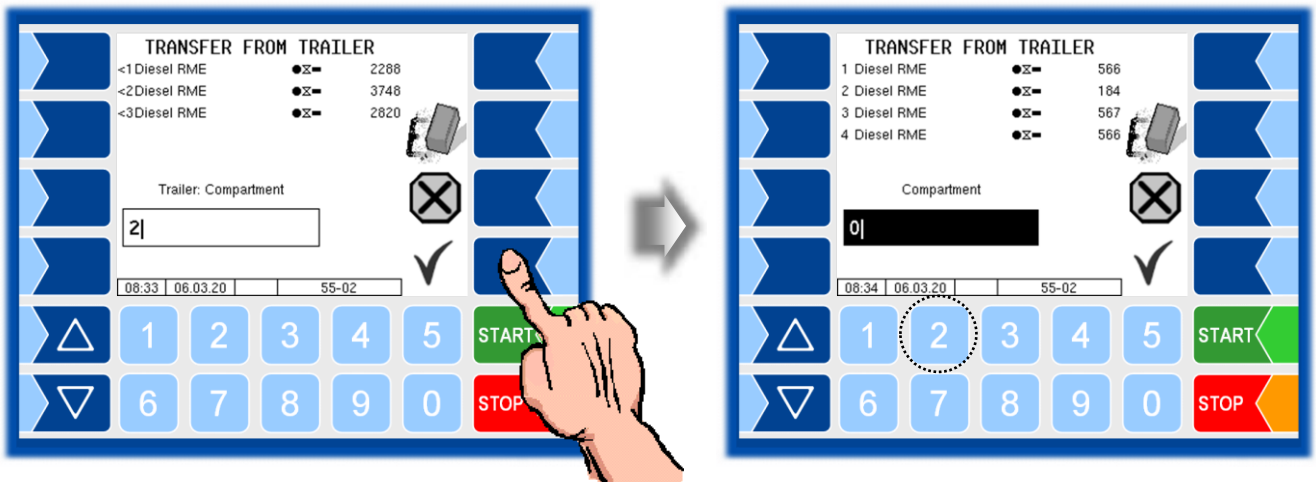
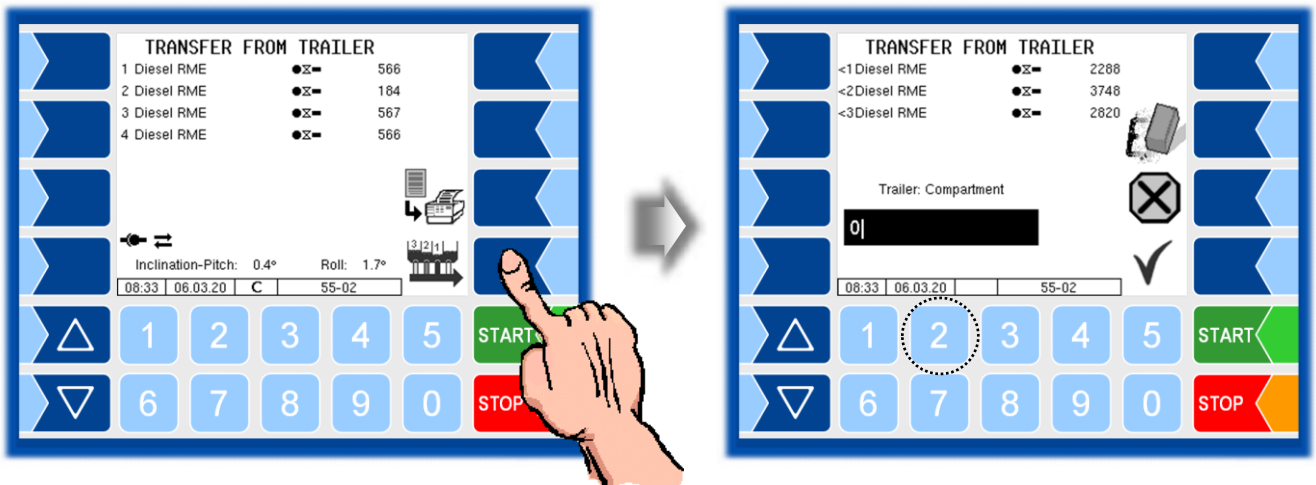

- Then enter the number of the compartment in the truck, that is supposed to receive the product.

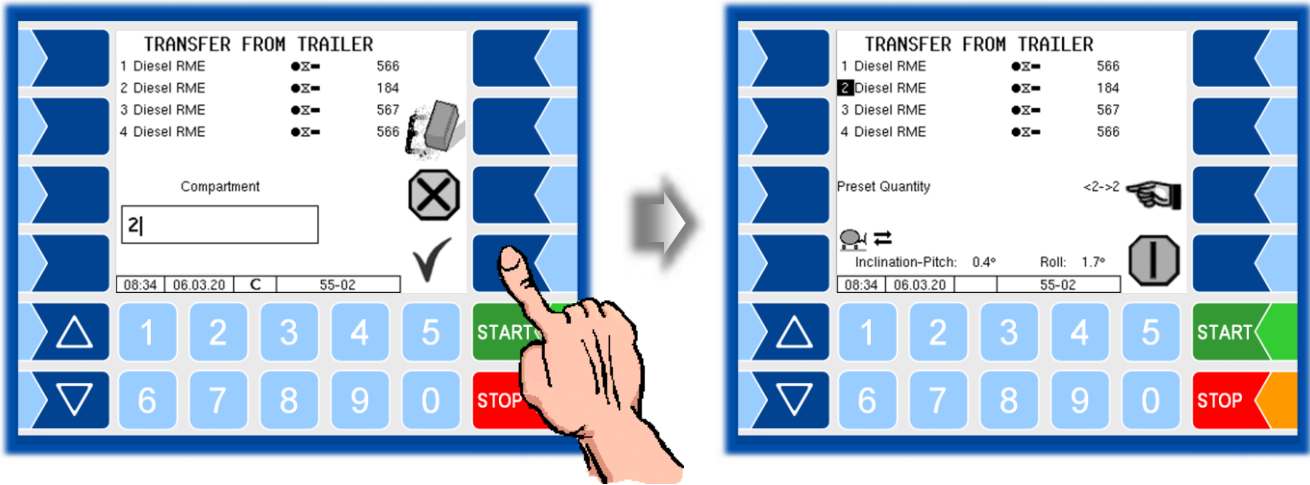

- Enter the quantity to be pumped over.

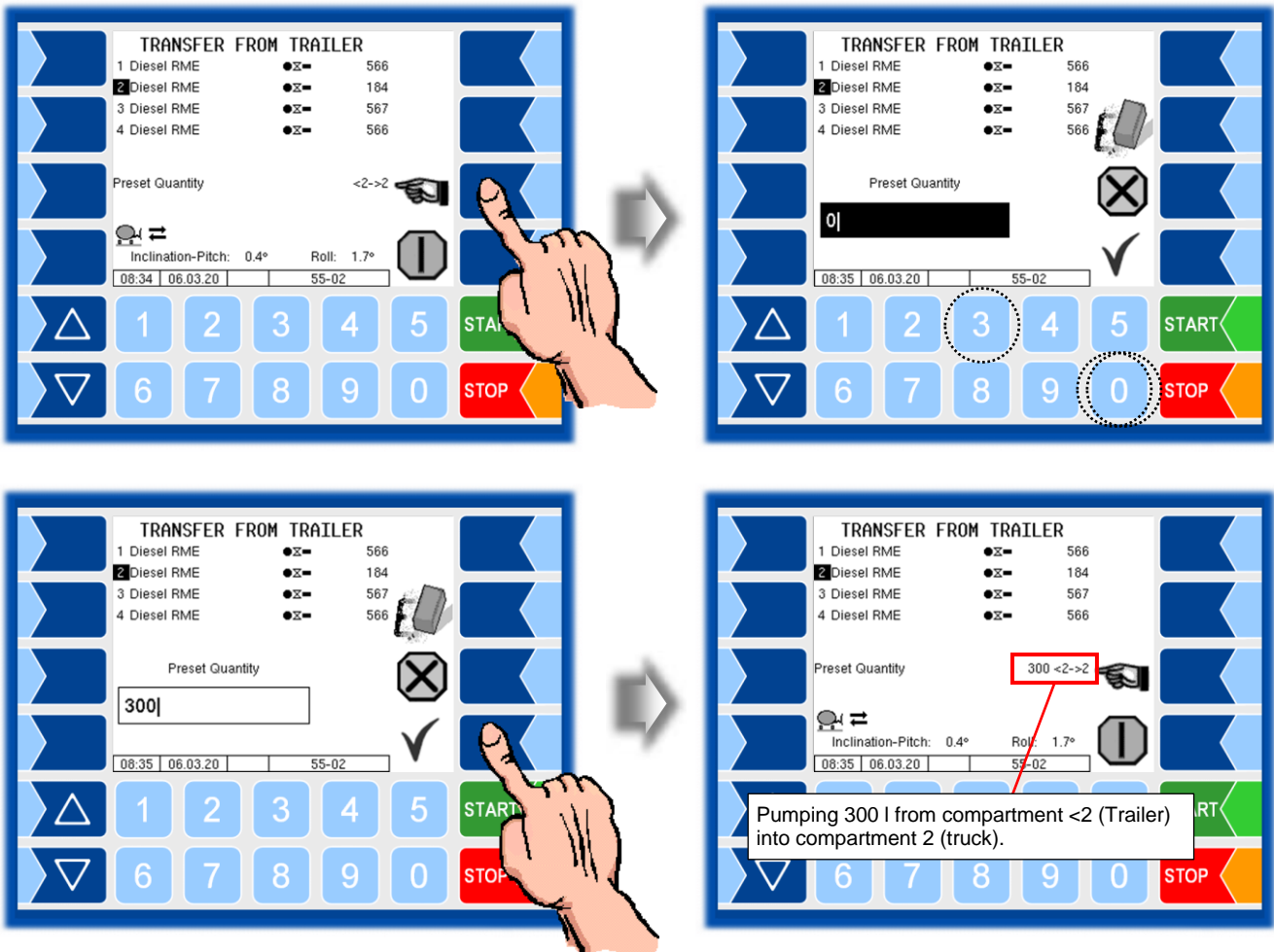

- Start pumping with the "Start delivery" softkey“.

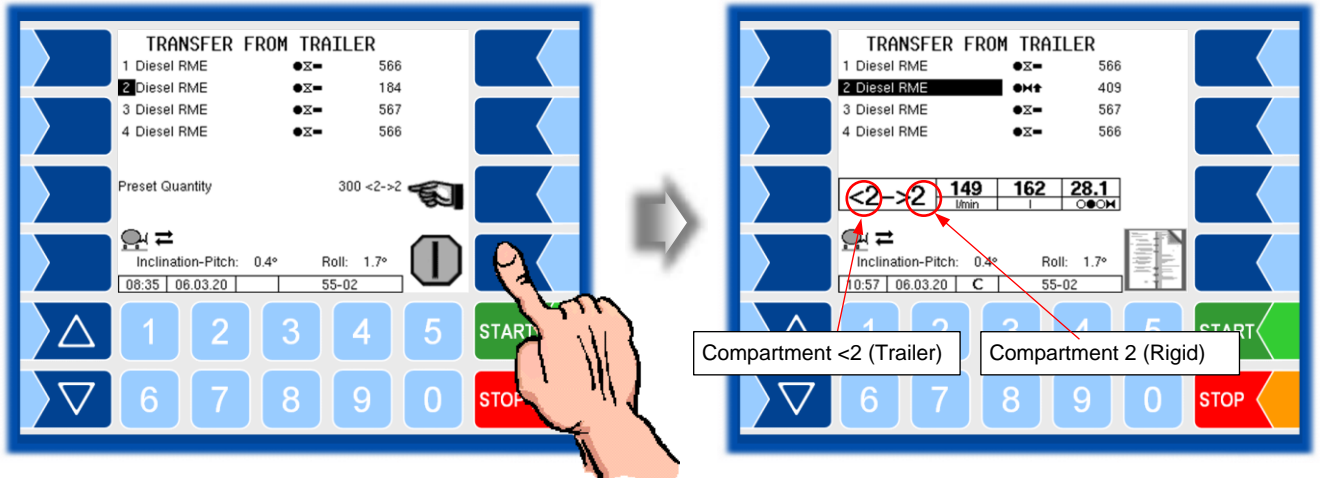

When the specified quantity has been pumped over, the process stops.

- Save the pumping data.

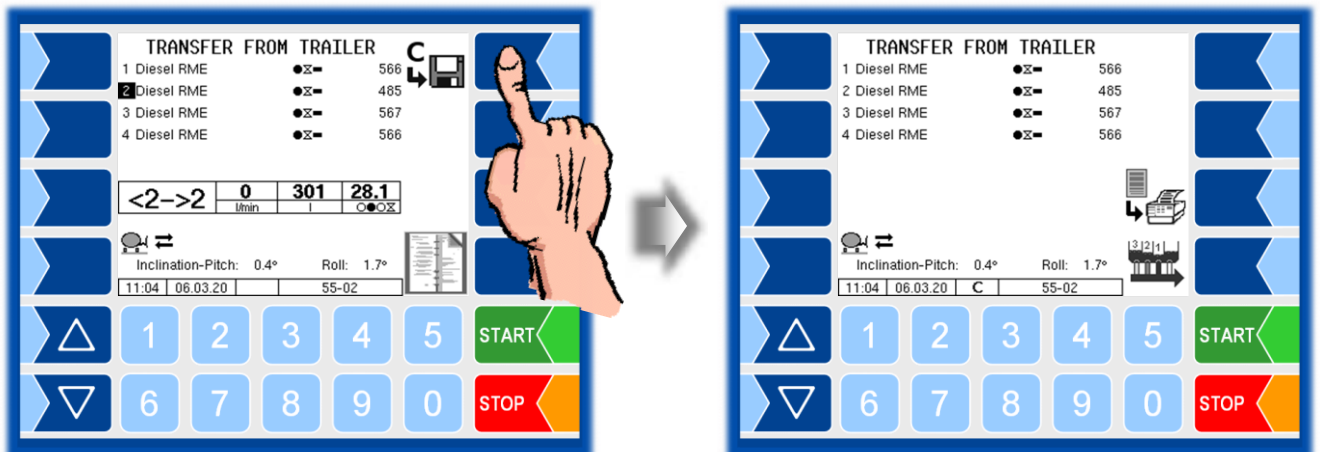

- End the pumping order.

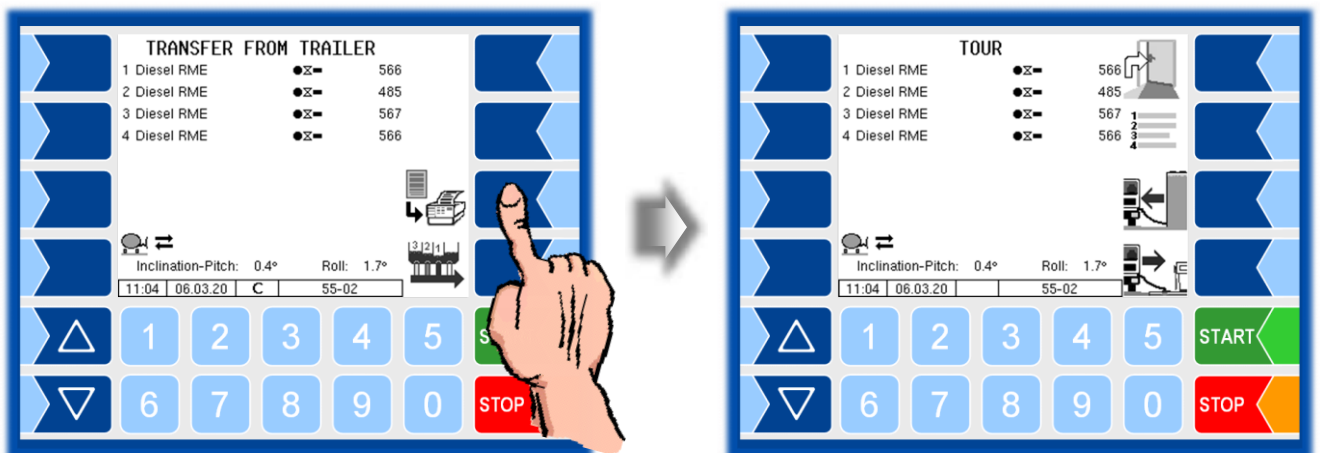

7 System monitoring

The measuring system is constantly monitored for reliability and fulfilment of the quality criteria.

7.1 Display of malfunctions

All operating statuses and results that are connected to safety and product quality are shown on the display in plain text and must be acknowledged by the operator.

Examples

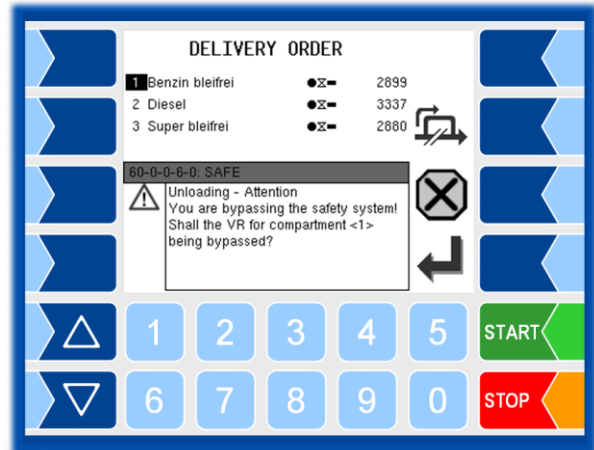
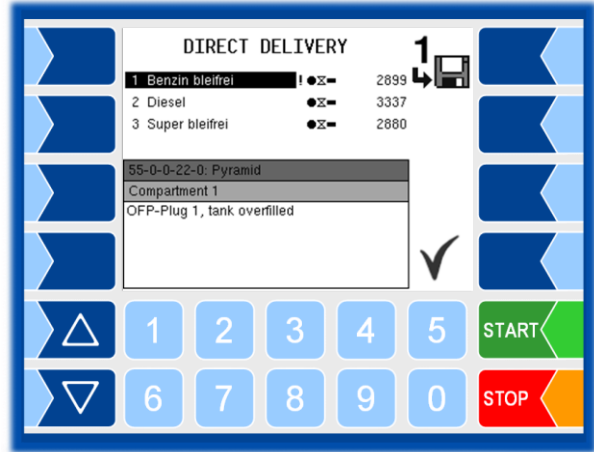
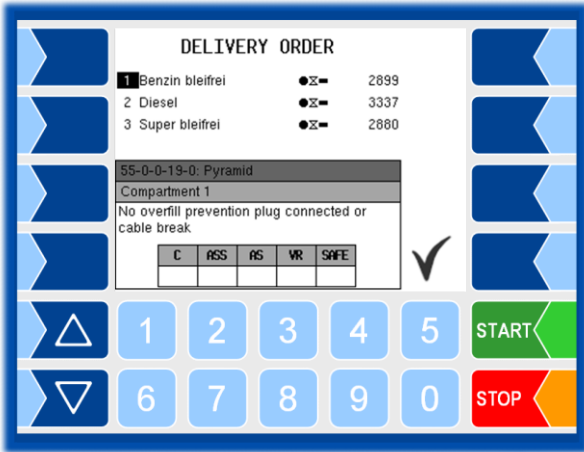
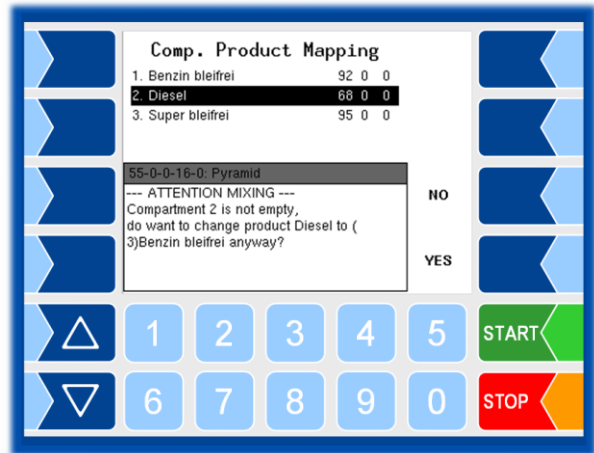
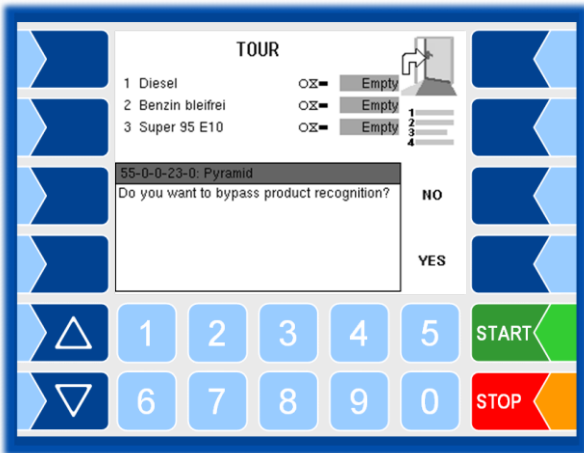

If an error occurs during an active delivery, causing this delivery to be interrupted, the event display window containing the relevant error message appears for 20 seconds.

You use the ✓ softkey to acknowledge messages that are displayed in this window. The “Events” window is automatically closed after 20 seconds.

The error symbol is then displayed in the information line as long as the error is still present.

For more information on an error displayed in the information line, you can open the event display manually.

Error messages are not cleared until the cause of the error has been removed. As long as the error is still active, an exclamation mark is displayed next to the error message.

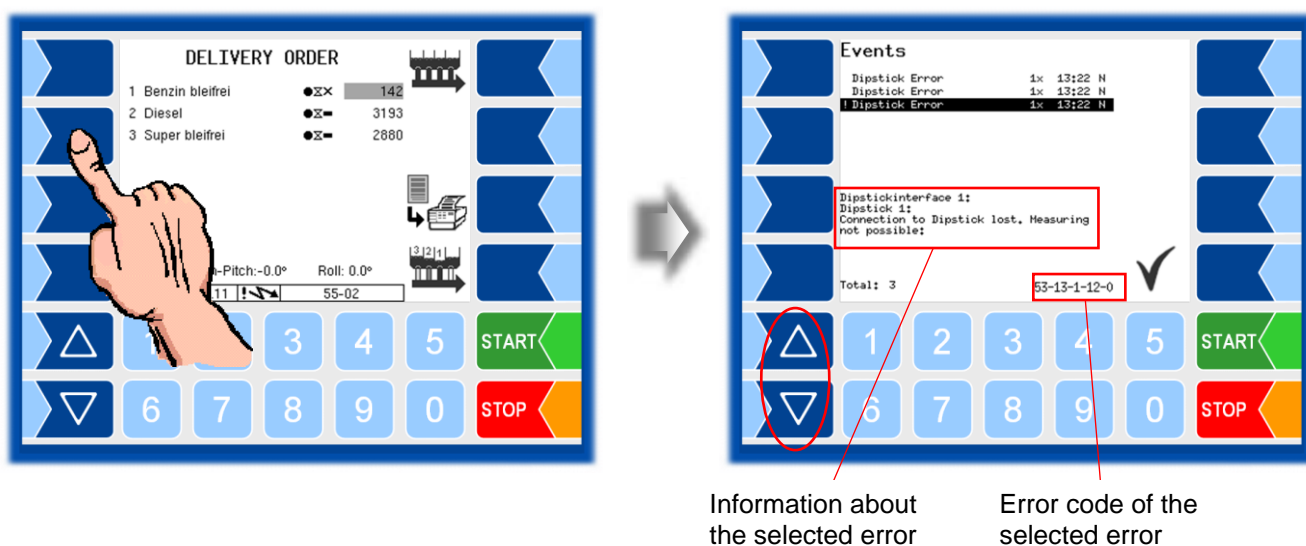

Maybe in the event display more than one error are displayed. Use the arrow-keys to select the individual messages

If you request help with an error from your service centre, you must enter the five numbers that are displayed at the bottom right of the Events window. These help the service center to pinpoint the error.

In order to note several error codes you have to select the individual messages with the arrow keys.



If the seal switch is open, the event display does not appear for 20 seconds if an error occurs. In this case, you must open the event display manually.

If an error occurs which prohibits a calibrated or compensated measurement, the delivery can only take place as an uncalibrated or uncompensated delivery.

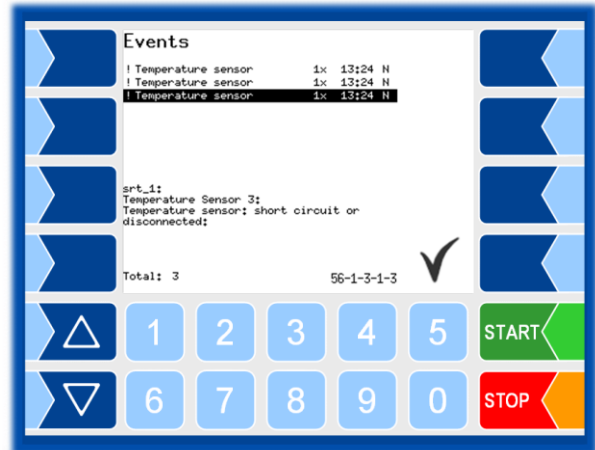

If an error occurs which prohibits a measured delivery, the bottom valve is closed and the delivery thus stopped. In this case, the delivery can not be continued.

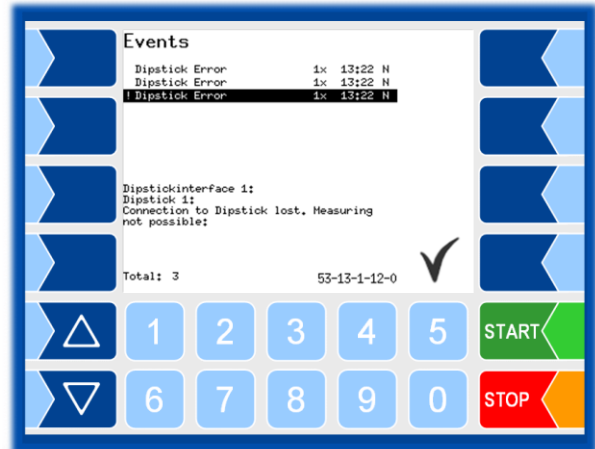

7.2 Attention monitoring

Attention monitoring can be configured to increase safety during operation. It is checked whether actions are carried out on the measuring system within certain time intervals.

Monitoring takes place as long as an order is being processed.

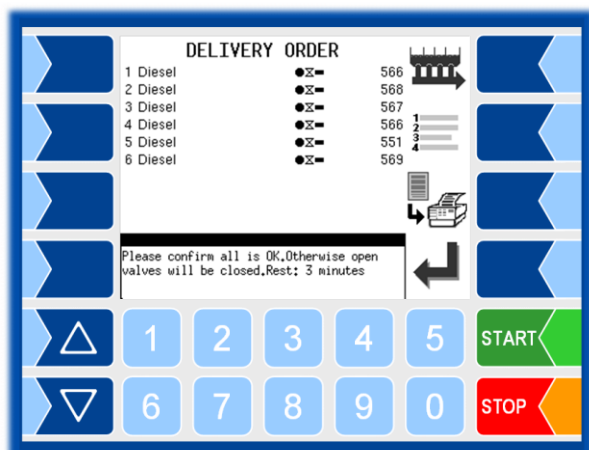

E.g. If the system is not operated within 25 minutes (*), a small notification window appears on the display.

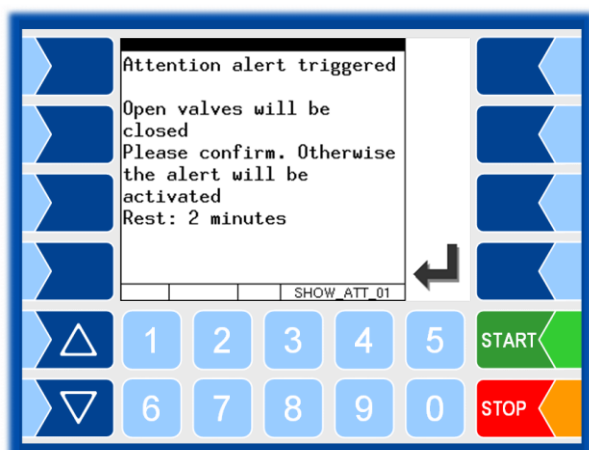

If no operation is found after further 5 minutes (*), a large notification window is displayed. If a delivery is in progress, it will be stopped.

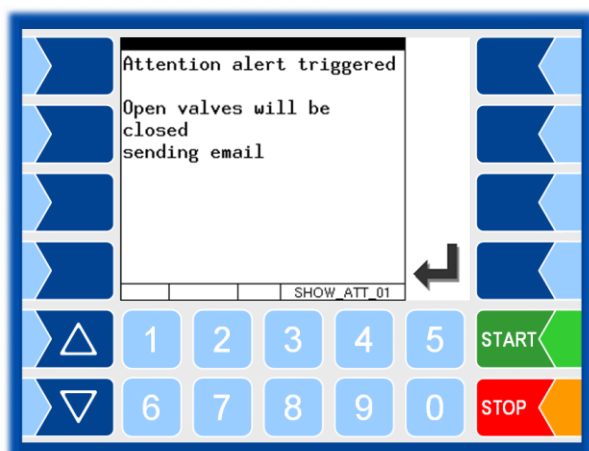

If no operation takes place after further 2 minutes (*), an e-mail is sent to a specified address and output 101 is activated if this is configured.

(*) The specified values are default settings for configurable times).

7.3 Alarm trigger device

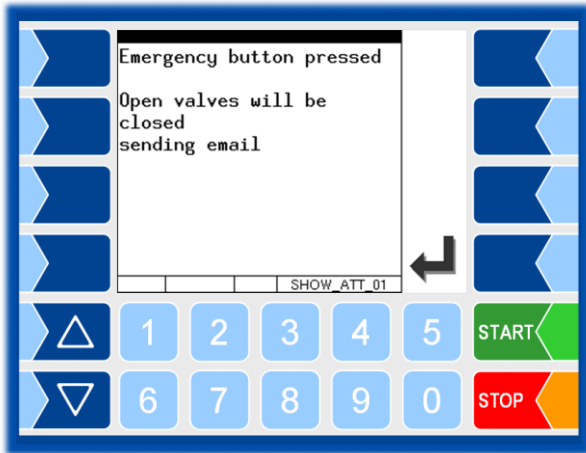

An alarm trigger device (emergency button) can be installed independently of the attention monitoring. When activated, current deliveries are stopped, an e-mail is sent to a specified address and output 101 is activated if this is configured.

7.4 Emergency delivery



If there is a defect in a hardware component when starting an order that would not allow a measured delivery, the "Emergency delivery" softkey is available. In this case you can do the following delivery bypassing the defective hardware.

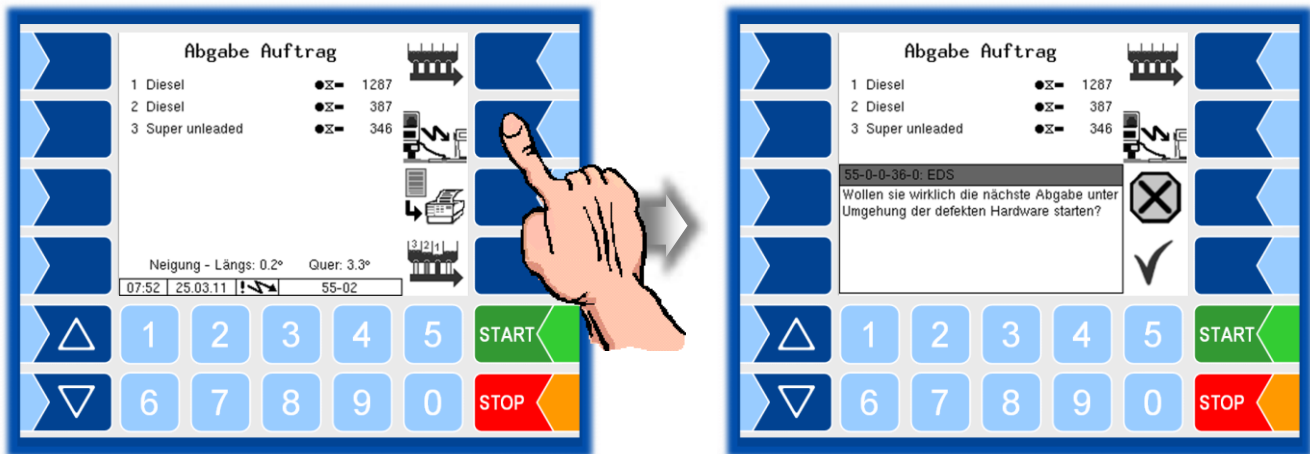

7.5 Cabinet door monitoring

Vehicles that can be operated from both sides can optionally be equipped with a cabinet door monitoring.

When starting the order, the cabinet door on the side on which delivery should take place must be opened.

If no cabinet door monitoring is installed or if there is a defect, the delivery side can be selected manually.

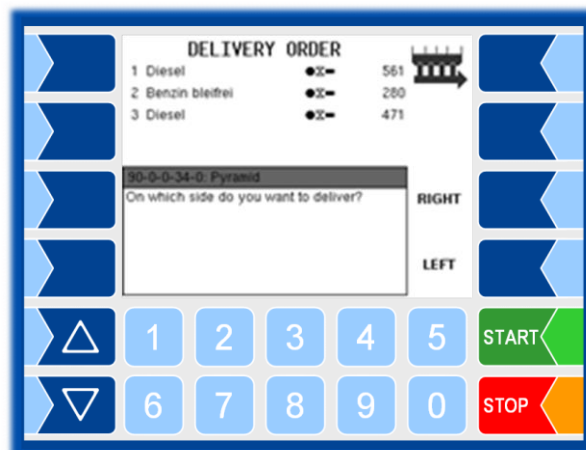

If both sides are opened (with cabinet door monitoring), delivery can only take place after the door has been closed on one side. In this case, a running delivery is interrupted and can only be continued after one cabinet flap has been closed.

The cabinet doors are not monitored during loading.

Instructions for operation with installed cabinet door monitoring are shown in plain text on the display.

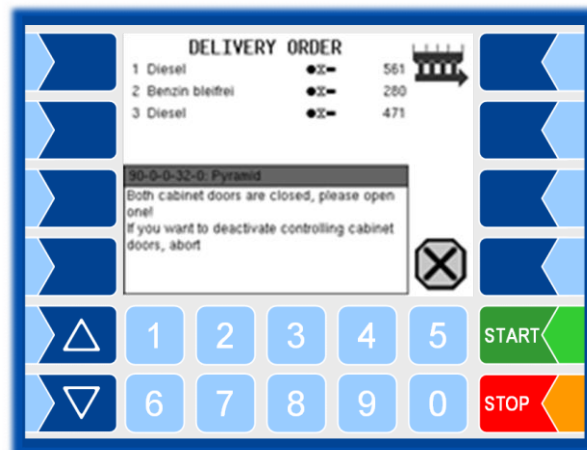

Bypassing (deactivating) the cabinet door monitoring is logged and printed out in the journal.

7.6 Diagnostics menu

You can use the upper left softkey to open a diagnostics menu. This service function allows the service professionals to perform a specific diagnosis on individual system components.

You can open the diagnostic menu either outside of a tour, within a tour or within an order.



Use the functions of the diagnostic menu only when instructed to do so and in cooperation with trained service personnel!

More detailed information on the various diagnostic options can be found in the configuration instructions for the PETRO 3003 system.

