



ELEKTROMOTORJI V PROTIEKSPLOZIJSKI ZAŠČITI

MOTEURS ANTIDÉFLAGRANTS

SQUIRREL - CAGE MOTORS

DRUCKFESTGEKAPSELTE MOTOREN



II 2G Ex db II(B)C T* Gb



II 2G Ex db eb II(B)C T* Gb



II 2D Ex tb IIIC T* °C Db

4KT(B)C(D) 71 – 132

4KT(B)C(D) 71 IE3 – 132 IE3



3 – 5	REZERVNI DELI (RISBE) 4KTC71, 4KTC 80-132 ERSATZTEILE 4KTC 71, 4KTC 80-132 SPARE PARTS 4KTC 71, 4KTC 80-132
6 – 15	SEZNAM REZERVNIH DELOV ERSATZTEILLISTE PARTS LIST
16 – 21	NAVODILA ZA MONTAŽO IN PRIKLJUČITEV
22 – 27	INSTALLATION GUIDELINES FOR SQUIRREL-CAGE MOTORS
28 – 33	AUFSTELLUNGSRICHTLINIEN FÜR DRUCKFESTGEKAPSELTE MOTOREN
34	DVIŽNA MESTA ZA PRESTAVLJANJE HEBEVORRICHTUNG FÜR DEN TRANSPORT LIFTING POINTS FOR MOTOR LIFT
35	VEZNI NAČRT ANSCHLUSS SCHALTBILD CONNECTION DIAGRAMM
36 – 47	CERTIFIKAT O SKLADNOSTI BVS 13 ATEX E 125 X / IECEx BVS 13.0121X KONFORMITÄTSBESCHEINIGUNG BVS 13 ATEX E 125 X / IECEx BVS 13.0121 X CERTIFICATE OF CONFORMITY BVS 13 ATEX E 125 X / IECEx BVS 13.0121 X
48	IZJAVA O SKLADNOSTI CE EG KONFORMITÄTSBESCHEINIGUNG EC CERTIFICATE OF CONFORMITY
49 – 50	RECIKLAŽA
51 – 52	RECYCLING
53 – 54	RECYCLING

REZERVNI DELI
SPARE PARTS-ERSATZTEILE
4KTC 71

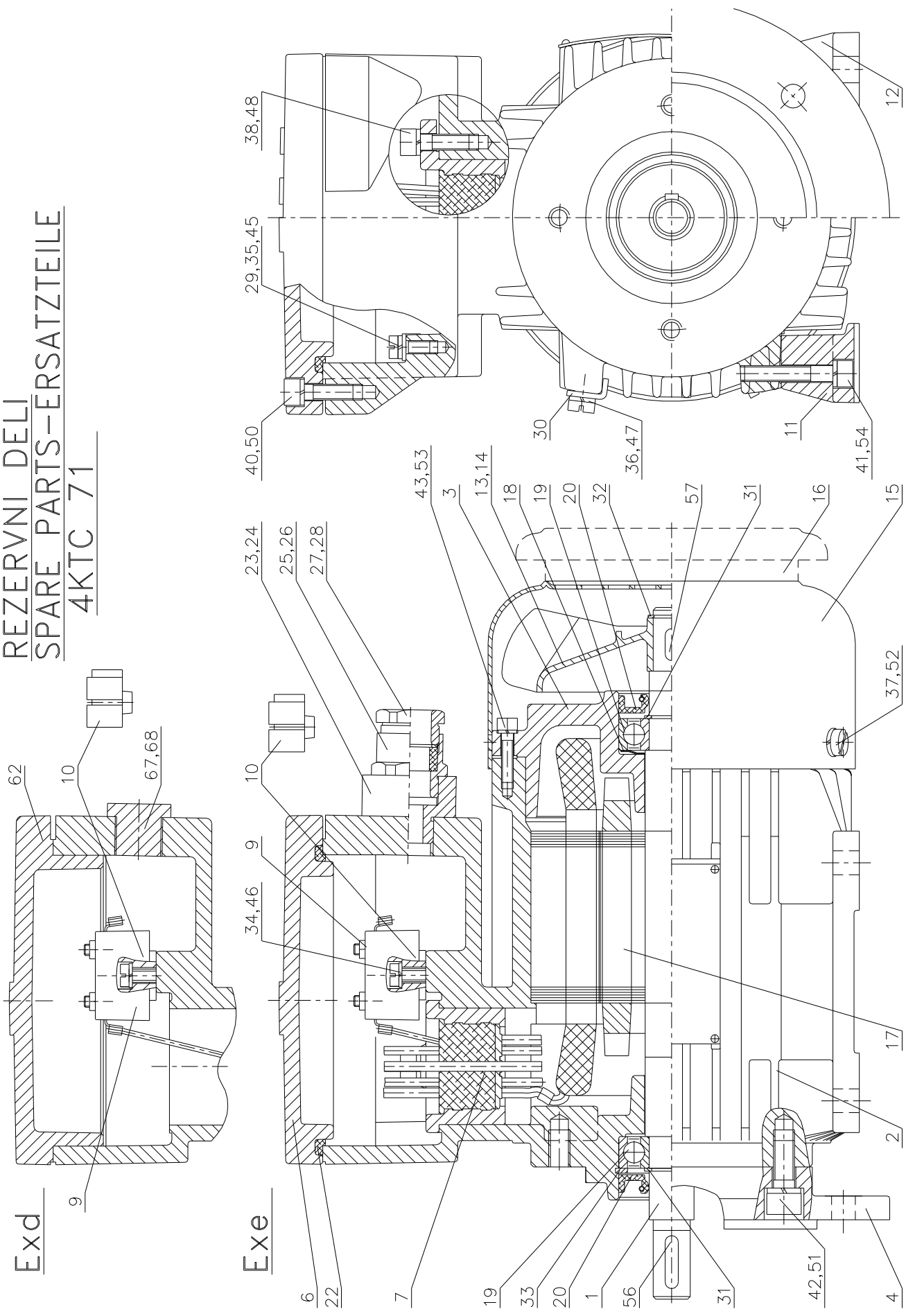

Exd

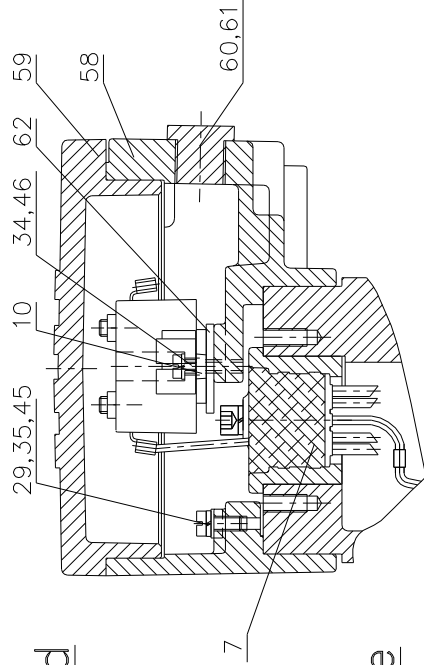

Exe

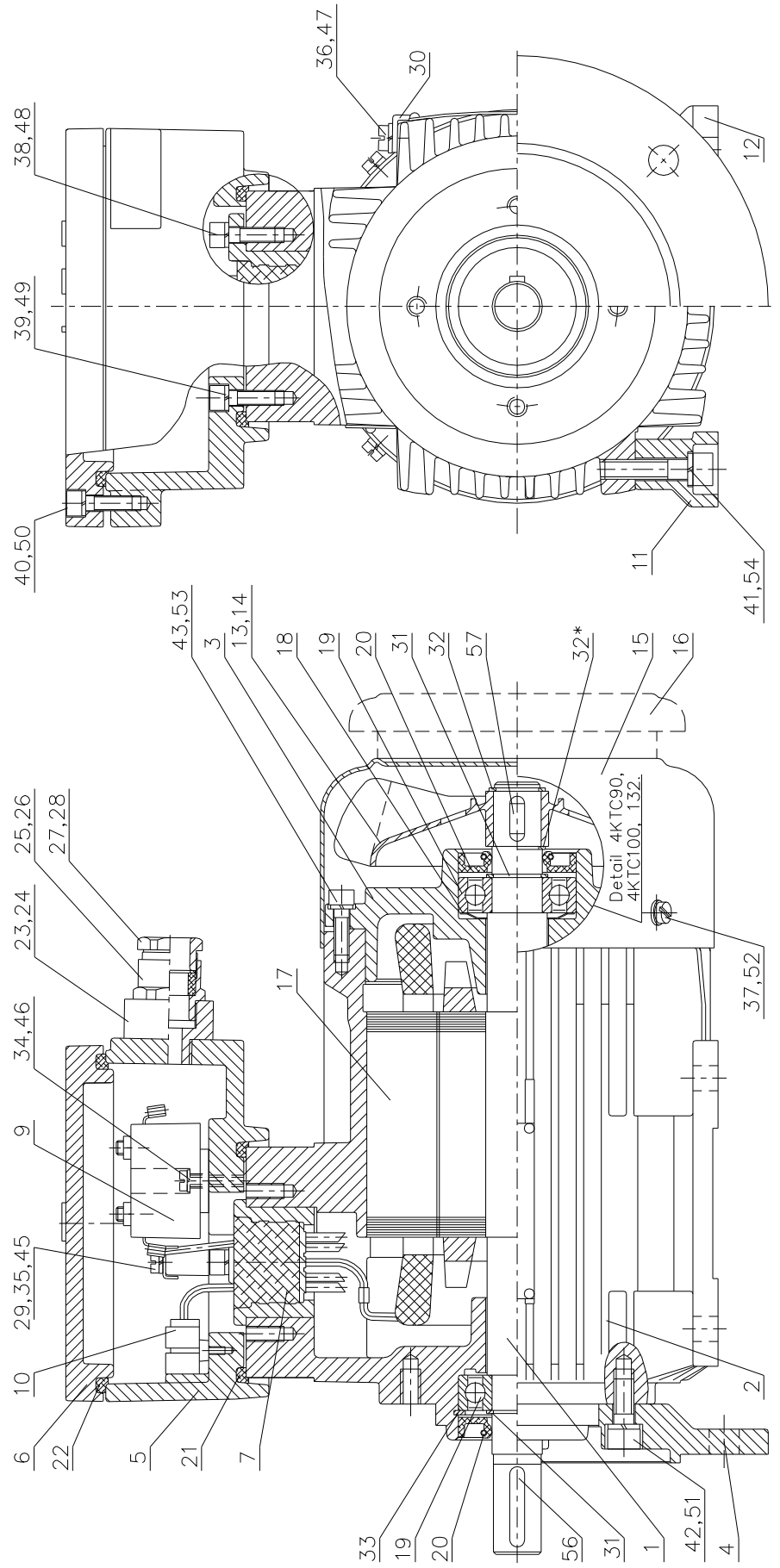

REZERVNI DELI
SPARE PARTS-ERSATZTEILE
4KTC80-132

OPOMBA- REMARK - BEMERKUNG

- *32 - motorji 80 in 112 so brez pozicije 32
- *32 - Internal clipping not fitted on size 80 and 112
- *32 - Baugrosse 80 und 112 ohne Innerer Sprengring

REZERVNI DELI
SPARE PARTS-ERSATZTEILE

Direktni uvod
Direct entry

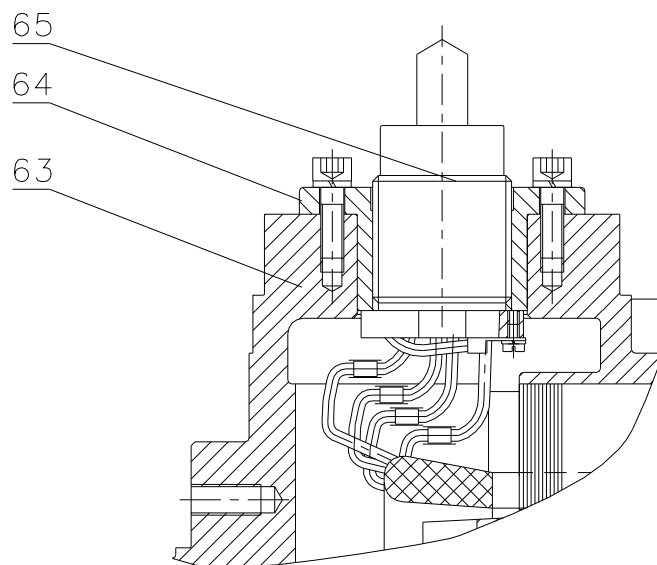

ITEM No.	PART No.	DENOMINATION	QUANTITY
POS. Nr.	ARTIKEL Nr.	BEZEICHNUNG	ANZAHL
POZICIJA	RAZPOZNAVNA ŠT.	IME	KOLIČINA

1.	SHAFT ROTOR UNIT	1
	LAÜFER	
	ROTOR	

		4KTC71	4KTC80	4KTC90	4KTC100	4KTC112	4KTC132
264875	A2	*					
264873	A4	*					
264877	A6,8	*					
264876	B2	*					
264874	B4	*					
264878	B6,8	*					
265046	A2		*				
265044	A4		*				
265048	A6,8		*				
265047	B2		*				
265045	B4		*				
265049	B6,8		*				
265273	L2			*			
265271	L4			*			
265275	L6,8			*			
265274	S2			*			
265272	S4			*			
265276	S6,8			*			
265457	L2				*		
265455	LA4				*		
265456	LB4				*		
265459	L6				*		
265459	LA8				*		
265458	LB8				*		
265632	M2					*	
265631	M4					*	
265633	M6,8					*	
265771	SA2						*
265770	SB2						*
265764	S4						*
265765	S6						*
265768	S8						*
265763	M4						*
265766	MA6						*
265767	MB6						*
265769	M8						*

2.	HOUSING	1
	GEHAUSE	
	OHIŠJE STATORJA	

	4KTC71	4KTC80	4KTC90	4KTC100	4KTC112	4KTC132
276194	*					
265008		*				
265238			*			
265422				*		
265608					*	
265724						*

ITEM No.	PART No.	DENOMINATION	QUANTITY
POS. Nr.	ARTIKEL Nr.	BEZEICHNUNG	ANZAHL
POZICIJA	RAZPOZNAVNA ŠT.	IME	KOLIČINA

3.	END SHILD	1
	LAGERSCHILD	
	STATORJEV ŠČIT	

	4KTC71	4KTC80	4KTC90	4KTC100	4KTC112	4KTC132
264883	*					
265054		*				
265281			*			
265465				*		
265638					*	
265773						*

4.	FLANGE STANDARD	1
	FLANSCH GENORMT	
	PRIROBNICA	

		4KTC71	4KTC80	4KTC90	4KTC100	4KTC112	4KTC132
264961	F130 I	*					
265131	F165 I		*	*			
265524	F215 I				*	*	
265853	F265 I						*
264962	F 85 II	*					
265134	F100 II		*				
265349	F115 II	*		*			
265132	F130 II		*	*			
265535	F165 II				*	*	
265537	F130 II				*	*	

5.	TERMINAL BOX Exe	1
	KLEMMENKASTEN Exe	
	PRIKLJUČNA OMARICA Exe	

	4KTC80	4KTC90	4KTC100	4KTC112	4KTC132
265036	*	*	*	*	*

6.	COVER Exe	1
	KLEMMENKASTENDECKEL Exe	
	POKROV PRIKLJUČNE OMARICE Exe	

	4KTC71	4KTC80	4KTC90	4KTC100	4KTC112	4KTC132
264904	*					
265072		*	*	*	*	*

7.	LINE BUSHING	1
	ADERLEITUNGSDURCHFÜHRUNGEN	
	SKOZNIK	

	4KTC71	4KTC80	4KTC90	4KTC100	4KTC112	4KTC132
265164	*	*	*	*	*	
265162						*

9.	TERMINAL BOARD Exe	1
	KLEMMBRETT Exe	
	PRIKLJUČNI BLOK Exe	

	4KTC71	4KTC80	4KTC90	4KTC100	4KTC112	4KTC132
265889	*					
265884		*	*	*	*	*

ITEM No.	PART No.	DENOMINATION	QUANTITY
POS. Nr.	ARTIKEL Nr.	BEZEICHNUNG	ANZAHL
POZICIJA	RAZPOZNAVNA ŠT.	IME	KOLIČINA

10.	MINI TERMINAL Exe PTC	1
	MINIKLEMME Exe PTC	
	MINI PRIKLJUČNI BLOK Exe PTC	

	4KTC71	4KTC80	4KTC90	4KTC100	4KTC112	4KTC132
107773	2	3	3	3	3	3

11.	FOOT – LEFT	1
	FUSS - LINKS	
	NOGA – LEVA	

	4KTC71	4KTC80	4KTC90	4KTC100	4KTC112	4KTC132
264891	*					
265060		*				
265288			*			
265473				*		
265645					*	
265780						*

12.	FOOT – RIGHT	1
	FUSS – RECHT	
	NOGA – DESNA	

	4KTC71	4KTC80	4KTC90	4KTC100	4KTC112	4KTC132
264891	*					
265060		*				
265289			*			
265473				*		
265645					*	
265781						*

13.	FAN 2-poles	1
	LUFTER –2polig	
	VENTILATOR 2-polni	

	Material	4KTC71	4KTC80	4KTC90	4KTC100	4KTC112	4KTC132
271527	plastic	*					
265122	plastic		*				
265340	plastic			*			
265525	plastic				*		
265676	plastic					*	
265843	plastic						*

14.	FAN 4,6,8-poles	1
	LUFTER 4,6,8polig	
	VENTILATOR 4,6,8-polni	

	material	4KTC71	4KTC80	4KTC90	4KTC100	4KTC112	4KTC132
271527	plastic	*					
271528	plastic		*				
271529	plastic			*			
271523	plastic				*		
271524	plastic					*	
271525	plastic						*

ITEM No.	PART No.	DENOMINATION	QUANTITY
POS. Nr.	ARTIKEL Nr.	BEZEICHNUNG	ANZAHL
POZICIJA	RAZPOZNAVNA ŠT.	IME	KOLIČINA

15.	FAN COVER	1
	LUFTERHAUBE	
	VENTILATORSKI ŠČIT	

	4KTC71	4KTC80	4KTC90	4KTC100	4KTC112	4KTC132
264955	*					
265125		*				
265343			*			
265528				*		
265678					*	
265847						*

16.	FAN COVER WITH RAIN CAP IMV1/IMV5	1
	LUFTERHAUBE MIT REGENSCHUTZDACH IMV1/IMV5	
	VENTILATORSKI ŠČIT IMV1/IMV5	

	4KTC71	4KTC80	4KTC90	4KTC100	4KTC112	4KTC132
264956	*					
265126		*				
265344			*			
265529				*		
265679					*	
265848						*

17.	STATOR WINDING	1
	STATORPAKET MIT WICKLUNG	
	NAVIT STATORSKI PAKET	

		4KTC71	4KTC80	4KTC90	4KTC100	4KTC112	4KTC132
264979	A2	*					
264984	A4	*					
264989	A6	*					
	A8	*					
264982	B2	*					
264986	B4	*					
264990	B6	*					
264991	B8						
265180	A2		*				
265190	A4		*				
265207	A6		*				
265213	A8		*				
265185	B2		*				
265197	B4		*				
265210	B6		*				
265214	B8		*				
265372	L2			*			
265383	L4			*			
265392	L6			*			
265398	L8			*			
265368	S2			*			
265376	S4			*			
265389	S6			*			
265396	S8			*			
265566	L2				*		
265570	LA4				*		
265575	LB4				*		
265580	L6				*		
265584	LA8				*		
265585	LB8				*		
265696	M2					*	
265701	M4					*	

ITEM No.	PART No.	DENOMINATION				QUANTITY
POS. Nr.	ARTIKEL Nr.	BEZEICHNUNG				ANZAHL
POZICIJA	RAZPOZNAVNA ŠT.	IME				KOLIČINA

265705	M6					*	
265708	M8					*	
265895	SA2						*
265901	SB2						*
265906	S4						*
265914	S6						*
265922	S8						*
265910	M4						*
265918	MA6						*
265920	MB6						*
265925	M8						*

18.	PRE LOAD SPRING						1
	VORSPANNFEDERN						
	LEŽAJNA PODLOŽKA						

	4KTC71	4KTC80	4KTC90	4KTC100	4KTC112	4KTC132
267263	40					
268719		47				
272909			52			
268720				62	62	
268721						80

19.	BEARING **** 2Z C3						2
	LAGER **** 2Z C3						
	LEŽAJ **** 2Z C3						

	4KTC71	4KTC80	4KTC90	4KTC100	4KTC112	4KTC132
268779	6203					
268780		6204				
268784			6205			
268788				6206	6206	
268791						6208

20.	OIL SEAL DIN 3760 NBR						2
	DICHTRING DIN 3760 NBR						
	OLJNO TESNILO DIN 3760 NBR						

	4KTC71	4KTC80	4KTC90	4KTC100	4KTC112	4KTC132
268921	A17x40x7					
268914		A20x47x7				
268897			A25x52x7			
268901				A30x62x7	A30x62x7	
268906						A40x80x10

21.	SEAL FOR TERMINAL BOX Exe						1
	KLEMMENKASTEN DICHTUNG Exe						
	TESNILO						

	4KTC80	4KTC90	4KTC100	4KTC112	4KTC132
272707	*	*	*	*	*

22.	SEAL FOR TERMINAL BOX COVER Exe						1
	KLEMMENKASTENDECKEL DICHTUNG Exe						
	TESNILO						

	4KTC71	4KTC80	4KTC90	4KTC100	4KTC112	4KTC132
272707	*					
272707		*	*	*	*	*

ITEM No.	PART No.	DENOMINATION				QUANTITY
POS. Nr.	ARTIKEL Nr.	BEZEICHNUNG				ANZAHL
POZICIJA	RAZPOZNAVNA ŠT.	IME				KOLIČINA

		REDUCER Exe				
		UBERGUNGSSTUCKE Exe				
		PRILAGODITVENI ČLEN Exe				

23.		4KTC71	4KTC80	4KTC90	4KTC100	4KTC112	4KTC132
		max. 2					
			max. 2	max. 2	max. 2	max. 2	max. 2

24.		4KTC71	4KTC80	4KTC90	4KTC100	4KTC112	4KTC132
		max. 2					
			max. 2	max. 2	max. 2	max. 2	max. 2

25.		CABLE GLAND Exe				
		KABELVERSCHRAUBUNG Exe				
		DOVODNICA Exe				

	4KTC71	4KTC80	4KTC90	4KTC100	4KTC112	4KTC132
122394	max. 2					
122395		max. 2	max. 2	max. 2	max. 2	max. 2

26.		CABLE GLAND Exe				1
		KABELVERSCHRAUBUNG Exe				
		DOVODNICA Exe				

	4KTC71	4KTC80	4KTC90	4KTC100	4KTC112	4KTC132
122394	*	*	*	*	*	*

	PLUG Exe				
	VERSCHLUSSSTOPFEN Exe				
	SLEPI ČEP Exe				

27.		4KTC71	4KTC80	4KTC90	4KTC100	4KTC112	4KTC132
	272238	max. 2					
	272239		max. 2	max. 2	max. 2	max. 2	max. 2

28.		4KTC71	4KTC80	4KTC90	4KTC100	4KTC112	4KTC132
	272238	1	1	1	1	1	1

29.		EARTH PLATE				1
		ERDUNGSPLATTE				
		OZEMLJILNA PLOŠČICA				

	4KTC71	4KTC80	4KTC90	4KTC100	4KTC112	4KTC132
258970	*	*	*	*	*	*

30.		LACH WASHER				1
		SICHERUNGSSHEIBE				
		PRITRDILNA PLOŠČICA				

	4KTC71	4KTC80	4KTC90	4KTC100	4KTC112	4KTC132
257968	*	*	*	*	*	*

ITEM No.	PART No.	DENOMINATION	QUANTITY
POS. Nr.	ARTIKEL Nr.	BEZEICHNUNG	ANZAHL
POZICIJA	RAZPOZNAVNA ŠT.	IME	KOLIČINA

		EXTERNAL CIRCLIP DIN 471	
		SPRENGRING DIN 471	
		VSKOČNIK DIN 471	

31.			4KTC71	4KTC80	4KTC90	4KTC100	4KTC112	4KTC132
	268945	17	2					
	268947	20		2				
	268950	25			2			
	268952	30				2	2	
	268955	40						2

32.	268943	14	1					
	268946	18		1				
	268949	24			2			
	268952	30				2	1	
	268955	40						2

33.			INTERNAL CIRCLIP DIN 472	
			SPRENGRING DIN 472	
			VSKOČNIK DIN 472	

			4KTC71	4KTC80	4KTC90	4KTC100	4KTC112	4KTC132
	268933	40	1					
	268934	48		1				
	268935	52			1			
	268937	62				1	1	
	268939	80						1

			SLOTTED HEAD BOLD AND SCREW	
			SCHLITZSCHRAUBEN	
			VALJNI VIJAK	

34.			4KTC71	4KTC80	4KTC90	4KTC100	4KTC112	4KTC132
	271976	M5x18	2	2	2	2	2	2

35.			4KTC71	4KTC80	4KTC90	4KTC100	4KTC112	4KTC132
	271973	M5x12	1	1	1	1	1	1

36.			4KTC71	4KTC80	4KTC90	4KTC100	4KTC112	4KTC132
	271989	M6x12	1	1	1	1	1	1

			SCREW	
			SCHRAUBEN	
			VIJAK	

37.			4KTC71	4KTC80	4KTC90	4KTC100	4KTC112	4KTC132
	271794	M5x12	4	4	4	4	4	4

			HEXAGO SOCKET HEAD BOLD	
			INNERSECHKANTSCHRAUBEN	
			VIJAK S ŠESTROBO LUKNJO	

38.			4KTC71	4KTC80	4KTC90	4KTC100	4KTC112	4KTC132
	271887	M6x20	2	2	2	2	2	2

39.			4KTC80	4KTC90	4KTC100	4KTC112	4KTC132
	271887	M6x20	4	4	4	4	4

40.			4KTC71	4KTC80	4KTC90	4KTC100	4KTC112	4KTC132
	271887	M6x20	4	4	4	4	4	4
		M10x25						

ITEM No.	PART No.	DENOMINATION					QUANTITY
POS. Nr.	ARTIKEL Nr.	BEZEICHNUNG					ANZAHL
POZICIJA	RAZPOZNAVNA ŠT.	IME					KOLIČINA

41.			4KTC71	4KTC80	4KTC90	4KTC100	4KTC112	4KTC132
	271892	M6x35	4					
	271892	M6x35		4				
	271910	M8x40			4			
	271912	M8x50				4	4	
	271838	M10x60						4

42.			4KTC71	4KTC80	4KTC90	4KTC100	4KTC112	4KTC132
	271900	M8x20	4	4	4			
	271902	M8x25				4	4	
		M10x25						4

43.			4KTC71	4KTC80	4KTC90	4KTC100	4KTC112	4KTC132
	271887	M6x20	4	4	4	4		
	271900	M8x20					4	
	271833	M10x30						4

		SPRING VASHER						
		GLATTET FEDERING						
		VZMETNA PODLOŽKA						

45.			4KTC71	4KTC80	4KTC90	4KTC100	4KTC112	4KTC132
	271695	6	1	1	1	1	1	1

46.			4KTC71	4KTC80	4KTC90	4KTC100	4KTC112	4KTC132
	271694	5	2	2	2	2	2	2

47.			4KTC71	4KTC80	4KTC90	4KTC100	4KTC112	4KTC132
	271695	6	1	1	1	1	1	1

48.			4KTC71	4KTC80	4KTC90	4KTC100	4KTC112	4KTC132
	271695	6	2	2	2	2	2	2

49.			4KTC80	4KTC90	4KTC100	4KTC112	4KTC132
	271695	6	4	4	4	4	4

50.			4KTC71	4KTC80	4KTC90	4KTC100	4KTC112	4KTC132
	2711695	6	4	4	4	4	4	4

51.			4KTC71	4KTC80	4KTC90	4KTC100	4KTC112	4KTC132
	271723	8	4	4	4	4	4	
	271699	10						4

52.			4KTC71	4KTC80	4KTC90	4KTC100	4KTC112	4KTC132
	271692	4						
	271694	5	4	4	4	4	4	4

53.			4KTC71	4KTC80	4KTC90	4KTC100	4KTC112	4KTC132
	271695	6	4	4	4	4		
	271723	8					4	
	271699	10						4

54.			4KTC71	4KTC80	4KTC90	4KTC100	4KTC112	4KTC132
	271695	6	4					
	271723	8		4	4	4	4	
	271699	10						4

ITEM No.	PART No.	DENOMINATION	QUANTITY
POS. Nr.	ARTIKEL Nr.	BEZEICHNUNG	ANZAHL
POZICIJA	RAZPOZNAVNA ŠT.	IME	KOLIČINA

	KEY		
	PASSFEDER		
	MOZNIK		

56.			4KTC71	4KTC80	4KTC90	4KTC100	4KTC112	4KTC132
	272039	A5x5x20	1					
	271645	A6x6x32		1				
	271649	A8x7x40			1			
	271651	A8x7x50				1	1	
	271622	A10x8x70						1

57.			4KTC71	4KTC80	4KTC90	4KTC100	4KTC112	4KTC132
		A5x5x12	1					
		B6x6x10		1				
		B6x6x14			1	1	1	
		B8x7x18						1

58.	TERMINAL BOX Exd							1
	KLEMMENKASTEN Exd							
	PRIKLJUČNA OMARICA Exd							

	4KTC80	4KTC90	4KTC100	4KTC112	4KTC132
265041	*	*	*	*	*

59.	COVER FOR TERMINAL BOX Exd							1
	KLEMMENKASTENDECKEL Exd							
	POKROV PRIKLJUČNE OMARICE Exd							

	4KTC71	4KTC80	4KTC90	4KTC100	4KTC112	4KTC132
264905	*					
265073		*	*	*	*	*

	STOPPING PLUG Exd - PTC							
	VERSCHLUSSSTOPFEN Exd - PTC							
	SLEPI ČEP Exd - PTC							

60.	4KTC71	4KTC80	4KTC90	4KTC100	4KTC112	4KTC132
270610	*	*	*	*	*	*

	STOPPING PLUG Exd							
	VERSCHLUSSSTOPFEN Exd							
	SLEPI ČEP Exd							

61.	4KTC71	4KTC80	4KTC90	4KTC100	4KTC112	4KTC132
270610	*					
		*	*	*	*	*

	MOUNTING RAIL							
	KLEMMBRETT TRAGER							
	NOSILEC SPONKE							

62.	4KTC71	4KTC80	4KTC90	4KTC100	4KTC112	4KTC132
270610	*					
		*	*	*	*	*

63.	STATOR HOUSING DIRECT ENTRY							1
	GEHAUSE							
	OHIŠJE STATORJA DIREKTNI UVOD							

	4KTC71
264917	*

ITEM No.	PART No.	DENOMINATION	QUANTITY
POS. Nr.	ARTIKEL Nr.	BEZEICHNUNG	ANZAHL
POZICIJA	RAZPOZNAVNA ŠT.	IME	KOLIČINA

64.	LINE BUSHING CASING	1
	LEITUNGSDURCHFÜHRUNG GEHÄUSE	
	OHIŠJE SKOZNIKA DU	

	4KTC71-132
265085	*

65.	LINE BUSHING DIRECT ENTRY	1
	ADERLEITUNGSDURCHFÜHRUNGEN	
	SKOZNIK DIREKTNI UVOD	

	4KTC71-132
290177	*

When ordering spare parts, please state:
Item No., motor type, serial No.

EXAMPLE:

1. _____ Rotor 4KTC 80 A2 000000
--

Bei Ersatzteil Bestellung sind folgende
Angaben erforderlich:
Ersatzteillbezeichnung Typ, Motornummer
Serial Nr.

BEISPIEL:

1. _____ Rotor 4KTC 80 A2 000000
--

Pri naročilu nadomestnega dela, prosimo navedite:
Pozicija, tip motorja, serijska številka.

PRIMER:

1. _____ Rotor 4KTC 80 A2 000000
--

ATTENTION: THE SPARE PARTS WRITTEN IN BOLD LETTERS ARE SUBJECT TO DIMENSIONAL ACCURACY INSPECTION (SEE 60079-0, EN 60079-1 / IEC 60079-0, IEC 60079-1).

ACHTUNG: DIE MASSE DER FETT GEDRUCKT GEKENNZEICHNETTEN ERSATZTEILE MÜSSEN BESONDEREN GENAUIGKEITSKONTROLLEN UNTERZOGEN WERDEN (SIEHE EN 60079-0, EN 60079-1 / IEC 60079-0, IEC 60079-1).

OPOMBA: SESTAVNI DELI, NAPISANI Z Poudarjenimi črkami so posebej kontrolirani (GLEJ EN 60079-0, EN 60079-1 / IEC 60079-0, IEC 60079-1).

Navodila za montažo in priključitev ne zajemajo vseh posebnosti, ki se lahko pojavijo pri priključitvi in uporabi elektromotorja. Zahteva se, da elektromotor priključi in vzdržuje kvalificirana oseba (IEC 364).

1. TRANSPORT IN SKLADIŠČENJE

ELEKTROMOTORJE MORAMO TRANSPORTIRATI V POLOŽAJU, KOT SO PREDVIDENI ZA OBRATOVANJE! ELEKTROMOTORJE, KI JIH NE UPORABIMO TAKOJ, MORAMO SKLADIŠČITI V SUHEM PROSTORU.

2. OZNAKA PROTIEKSPLOZIJSKE ZAŠČITE

Oznaka protiekspluzijske zaščite s katero je lahko označen motor:



II 2G Ex db IIC T4 – T6 Gb



II 2G Ex db IIB T4 – T6 Gb

ali



II 2G Ex db eb IIC T4 – T6 Gb



II 2G Ex db eb IIB T4 – T6 Gb

ali



II 2D Ex tb IIIC T135°C – 85°C Db

Ex db IIC T* Gb

Ex db IIB T* Gb

or

Ex db eb IIC T* Gb

Ex db eb IIB T* Gb

or

Ex tb IIIC T*°C Db



: Znak za protiekspluzijsko zaščito

II:	skupina opreme II, kamor spadajo naprave za vse potencialne eksplozivne atmosfere, razen rudnikov
2:	kategorija opreme 2, ki zajema opremo, ki se lahko uporablja v conah 1 in 2
G:	oprema za eksplozivne atmosfere, kjer so prisotni plini, hlapi ali eksplozivna zmes
D:	oprema za eksplozivne atmosfere, kjer je prisoten prah
Ex:	oznaka za protiekspluzijsko zaščito
db:	vrsta protiekspluzijske zaščite, neprodorni okrov
eb:	vrsta protiekspluzijske zaščite, povečana varnost
tb:	zaščita pred vžigom prahu in odpornost proti vdoru prahu
IIB:	skupina plinov B
IIC:	skupina plinov C
T4, T6:	temperaturni razred
T135°C – T85°C:	maksimalna temperatura na površini opreme
Gb, Db :	eksplozijski nivo opreme

2.1 TEMPERATURNO OBMOČJE DELOVANJA MOTORJA

ATEX:

Tabela 1: Temperaturno območje delovanja motorja (ATEX).

<u>Type of protection</u>	<u>Explosion group</u>	<u>Lower limit</u>	<u>Upper limit</u>
<u>Ex db</u>			
<u>Standard stator housing</u>	<i>IIC</i>	-50 °C	60 °C
	<i>IIB</i>	-50 °C	85 °C
<u>Extended stator housing FS71 – FS132</u>	<i>IIC</i>	-20 °C	60 °C
	<i>IIB</i>	-20 °C	85 °C
<u>Extended stator housing FS160 – FS225</u>	<i>IIC</i>	-50 °C	60 °C
	<i>IIB</i>	-50 °C	85 °C
<u>Ex db eb</u>	<i>IIB / IIC</i>	-20 °C	60 °C
<u>Ex tb</u>	<i>IIIC</i>	-30 °C	85 °C

IECEX:

Tabela 2: Temperaturno območje delovanja motorja (IECEX).

<u>Type of protection</u>	<u>Explosion group</u>	<u>Lower limit</u>	<u>Upper limit</u>
<u>Ex db</u>			
<u>Standard stator housing</u>	<i>IIC</i>	-20 °C	60 °C
	<i>IIB</i>	-20 °C	60 °C
<u>Extended stator housing FS71 – FS132</u>	<i>IIC</i>	-20 °C	60 °C
	<i>IIB</i>	-20 °C	60 °C
<u>Extended stator housing FS160 – FS225</u>	<i>IIC</i>	-50 °C	60 °C
	<i>IIB</i>	-50 °C	60 °C
<u>Ex db eb</u>	<i>IIB / IIC</i>	-20 °C	60 °C
<u>Ex tb</u>	<i>IIIC</i>	-30 °C	85 °C

Temperaturno območje delovanja za standardne motorje: -20/+40°C.

POSEBNE IZVEDBE

- Temperatura okolice do max. -50°C, le v Exd izvedbi
- Temperatura okolice nad 40°C (do max. 85°C – le za skupino plinov IIB)

2.2 ŠTEVILKA CERTIFIKATA

BVS 13 ATEX E 125 X

IECEX BVS 13.0121 X

X – mere Ex rež niso v skladu s podatki v tabelah 1 in 2 v standardu EN 60079-1 (IEC 60079-1).

3. UPORABA

Trifazni asinhronski elektromotorji v protieksplzijski izvedbi tipa 4KT(B)CD so namenjeni za obratovanje v industrijskih objektih, v katerih je obstaja nevarnost eksplozije gorljivih plinov, par vnetljivih tekočin ali gorljivega prahu.

Protieksplzijsko zaščitno elektromotorjev sestavljajo:

- »nepredirni okrov« za ohišje elektromotorja in »povečana varnost« za priključno omarico, ki sta v skladu z zahtevami standardov EN 60079-0 (IEC 60079-0), EN 60079-1 (IEC 60079-1) in EN 60079-7 (IEC 60079-7). Na pokrovu priključne oznake je oznaka Ex.
- »nepredirni okrov« za ohišje elektromotorja in za priključno omarico, ki sta v skladu z zahtevami standardov EN 60079-0 (IEC 60079-0) in EN 60079-1 (IEC 60079-1). Na pokrovu priključne oznake je oznaka Ex.

- »protiprašna zaščita« za ohišje elektromotorja in za priključno omarico, v skladu z zahtevami standarda EN 60079-31 (IEC 60079-31).

Ohišja elektromotorjev so izdelana po zahtevah za skupino plinov IIC.

Standardna izvedba elektromotorjev je za temperaturni razred T4, oziroma T135°C.

Točna oznaka protieksplzijske zaščite je na napisni tablici.

4. NAMESTITEV (MONTAŽA) ELEKTROMOTORJA

MONTAŽO ELEKTROMOTORJA NAJ IZVEDE STROKOVNJAK, DA SE IZOGNEMO MOREBITNIM OKVARAM MED OBRATOVANJEM ZARADI NEPRAVILNE MONTAŽE.

Pri namestitvi elektromotorja moramo:

- upoštevati zahteve instalacijskih predpisov
- preveriti, če protieksplzijska zaščita elektromotorja ustreza okolju (cona, skupina plinov, temperaturni razred)
- preveriti kako okolje vpliva na delovanje elektromotorja (agresivno okolje, temperatura, prah itd.)
- upoštevati lokalne in tovarniške posebnosti ter zahteve
- zagotoviti uporabo pravega orodja in priprav
- upoštevati zahteve za varno obratovanje
- zagotoviti uporabo osebnih zaščitnih sredstev

Pri montaži (postavitvi) elektromotorja na prostem priporočamo, da ga zaščitimo pred neposrednimi sončnimi žarki. Na elektromotorju, ki obratuje v navpičnem položaju, moramo nad odprtini štita ventilatorja namestiti pokrov, za zaščito elektromotorja pred vdorom vode vzdolž osi.

Izolacija elektromotorjev je iz materialov, ki ne vpijajo vlage in je kvalitetno impregnirana, zato pravilno skladiščeni, novih elektromotorjev pred priključevanjem na omrežje, ni potrebno posebej preizkušati.

Pred zagonom ali če sumite, da je v navitje vdrla vlaga, izmerite upornost izolacije. Upornost, merjena pri 25°C mora presežati referenčno vrednost, ki znaša 100MΩ (pri enosmerni naopetosti 500 ali 1000V). Upornost izolacije se razpolovi na vsakih 20°C dviga temperature okolice.

Če referenčne vrednosti upornosti ni mogoče doseči, je navitje preveč vlažno in ga je treba posušiti v peči. Temperatura peči naj prvih 12 do 16 ur znaša 90°C, nato pa od 6 do 8 ur 105°C.

Pri montaži elementov, npr. sklopke, jermenice) na gred elektromotorja, je potrebno posebej paziti na ležaje. Aksialnih sil zaradi morebitnih udarcev ob montaži, ne smejo prevzeti ležaji.

5. PRIKLJUČEK NA OMREŽJE

POMEMBNO!

NAPRAVE V PROTIEKSPLOZIJSKI IZVEDBI SME MONTIRATI IN PRIKLJUČITI NA OMREŽJE LE STROKOVNO USPOSOBLJENA OSEBA, KI IMA DODATNO ZNANJE S PODROČJA PRITIEKSPLOZIJSKE ZAŠČITE.

Pred priključitvijo elektromotorja na omrežje je potrebno preveriti:

- ali podatki na napisni tablici ustrezajo napetosti in frekvenci omrežja
- ali protieksplzijska zaščita motorja ustreza za okolje v katerem bo motor obratoval (skupina plinov in temperaturni razred).
- ali je instalacija (cevna ali kabelska) korektno izvedena

Elektromotorji se vrtijo desno, če fazne vodnike L1, L2, L3, priključimo na priključke U, V, W, (1U, 1V, 1W, oziroma U1, V1, W1). Spremembo smeri vrtenja dosežemo z zamenjavo priključnih mest dveh dovodnih faznih vodnikov.

Naslednji element se nahajajo na številkah:

10 – 11 ali 12 – 13:	PTC termistor
14 – 15:	NC termostat – odpirajoč (normalno zaprt kontakt)
16 – 17:	NO termostat – zapirajoč (normalno odprt kontakt)

Navitja elektromotorjev imajo vgrajene temperaturne senzorje (PTC termistor DIN 44081). Odklopna naprava s katero so povezani, mora biti odobrena in nositi ustrezno oznako pooblaščenega Ex institucije. Odklopna naprava ni eksplozijsko varna in mora biti instalirana zunaj eksplozijsko varnega območja (ali vgrajena v atestiranem eksplozijsko varnem ohišju). Oznaka ustreznosti služi le za potrditev skladnosti električnih veličin v povezavi s temperaturnimi senzorji in dovoljuje uporabo odobrene odklopne

naprave v povezavi s PTC senzorji, ki ustrezajo zahtevam DIN 44081 za termično zaščito eksplozijsko varnih elektro naprav.

Grelci so priključeni na sponke 30 – 31 ali 32 – 33.

Motorji z vgrajenimi grelci so označeni z dodatno tablico z imenskimi podatki grelnega sistema ali pa so ti podatki vključeni na tablici s podatki motorja.

Krmiljenje mora zagotoviti, da napetost ni istočasno priključena na grelce in priključne sponke elektromotorja.

Priključek kabljskih žil na skoznike mora biti izveden posebej pazljivo. Izolacije kabljske žile naj bo čim bližje priključnemu mestu, vse žice finožičnatih žil pa morajo biti vpete na priključnem mestu.

Pri izvedbi protieksplzijske zaščite omarice Ex d (nepredirni okrov), je potrebno obvezno upoštevati instalacijske predpise in zagotoviti korektno protieksplzijsko zaščito na uvodu kabla (Ex d uvodnica).

Pred priključitvijo na omrežje v priključni omarici kontroliramo:

- da v notranjosti priključne omarice ni prahu, žičnih ostankov in podobno
- da izvede priključitev strokovno usposobljena oseba, ki zagotavlja, da bodo električni spoji kvalitetni in vijaki primerno pritrjeni
- da je medsebojna zračna razdalja pri napetosti 630V ali 400 V znaša minimalno 10 mm
- da so neuporabne žice ločene in primerno pritrjene
- da so stične ploskve očiščene in rahlo namazane z brez kislinasto mastjo tip FOR PD-2 (Setral MI PD LL/2A) ali Renolit RHF-1 Fuchs
- da je kabel na uvodnici pravilno zatesnjen
- neuporabljene odprtine morajo biti zaprte in zatesnjene v skladu z zahtevami protieksplzijske zaščite
- slepi čepi, ki so deli nepredirnega okrova, morajo biti konstruirani tako, da jih je mogoče odstraniti le s pomočjo ustreznega orodja (v skladu z zahtevami standarda EN 60079-0, točka 16.4)

6. ZAŠČITA ELEKTROMOTORJEV IN OBRATOVANJE

Pri postavitvi elektromotorja je vse vrteče dele potrebno zavarovati pred dotikom.

S stroji smejo opravljati samo kvalificirane osebe.

Pri trajnem obratovanju (oznaka S1), je motorsko zaščitno stikalo zadostna zaščita z ozirom na temperaturni razred, če ima vgrajeno ustrezno bimetalno zaščito, ki omogoča nastavitve imenskega toka.

Pri obratovanju S2 (kratkotrajno obratovanje s trajno obremenitvijo) ali S3 (prekinjeno obratovanje) ter pri (frekvenčno reguliranem pogonu), obratovanje s frekvenčnim pretvornikom, morajo imeti trifazni kratkostični elektromotorji v vsakem navitju temperaturne senzorje, po enega v vsaki fazi (DIN 44 080, DIN 44 081, DIN 44 082).

Izklopna temperatura senzorjev je običajno 145°C. Odgovarjajoča odklopna naprava z oznako ustreznosti tvori skupaj s temperaturnimi senzorji ustrezen sistem zaščite z ozirom na zahtevani temperaturni razred.

Elektromotorji z dvema hitrostma vrtenja (dvoje ločenih navitij ali eno navitje v Dahlander stiku), morajo biti zaščiteni za vsako hitrost posebej.

Ohišje elektromotorja mora biti povezano z zaščitnim vodnikom in ozemljeno. V priključni omarici je vijak za priključitev zaščitnega vodnika, na ohišju statorja pa je vijak za ozemljitev.

Če je elektromotor napajan preko frekvenčnega pretvornika, je potrebno preveriti, da nastavitve na pretvorniku ustreza deklariranemu območju na dodatni napisni tablici. Elektromotor mora biti varovan dvojno, to je z motorskim zaščitnim stikalom, ter s temperaturno zaščito. Izklopna naprava, vezana na temperaturno zaščito, mora biti v območju: $2k\Omega < R_o < 4k\Omega$, pri čemer je R_o – upornost izklopa. Motorsko zaščitno stikalo mora biti certificirano.

7. VZDRŽEVANJE

Elektromotorji so robustne konstrukcije in nezahtevni za vzdrževanje.

V rednih časovnih obdobjih (odvisno od okolja), je potrebno elektromotor očistiti, še posebej vhodne odprtine na ventilatorskem ščitu: tako zagotovimo zadosten pretok zraka za hlajenje.

Elektromotorji so opremljeni z zaprtimi trajno mazanimi ležaji. Življenjska doba ležajev je 20000 ur obratovanja dvopolnih elektromotorjev ($n_s=3000 \text{ min}^{-1}$) pri normalnih pogojih obratovanja ali 40000 ur obratovanja štiri in več polnih motorjev.

Redni kontrolni pregledi in kontrolne meritve, ki jih opravijo za ta dela usposobljene osebe, so ukrepi, s katerimi zmanjšamo možnost okvar in prekinitev obratovanja.

Vsako odstopanje od imenskih vrednosti (večji tok obratovanja, povečana temperatura, vibracije, neobičajni hrup ali vonj, reagiranje zaščitno – kontrolnih naprav itd.) so znak, da s pogonom nekaj ni v redu! Da bi se

izognili večji okvari, ki bi lahko neposredno ali posredno povzročila večjo škodo na materialnih dobrinah ali poškodbe ljudi, je potrebno o teh pojavih takoj obvestiti odgovorno osebo.

8. POPRAVILO

ELEKTROMOTORJE V PROTIEKSPLOZIJSKI IZVEDBI SME POPRAVLJATI SAMO PROIZVAJALEC ALI POOBlašČENA DELAVNICA. OSEBE, KI RAZSTAVLJAJO ALI POPRAVLJAJO Ex APARATE, MORAJO BITI STROKOVNO USPOSOBLJENE IN IMETI DODATNO ZNANJE S PODROČJA PROTIEKSPLOZIJSKE ZAŠČITE.

POMEMBNO:

Popravilo Ex rež po podatkih v tabelah 1 in 2 standarda EN 60079-1 ni dovoljeno!
Prosimo, da se v primeru popravila Ex rež posvetujete s proizvajalcem!

Pri razstavljanju elektromotorja je potrebno paziti, da ne poškodujemo površin, ki tvorijo Ex rež!

Pred sestavljanjem elektromotorja je potrebno vse Ex površine očistiti in premazati z brezislinsko mastjo, tip FOR PD-2 (Setral MI PD LL/2A) ali Renolit RHF-1 Fuchs.

Po popravilu elektromotorja morajo tehnične zahteve elektromotorja ostati v skladu s certifikatom.

Če se pri popravilu ugotovi, da »nepredirni okrov« ne ustreza več zahtevam protiekspluzijske zaščite in zahtevam v certifikatu, se morajo z elektromotorja odstraniti oznake protiekspluzijske zaščite.

9. MOMENT PRIVITJA VIJAKOV

Tabela 3: Moment privitja vijakov Ex ohišja. Material vijakov 8.8 ali A4-70.

Navoj	Moment privitja vijakov (Nm)	Navoj	Moment privitja vijakov (Nm)
M4	2.3	M12	66
M5	4.6	M14	105
M6	7.9	M16	160
M8	19	M20	330
M10	38	M24	560

Tabela 4: Moment privitja vijakov - električni priključki.

Navoj	Moment privitja vijakov (Nm)	Navoj	Moment privitja vijakov (Nm)
M4	1.2	M10	10
M5	2	M12	15.5
M6	3	M16	30
M8	6	M20	52

10. PRIPOROČENE VREDNOSTI MOMENTA ZA PRITRJEVANJE STANDARDNIH Exe UVODNIC (Nm)

Tabela 5: Priporočene vrednosti momenta za pritrjevanje Exe uvodnic WISKA, tip ESKE-...

Velikost uvodnice	Pritrdilni vijak (Nm)	Pritrdilna matica (Nm)	Premer kabla (mm)
ESKE-.12	2,0	2,0	3 - 6
ESKE-.16	1,8	1,3	4 - 9
ESKE-.20	2,3	1,5	6 - 13
ESKE-.25	3,0	2,0	7 - 12 / 10 - 17
ESKE-.32	4,5	3,0	13 - 21
ESKE-.40	11,0	10,0	17 - 28
ESKE-.50	13,0	12,0	23 - 35
ESKE-.63	17,0	16,0	31 - 48

11. Tabela izkoristkov v skladu z IE3

Tabela 6: Izkoristki v skladu z IE3.

Nazivna moč [kW]	Število polov											
	2			4			6			8		
	100%	75%	50%	100%	75%	50%	100%	75%	50%	100%	75%	50%
0,25	-	-	-	73,6	71,2	65,4	68,6	64,5	58,4	64,1	59,4	51,6
0,37	75,2	72,9	66,6	77,3	74,5	70,2	73,5	70,0	64,3	69,3	65,6	59,2
0,55	78,7	78,8	77,2	80,8	79,4	75,1	77,2	74,7	69,9	73,0	70,4	65,5
0,75	81,1	81,4	79,3	82,6	82,6	80,0	78,9	77,3	74,9	75,0	72,8	69,4
1,1	83,3	84,3	83,3	84,1	81,5	78,1	81,0	79,5	77,2	77,7	75,7	72,6
1,5	85,1	86,1	85,6	85,3	84,9	82,2	82,5	81,1	78,9	79,7	77,9	75,0
2,2	85,9	86,8	86,4	86,7	85,7	84,0	84,3	83,0	81,0	81,9	80,3	77,7
3	87,1	87,1	85,7	87,7	87,2	85,6	85,6	84,4	82,5	83,5	82,0	79,7
4	88,1	86,3	83,7	89,2	88,7	86,2	86,8	85,6	83,9	84,8	83,5	81,4
5,5	89,8	87,5	84,3	90,3	91,1	90,1	88,0	86,9	85,3	86,2	84,9	83,0
7,5	90,1	89,8	88,5	90,6	90,6	89,1	89,1	88,1	86,5	87,3	86,3	84,5

These instructions for the installation and maintenance do not contain all particulars which might arise during the installation and application of the cage motor. We therefore insist on its being mounted and maintained by qualified persons (IEC 364).

1. TRANSPORT AND STORAGE

THE MOTORS ARE TO BE STORED IN A CLOSED AND DRY AREA. Should they be stored outdoors, it is important to protect them against bad weather conditions. During transport make sure that the usual precautions for this kind of material are respected. 4KT(B)CD motors are to be handled with lifting-claw.

2. EXPLOSION PROTECTION CODES

Possible markings



II 2G Ex db IIC T4 – T6 Gb



II 2G Ex db IIB T4 – T6 Gb

or



II 2G Ex db eb IIC T4 – T6 Gb



II 2G Ex db eb IIB T4 – T6 Gb

or



II 2 D Ex tb IIIC T135°C – 85°C Db

Ex db IIC T* Gb

Ex db IIB T* Gb

or

Ex db eb IIC T* Gb

Ex db eb IIB T* Gb

or

Ex tb IIIC T*°C Db



: Ex marking

II:	Device group II; equipment can be used in potentially explosive areas except for mining
2:	Category; for use in Zone 1 or Zone 2
G:	equipment for use in explosive atmosphere, caused by flammable gas
D:	equipment for use in explosive atmosphere, caused by combustible dust
db:	explosion protection type - flameproof enclosure
eb:	explosion protection type – increased safety
tb:	dust ignition protection, practice A for use in zone 21
IIB:	gas group IIB
IIC:	gas group IIC
T4, T6:	temperature class
T135°C – T85°C:	maximum surface temperature of motors

2.1 PERMITTED AMBIENT TEMPERATURE RANGE

ATEX:

Table 1: Permitted ambient temperature range (ATEX).

Type of protection	Explosion group	Lower limit	Upper limit
<i>Ex db</i>			
<i>Standard stator housing</i>	<i>IIC</i>	-50 °C	60 °C
	<i>IIB</i>	-50 °C	85 °C
<i>Extended stator housing FS71 – FS132</i>	<i>IIC</i>	-20 °C	60 °C
	<i>IIB</i>	-20 °C	85 °C
<i>Extended stator housing FS160 – FS225</i>	<i>IIC</i>	-50 °C	60 °C
	<i>IIB</i>	-50 °C	85 °C
<i>Ex db eb</i>	<i>IIB / IIC</i>	-20 °C	60 °C
<i>Ex tb</i>	<i>IIIC</i>	-30 °C	85 °C

IECEx:

Tabela 2: Permitted ambient temperature range (IECEx).

Type of protection	Explosion group	Lower limit	Upper limit
<i>Ex db</i>			
<i>Standard stator housing</i>	<i>IIC</i>	-20 °C	60 °C
	<i>IIB</i>	-20 °C	60 °C
<i>Extended stator housing FS71 – FS132</i>	<i>IIC</i>	-20 °C	60 °C
	<i>IIB</i>	-20 °C	60 °C
<i>Extended stator housing FS160 – FS225</i>	<i>IIC</i>	-50 °C	60 °C
	<i>IIB</i>	-50 °C	60 °C
<i>Ex db eb</i>	<i>IIB / IIC</i>	-20 °C	60 °C
<i>Ex tb</i>	<i>IIIC</i>	-30 °C	85 °C

Standard temperature range of motors is **-20/+40°C**.

SPECIAL DESIGN

- ambient temperature max. -50°C, only with Ex d protection
- ambient temperature above 40°C (max. 85°C – for gas group IIB only)

2.2 CERTIFICATE NUMBER

BVS 13 ATEX E 125 X

IECEx BVS 13.0121 X

X – stands for nonconformity of flameproof gaps and joints according to tabels 1 and 2 of EN60079-1 (IEC 60079-1).

3. APPLICATION AND EXPLOSION PROTECTION

The explosion-proof asynchronous three-phase squirrel-cage motors of the type 4KT(B)CD are designed for their application in industrial buildings with highly explosive atmospheres caused by flammable gases, steam, liquids or dust.

Explosion-proof motor versions are:

"Explosion-proof enclosure" for the motor housing and "Increased safety" for the terminal box according to EN 60079-0 (IEC 60079-0), EN 60079-1 (IEC 60079-1) and 60079-7 (IEC 60079-1). The cover of the terminal box carries the Ex imprint.

"Explosion-proof enclosure" for the motor housing and the terminal box according EN 60079-0 (IEC 60079-0) and EN 60079-1 (IEC 60079-1). The cover of the terminal box carries Ex imprint.

"Explosion by enclosure »tb« for the motor housing and the terminal box according to EN 60079-31 (IEC 60079-31) for use in the presence of combustible dust.

The standard electric motor is suitable for the T4 temperature class or maximum 135°C surface temperature of equipment.

The exact indication of the explosion protection can be found on nameplate of the motor.

4. INSTALLATION (MOUNTING) OF THE ELECTRIC MOTOR

THE ELECTRIC MOTOR MUST BE MOUNTED BY QUALIFIED PERSONS IN ORDER TO AVOID POSSIBLE DAMAGES DURING OPERATION CAUSED BY AN INCORRECT INSTALLATION.

The following rules must be observed during installation:

- strictly adhere to the installation instructions,
- check whether the explosion protection corresponds to the environment or not (sector, gas group, temperature group),
- check the effects of the environment on the operation of the electric motor (aggressive environment, temperature, dust ...),
- consider particulars and requirements of room/plant,
- make sure that the correct tools and devices are used,
- observe the motor safety instructions,
- make sure that the means for personal safety are used.

If mounted (installed) outdoors, the motors must be protected from direct sunlight. If the motor is mounted and operated in vertical position, the fan openings must be protected against the ingress of water or any other foreign objects by fixing the cover above them.

Measure insulation resistance before commissioning and when winding dampness is suspected. Insulation resistance, corrected to 25°C, must exceed the reference value, i.e. 100MΩ (measured with 500 or 1000 V DC). The insulation resistance value is halved for each 20°C rise in ambient temperature.

If the reference resistance value is not attained, the winding is too damp and must be oven dried. The oven temperature should be 90°C for 12-16 hours followed by 105°C for 6-8 hours.

When mounting the elements (such as clutch, pulley) on to the motor shaft, please pay particular attention to the bearings. The axial forces caused by possible impacts during installation must not have any effect on the bearings.

5. CONNECTION TO THE POWER SUPPLY

IMPORTANT!

THE EXPLOSION-PROOF VERSIONS MAY BE MOUNTED AND CONNECTED TO THE POWER SUPPLY BY QUALIFIED PERSONS ONLY; THE INSTALLER MUST HAVE ADDITIONAL KNOWLEDGE ABOUT EXPLOSION PROTECTION.

The following items must be checked before the electric motor can be connected to the mains power supply:

- that the data on the label correspond to voltage and frequency of the power supply,
- that the explosion protection indicated corresponds to the environment the electric motor will be operated in (gas group, temperature class),
- that the installation (pipes or cables) is carried out correctly.

The electric motors rotate clockwise when the phase conductors L1, L2 and L3 are connected to the terminals U,V,W (1U,1V,1W or U1,V1,W1). Rotation may be changed by switching the terminals on two phases of conductors.

The following elements are connected to the terminals:

- | | |
|------------------|--|
| 10 – 11 or 12-13 | PTC 145°C built in |
| 14 – 15 | Thermostats NC (normally closed contact) |
| 16 – 17 | Thermostats NO (normally open contact) |

The motors are equipped with 3 temperature detectors (PTC thermistor DIN 44081 -). These temperature detectors are to be connected to a tripping unit with one of Ex Notified Bodies mark of conformity. The tripping unit is not protected against explosions and must therefore be installed outside of the hazardous area. The mark of conformity serves merely to confirm the adherence to the electrical data at the interface

between the temperature detector circuit and the tripping device and to allow the application of both the tripping device with mark of conformity and the PTC contacts according to DIN 44081 for the thermal control of explosion-proof electric machines.

The space heaters are mounted to the terminals 30 – 31 (230V) or 32-33 (110V). Motors with space heaters are marked with an additional label indicating the nominal data of the heating system.

The electric control unit must make sure that the nominal motor voltage and the heater voltage are not present simultaneously.

Take particular care over the connection of the cable cores to the terminal board. The insulation of the cable cores should be close to the terminal, all wires of the flexible cores must be clamped to the terminal.

The tightening torque of the connections on the terminal board must not exceed 7,5 Nm.

Pay close attention to the installation instructions when carrying out the explosion protection of the Ex d terminal box («explosion-proof enclosure») and check for the correct explosion protection cable entry (Ex d entry).

Prior to the mains connection, check the terminal box for the following items:

- there must not be any dust, pieces of wire or other foreign matters inside of the terminal box,
 - the electrical connections must be carried out by qualified persons and the screws must be tightened correspondingly,
 - that the mutual air distance is at least 10 mm for voltages of 400 V or 630 V
 - that the unused wires are separated and fixed accordingly,
 - all joint areas are formly greased with grease type FOR PD-2 (Setral MI PD LL/2A) ali Renolit RHF-1 Fuchs
 - that the cable is sealed correctly at the cable entry.
 - the unused openings must be sealed so as to guarantee that the flame-proof properties are maintained.
- The means foreseen to achieve this goal must be such so as to ensure that the sealing-plug can only be removed with the help of a special tool (according to EN 60079-0 (IEC 60079-0), point, 16.4).

6. PROTECTION OF THE ELECTRIC MOTORS AND OPERATION

Succeeding the installation of the electric motors, all rotating parts must be safely protected against contacts. Only qualified personnel may handle the machines!

In the S1-mode of operation, the motor circuit-breaker is a sufficient device for the maintenance of the temperature class. To do so, it must be regulated to the rated current of the three-phase cage motor.

In both the S2- and S3- modes of operation and the converter operation, the three-phase cage motors must be equipped with 3 PTCs in each winding (DIN 44080, DIN 44081, DIN 44082). The nominal shutdown temperature of these PTCs are 145 °C. A corresponding shutdown device with the PTB mark of conformity (Lab. 3.43) completes the protective system for the maintenance of the temperature class.

Electric motors with two velocities (two separate windings or one winding in Dahlander coupling) must have a separate protection for each speed.

The housing of the electric motor must be connected to the protective conductor, and earthed. The terminal box contains the screw for the connection of the conductor, the earthing screw sits on the stator housing.

If the electric motor is supplied via the frequency converter, please make sure that the settings on the converter correspond to the data indicated on the supplementary label. The electric motor must be double-protected, i.e. with the motor circuit-breaker and the temperature protection. The shutdown device connected to the temperature protection must be in the range of $2k\Omega < R_o < 4k\Omega$ with R_o representing the shutdown resistance. The shutdown device must be certified.

7. MAINTENANCE

Electric motors have a robust structure and need no particular maintenance.

The motor must be cleaned in regular intervals (depending on the environment), especially the entry openings on the fan as to guarantee a sufficient air flow for the cooling system.

Electric motors feature closed and prelubricated bearings. The life span of the bearings is 20000 service hours for 2 pol electric motors ($n_s=3000 \text{ min}^{-1}$) under normal operating conditions or 40000 service hours for 4,6,8 and multiple-pol motors.

Regular inspections and control measurements carried out by qualified personnel are preferred to reduce possible damages and standstills.

Each deviation from the nominal values (such as higher load current, increased temperatures, vibrations, unusual noise or smell, reactions of protective devices) is to be understood as signal of possible damage! To prevent consequential damages on machines or people, please inform the person responsible immediately on the appearance of such deviations.

8. REPAIRS

ELECTRIC MOTORS FOR EXPLOSIVE AREAS MAY BE REPAIRED EXCLUSIVELY BY THE MANUFACTURER OR OUR AUTHORIZED REPRESENTATIVE.

THOSE WHO DISASSEMBLE AND REPAIR THE EX MACHINES MUST BE HIGHLY QUALIFIED AND DISPOSE OF ADDITIONAL KNOWLEDGE CONCERNING EXPLOSION PROTECTION.

IMPORTANT:

Repair according of flameproof gaps and joints according to table 2 of EN 60079-1 (IEC 60079-1) is not allowed! Please contact producer!

Special attention should be paid that no damage has occurred during disassembly on flameproof gaps and joints.

Before assembly of electromotor all flameproof gaps and joints need to be cleaned and greased with grease type FOR PD-2 (Setral MI PD LL/2A) or Renolit RHF-1 Fuchs.

If it becomes clear during repairs that the »explosion-proof enclosure« no longer corresponds to the requirements on the explosion protection and specified in the certification, all markings for explosion protection must be removed from this motor.

9. SCREW TIGHTENING TORQUE

Table 3: Tightening torque: Ex enclosure. Tightening torques for screws of the strength class 8.8 and A4-70.

Thread	Tightening torque (Nm)	Thread	Tightening torque (Nm)
M4	2.3	M12	66
M5	4.6	M14	105
M6	7.9	M16	160
M8	19	M20	330
M10	38	M24	560

Table 4: Tightening torque: for electrical connections.

Thread	Tightening torque (Nm)	Thread	Tightening torque (Nm)
M4	1.2	M10	10
M5	2	M12	15.5
M6	3	M16	30
M8	6	M20	52

10. RECOMENDED TORQUES FOR BARTEC-VARNOST STANDARD Exe CABLE GLANDS (Nm)

Table 5: Recommended tightening torque and terminal sizes for cable glands WISKA, typ ESKE-...

Cable gland size	Connection thread (Nm)	Pressing screw (Nm)	Terminal size (mm)
ESKE-.12	2,0	2,0	3 - 6
ESKE-.16	1,8	1,3	4 - 9
ESKE-.20	2,3	1,5	6 - 13
ESKE-.25	3,0	2,0	7 - 12 / 10 - 17
ESKE-.32	4,5	3,0	13 - 21
ESKE-.40	11,0	10,0	17 - 28
ESKE-.50	13,0	12,0	23 - 35
ESKE-.63	17,0	16,0	31 - 48

11. Efficiency table for IE3

Table 6: Efficiency in accordance with IE3.

Rated output power [kW]	Number of poles											
	2			4			6			8		
	100%	75%	50%	100%	75%	50%	100%	75%	50%	100%	75%	50%
0,25	-	-	-	73,6	71,2	65,4	68,6	64,5	58,4	64,1	59,4	51,6
0,37	75,2	72,9	66,6	77,3	74,5	70,2	73,5	70,0	64,3	69,3	65,6	59,2
0,55	78,7	78,8	77,2	80,8	79,4	75,1	77,2	74,7	69,9	73,0	70,4	65,5
0,75	81,1	81,4	79,3	82,6	82,6	80,0	78,9	77,3	74,9	75,0	72,8	69,4
1,1	83,3	84,3	83,3	84,1	81,5	78,1	81,0	79,5	77,2	77,7	75,7	72,6
1,5	85,1	86,1	85,6	85,3	84,9	82,2	82,5	81,1	78,9	79,7	77,9	75,0
2,2	85,9	86,8	86,4	86,7	85,7	84,0	84,3	83,0	81,0	81,9	80,3	77,7
3	87,1	87,1	85,7	87,7	87,2	85,6	85,6	84,4	82,5	83,5	82,0	79,7
4	88,1	86,3	83,7	89,2	88,7	86,2	86,8	85,6	83,9	84,8	83,5	81,4
5,5	89,8	87,5	84,3	90,3	91,1	90,1	88,0	86,9	85,3	86,2	84,9	83,0
7,5	90,1	89,8	88,5	90,6	90,6	89,1	89,1	88,1	86,5	87,3	86,3	84,5

Die nachfolgenden Richtlinien enthalten die wichtigsten Anleitungen für Montage und Wartung sowie Installation und Anwendung des Elektromotors nach IEC 364.

1. TRANSPORT UND LAGERUNG **WICHTIG !**

DIE MOTOREN SOLLEN IN GESCHLOSSENEN, TROCKENEN RÄUMEN GELAGERT WERDEN.

Bei Lagerung im Freien müssen sie gegen alle schädlichen Umwelteinflüsse geschützt werden. Beim Transport ist darauf zu achten, dass die üblichen Vorsichtsmaßnahmen eingehalten werden. Es muss sichergestellt sein, dass das Wellenende nicht durch Stöße oder Schläge axial oder radial beschädigt wird, wodurch auch das Kugellager und der Lagersitz Schaden nehmen können. Für den Transport sind die Hebekralen zu benutzen.

2. Ex- KENNZEICHNUNG

Mögliche Kennzeichnungen

 II 2G Ex db IIC T4 – T6 Gb

 II 2G Ex db IIB T4 – T6 Gb

oder

 II 2G Ex db eb IIC T4 – T6 Gb

 II 2G Ex db eb IIB T4 – T6 Gb

oder

 II 2 D Ex tb IIIC T135°C – 85°C Db

Ex db IIC T* Gb

Ex db IIB T* Gb

or

Ex db eb IIC T* Gb

Ex db eb T* Gb

or

Ex tb IIIC T*°C Db

 : Ex Symbol

II: Gerätegruppe II. Der Motor darf in explosionsgefährdeten Bereichen, außer im Bergbau, eingesetzt werden

2: Kategorie : Für Einsatz in Zone 1. Sehr sicher in gelegentlicher Ex-Atmosphäre ...

G: Ex-Atmosphäreverursacht durch Gas

D:verursacht durch Staub

db: Zündschutzart- Druckfeste Kapselung

eb: Zündschutzart- Erhöhte Sicherheit

tb: Staub Zündschutzart, Praxis A für den Einsatz in Zone 21

IIB: Explosionsgruppe IIB

IIC: Explosionsgruppe IIC

T4, T6: Temperatureklasse

T135°C – T85°C: maximale Oberflächentemperatur von Motoren

2.1 ERLAUBTER UMGEBUNGSTEMPERATUR BEREICH

ATEX:

Tabelle 1: Erlaubter umgebungst temperatur bereich (ATEX).

<u>Type of protection</u>	<u>Explosion group</u>	<u>Lower limit</u>	<u>Upper limit</u>
<u>Ex db</u>			
<u>Standard stator housing</u>	<i>IIC</i>	-50 °C	60 °C
	<i>IIB</i>	-50 °C	85 °C
<u>Extended stator housing FS71 – FS132</u>	<i>IIC</i>	-20 °C	60 °C
	<i>IIB</i>	-20 °C	85 °C
<u>Extended stator housing FS160 – FS225</u>	<i>IIC</i>	-50 °C	60 °C
	<i>IIB</i>	-50 °C	85 °C
<u>Ex db eb</u>	<i>IIB / IIC</i>	-20 °C	60 °C
<u>Ex tb</u>	<i>IIIC</i>	-30 °C	85 °C

IECEX:

Tabelle 2: Erlaubter umgebungst temperatur (IECEX).

<u>Type of protection</u>	<u>Explosion group</u>	<u>Lower limit</u>	<u>Upper limit</u>
<u>Ex db</u>			
<u>Standard stator housing</u>	<i>IIC</i>	-20 °C	60 °C
	<i>IIB</i>	-20 °C	60 °C
<u>Extended stator housing FS71 – FS132</u>	<i>IIC</i>	-20 °C	60 °C
	<i>IIB</i>	-20 °C	60 °C
<u>Extended stator housing FS160 – FS225</u>	<i>IIC</i>	-50 °C	60 °C
	<i>IIB</i>	-50 °C	60 °C
<u>Ex db eb</u>	<i>IIB / IIC</i>	-20 °C	60 °C
<u>Ex tb</u>	<i>IIIC</i>	-30 °C	85 °C

Der Standardtemperaturbereich der Motoren beträgt -20/+40°C.

SPEZIELLER ENTWURF

- Umgebungstemperatur max. -50°C, nur mit Ex d-Schutz
- Umgebungstemperatur über 40°C (max. 85°C – nur für Gasgruppe IIB)

2.1 EG Baumusterprüfbescheinigungsnummer

BVS 13 ATEX E 125 X

IECEX BVS 13.0121 X

X- Eine Reparatur an den zünddurchschlagsicheren Spalten darf nur entsprechend konstruktiven Vorgaben des Herstellers erfolgen. Die Reparatur entsprechend den Werten der Tabelle 1 und 2 der EN 60079-1 (IEC 60079-1) ist nicht zulässig.

3. ANWENDUNG UND EXPLOSIONSSCHUTZ

Drehstrom-Asynchronmotoren in explosions-geschützter Ausführung 4KTC sind für den Betrieb in Industriegebäuden bestimmt, wo die Gefahr der Explosion von brennbaren Gasen, Dämpfen, entzündbaren Flüssigkeiten oder brennbaren Stäuben besteht.

Die explosionsgeschützte Ausführung der Motoren ist folgende :

- Druckfeste Kapselung für das Gehäuse des Motors und "erhöhte Sicherheit" für den Anschlusskasten nach EN 60079-0 (IEC 60079-0), EN 60079-1 (IEC 60079-1) und 60079-7 (IEC 60079-7). Auf dem Deckel des Anschlußkastens steht die Bezeichnung Ex.
- Druckfeste Kapselung für das Gehäuse des Motors und für den Anschlusskasten nach EN 60079-0 (IEC 60079-0) und EN 60079-1 (IEC 60079-1). Auf dem Deckel des Anschlußkastens steht die Bezeichnung Ex.

- Schutz durch Gehäuse »tb« für das Motorgehäuse und den Anschlusskasten nach EN 60079-31 (IEC 60079-31) für den Einsatz in Bereichen mit brennbarem Staub.

Die Gehäuse der Elektromotoren sind für die Gasgruppe IIC ausgelegt.

Die Standardausführung der Elektromotoren entspricht der Temperaturklasse T4.

Die genaue Bezeichnung des Explosionsschutzes befindet sich auf dem Typenschild.

4. AUFSTELLUNG (MONTAGE) WICHTIG !

DIE MONTAGE DES ELEKTROMOTORS DARF NUR VON QUALIFIZIERTEM PERSONAL AUSGEFÜHRT WERDEN, UM EVENTUELLEN BESCHÄDIGUNGEN WÄHREND DES BETRIEBES WEGEN FALSCHER MONTAGE VORZUBEUGEN.

Bei der **Aufstellung** des Elektromotors muß man:

- Forderungen der Installationsvorschriften beachten.
- prüfen, ob der Explosionsschutz der Umgebung entspricht (Zone, Gasgruppe, Temperaturklasse).
- prüfen, wie die Umgebung auf den Betrieb des Elektromotors einwirkt (aggressive Umgebung, Temperatur, Staub, usw...).
- Lokale und Fabrikbesonderheiten und Forderungen berücksichtigen.
- die Verwendung von richtigen Werkzeugen und Vorrichtungen sicherstellen.
- Forderungen für sicheren Betrieb beachten.
- die Verwendung von persönlichen Schutzmitteln gewährleisten.

Bei der Montage (Aufstellung) des Elektromotors im Freien wird empfohlen, daß der Motor vor unmittelbarer Sonneneinstrahlung geschützt wird. Auf dem Elektromotor, der in senkrechter Lage betrieben wird, muß über den Öffnungen der Lüfterhaube ein Schutzdach angebracht sein, um vor Wassereindringen zu schützen.

Vor der Inbetriebnahme oder bei Verdacht auf erhöhte Feuchtigkeit ist der Isolationswiderstand zu prüfen.

Der Isolationswiderstand, gemessen bei 25°C, muss den Bezugswert von 100MΩ (gemessen mit 500 oder 1000 V DC) übersteigen. Für erhöhte Umgebungstemperaturen ist der Wert des Isolationswiderstandes für jeweils 20°C zu halbieren.

Wenn der Bezugswert nicht erreicht wird, ist die Feuchte innerhalb der Wicklung zu groß und eine Ofentrocknung wird erforderlich. Die Ofentemperatur sollte für 12-16 Stunden bei 90°C liegen, danach 6-8 Stunden bei 105°C.

Bei der Montage von Kupplung, Riemenscheibe und anderen Komponenten auf die Welle des Elektromotors muß ebenfalls beachtet werden, daß durch Schläge oder Stöße kein Schaden entsteht bzw. die explosionsgeschützte Ausführung des Motors nicht beeinträchtigt wird.

5. NETZANSCHLUß WICHTIG !!!

ANLAGEN IN EXPLOSIONSGESCHÜTZTER AUSFÜHRUNG DÜRFEN NUR FACHLICH QUALIFIZIERTE PERSONEN AN DAS NETZ MONTIEREN UND ANSCHLIEßEN, DIE ÜBER ENTSPRECHENDE KENNNTNISSE AUF DEM GEBIET DES EXPLOSIONSSCHUTZES VERFÜGEN !

Vor dem Anschließen des Elektromotors an das Netz muß noch folgendes geprüft werden :

- ob die Angaben auf dem Schild der Spannung und der Frequenz des Netzes entsprechen.
- ob der Explosionsschutz der Umgebung entspricht, in welcher der Elektromotor in Betrieb genommen wird (Gasgruppe, Temperaturklasse).
- ob die Installation (Rohre oder Kabel) richtig ausgeführt ist.

Die Elektromotoren drehen haben standardmässig rechtslauf , wenn die Phasenleiter L1, L2 und L3 an die Anschlüsse U, V, W (1U, 1V 1W bzw U1, V1, W1) angeschlossen werden. Die Veränderung der Drehrichtung erreicht man, wenn man die Anschlußstelle von zwei Zuleitungsphasenleitern wechselt. An die zusätzlichen Anschlussklemmen werden folgende Elemente angeschlossen:

10-11 oder 12-13	Kaltleiter 145°C eingebaut
14-15	Thermofühler NC (Öffner)
16-17	Thermofühler NO (Schliesser)

Die Motoren sind mit 3 Temperaturfühlern (Kaltleiter DIN 44081 - ...) ausgerüstet. Diese sind an ein Auslösegerät, mit dem Prüfzeichen von einer EG zugelassenen Prüfstelle ausgestellt, anzuschließen. Ist das Auslösegerät nicht explosionsgeschützt. Muss es außerhalb des explosionsgefährdeten Bereiches installieren werden. Durch das von einer EG zugelassene Prüfstelle ausgestellte Prüfzeichen wird nur die

Einhaltung der elektrischen Daten an der Schnittstelle zwischen Temperaturfühlerkreis und Auslösegerät bestätigt und die Anwendung des Auslösegerätes mit Prüfzeichen und Kaltleitertemperaturfühler gemäß DIN 44081 zur thermischen Überwachung explosionsgeschützter elektrischer Maschinen zugelassen.

Auf die Anschlußstellen 30-31 (230V) oder 32-33 (110V) werden die Stillstandsheizungen eingebaut. Motoren mit Stillstandsheizung sind durch ein Zusatzschild, aus dem die Nenndaten der Heizung ersichtlich sind, gekennzeichnet.

Durch die elektrische Steuerung ist sicherzustellen, daß die Motornennspannung und Heizspannung nicht gleichzeitig anliegen können.

Der Anschluß der Kabeladern auf die Anschlußplatte soll besonders sorgfältig ausgeführt werden. Die Isolierung der Kabeladern soll sich nahe der Anschlußstelle befinden, alle Drähte der feindrätigen Adern müssen an der Anschlußstelle eingespannt werden.

Das Anzugsmoment der Anschlüsse auf der Anschlußplatte ist maximal 7,5 Nm.

Bei der Ausführung des Explosionsschutzes des Kastens Exd ("druckfeste Kapselung") sind verbindlich die Installationsvorschriften zu beachten und der richtige Explosionsschutz an der Kabeleinführung (Exd Einführung) muß gesichert werden.

Vor dem Netzanschluß ist im Anschlußkasten folgendes zu kontrollieren :

- daß sich im Inneren des Anschlußkastens kein Staub, Reste der Drähte und ähnliches befindet,
- daß die elektrischen Verbindungen ordnungsgemäß ausgeführt sind und daß die Schrauben entsprechend befestigt sind,
- daß die luftstrecke der Spannung 400V oder bei 630V minimal 10 mm beträgt,
- daß die nicht verwendbaren Drähte getrennt und entsprechend befestigt sind,
- Alle Spalte sind gleichmäßig mit Fett Typ für PD-2 (Setral MI PD LL/2A) oder Renolit RHF-1 Fuchs gefettet
- daß die anliegenden Flächen gereinigt und mit einem säurefreien Fett leicht angeschmiert werden,
- daß das Kabel richtig an der Einführung abgedichtet wird.
- daß die nicht benutzten Öffnungen geschlossen werden, so daß die druckfesten genschaften erhalten bleiben. Die vorgesehenen Mittel um dieses Ziel zu erreichen müssen gewährleisten, daß man die Verschlussstopfen nur mit Hilfe eines Werkzeuges entfernen kann.

6. SCHUTZ DER ELEKTROMOTOREN IM BETRIEB WICHTIG !

Nach der Aufstellung des Elektromotors müssen alle rotierenden Teile vor Berührung gesichert werden.

Nur qualifiziertes Personal darf die Maschinen betätigen !

In der S1-Betriebsart reicht der Motorschutzschalter als alleinige Maßnahme zur Einhaltung der Temperaturklasse aus. Dazu muß er auf den Bemessungsstrom des Drehstrommotors eingestellt werden.

In den S2- bis S3 Betriebsarten und bei Umrichterbetrieb müssen die Drehstrommotoren mit je 3 in der Wicklung untergebrachten PTC's nach DIN 44080, DIN 44081 bzw. DIN 44082 ausgestattet werden. Die Nennabschalttemperatur dieser PTC's beträgt 145°C. Ein entsprechendes Auslösegerät das ein Prüfzeichen der PTB (Lab. 3.43) besitzt, vervollständigt die Schutzeinrichtung zur Einhaltung der Temperaturklasse.

Elektromotoren mit mehreren Geschwindigkeiten (zwei getrennte Wicklungen oder eine Wicklung mit Dahlanderschaltung) müssen für jede Geschwindigkeit separat geschützt werden.

Das Gehäuse des Elektromotors muß mit dem Schutzleiter verbunden werden und geerdet sein. Im Anschlußkasten befindet sich die Schraube für den Anschluß des Schutzleiters und auf dem Gehäuse des Stators ist die Schraube für die Erdung.

Falls der Elektromotor über den Frequenzumformer gespeist wird, muß man prüfen, daß die Einstellung des Umformers dem deklarierten Bereich auf dem Schild entspricht. Der Elektromotor muß doppelt geschützt sein, das bedeutet, mit dem Motorschutzschalter und mit dem Temperaturschutz. Das Auslösegerät, das mit dem Temperaturschutz verbunden ist, muß sich im Bereich von $2\text{ k}\Omega < R_o < 4\text{ k}\Omega$ befinden, wobei R_o den Ausschaltwiderstand darstellt. Das Ausschaltgerät muß das Prüfzeichen tragen.

7. WARTUNG

Elektromotoren haben eine robuste Konstruktion und verlangen keine besondere Wartung.

In regelmäßigen Zeitabschnitten (abhängig von der Umgebung) muß der Motor gereinigt werden, insbesondere die Eintrittsöffnungen auf der Lüfterhaube, so daß eine ausreichende Luftzufuhr für die Kühlung gewährleistet wird.

Elektromotoren sind mit geschlossenen dauergeschmierten Lagern versehen. Die Lebensdauer der Lager beträgt 20000 Betriebsstunden von zweipoligen Elektromotoren ($n_s=3000 \text{ min}^{-1}$) bei normalen Betriebsbedingungen oder 40000 Betriebsstunden von vier- und Mehrpoligen Motoren.

Regelmäßige Inspektionen und Kontrollmessungen, die vom Personal ausgeführt werden, das für solche Arbeiten qualifiziert ist, sind Maßnahmen, wodurch mögliche Schäden und Betriebsunterbrechungen vermindert werden.

Jede Abweichung von den Nennwerten (höherer Betriebsstrom, erhöhte Temperatur, Vibrationen, ungewöhnlicher Lärm oder Geruch, reagieren von Schutz-Kontrollanlagen usw.) ist ein Zeichen, daß etwas mit dem Betrieb nicht in Ordnung ist !

Um größere Schäden zu verhindern, die unmittelbar oder mittelbar zu weiterem Schaden bei Personen oder Materialgütern führen könnten, ist sofort die verantwortliche Person zu benachrichtigen.

8. REPARATUREN WICHTIG !

ELEKTROMOTOREN IN EXPLOSIONSGE-SCHÜTZTER AUSFÜHRUNG DARF NUR DER HERSTELLER ODER DIE BEVOLL-MÄCHTIGTE WERKSTATT REPARIEREN ! ! ! PERSONEN, DIE EX-APPARATE AUSEINAN-DERNEHMEN UND REPARIEREN, MÜSSEN FACHLICH QUALIFIZIERT SEIN, ÜBER EINE ZUSÄTZLICHE KENNTNIS AUF DEM GEBIET DES EXPLOSIONSSCHUTZES VERFÜGEN UND DIE ARBEIT MUSS VON EINEM EX- SACHVERSTÄNDIGEN BEGUTACHTET UND ZERTIFIZIERT WERDEN.

Repare nach der druckfesten Spalten nach Tabelle 2 der EN 60079-1 ist nicht zulässig!

Von der Montage des Elektromotors müssen alle druckfesten Spalte und Fugen gereinigt und mit Fett Typ PD-2 (Setral MI PD LL/2) oder Renolit RHF-1 gefettet werden.

Beim Auseinandernehmen von Elektromotoren muß man darauf achten, daß die Oberflächen nicht beschädigt werden, welche die Ex Schutzspalte bilden ! Bei der Reparatur des Elektromotors müssen alle Bestandteile der, seitens PTB bestätigter Dokumentation entsprechen.

Falls bei der Reparatur festgestellt wird, daß die "druckfeste Kapselung" nicht mehr den Forderungen des Explosionsschutzes und den Forderungen im Zertifikat entspricht, muß von diesem Motor das Zeichen des Explosionsschutzes beseitigt werden.

9. SCHRAUBENVERBINDUNGEN

Tabelle 3: Anzugsdrehmomente für Schrauben der Festigkeitsklasse 8.8 und A4-70 (A4-80) nur in Bauteilen mit höherer Festigkeit (z. B. Grauguss, Stahl) verwenden.

Gewinde	Anzugsdrehmoment (Nm)	Gewinde	Anzugsdrehmoment (Nm)
M4	2.3	M12	66
M5	4.6	M14	105
M6	7.9	M16	160
M8	19	M20	330
M10	38	M24	560

Tabelle 4: Schraubenverbindungen für elektrische Anschlüsse .

Gewinde	Anzugsdrehmoment (Nm)	Gewinde	Anzugsdrehmoment (Nm)
M4	1.2	M10	10
M5	2	M12	15.5
M6	3	M16	30
M8	6	M20	52

10. EMPFOHLENE DREHMOMENT FÜR BARTEC VARNOST STANDARD Ex e KABELVERSCHRAUBUNGEN (Nm)

Tabelle 5: Empfohlenes Anzugsmoment und Terminal Größen für Kabelverschraubungen WISKA, Typ. ESKE-...

Kabelverschraubungen	Anschlussgewinde (Nm)	Befestigen (Nm)	Mutter;	Kabeldurchmesser (mm)
ESKE-.12	2,0	2,0		3 - 6
ESKE-.16	1,8	1,3		4 - 9
ESKE-.20	2,3	1,5		6 - 13
ESKE-.25	3,0	2,0		7 - 12 / 10 - 17
ESKE-.32	4,5	3,0		13 - 21
ESKE-.40	11,0	10,0		17 - 28
ESKE-.50	13,0	12,0		23 - 35
ESKE-.63	17,0	16,0		31 - 48

11. Wirkungsgradtabelle nach IE3

Tabelle 6: Erträge nach IE3.

Nennleistung [kW]	Anzahl del pole											
	2			4			6			8		
	100%	75%	50%	100%	75%	50%	100%	75%	50%	100%	75%	50%
0,25	-	-	-	73,6	71,2	65,4	68,6	64,5	58,4	64,1	59,4	51,6
0,37	75,2	72,9	66,6	77,3	74,5	70,2	73,5	70,0	64,3	69,3	65,6	59,2
0,55	78,7	78,8	77,2	80,8	79,4	75,1	77,2	74,7	69,9	73,0	70,4	65,5
0,75	81,1	81,4	79,3	82,6	82,6	80,0	78,9	77,3	74,9	75,0	72,8	69,4
1,1	83,3	84,3	83,3	84,1	81,5	78,1	81,0	79,5	77,2	77,7	75,7	72,6
1,5	85,1	86,1	85,6	85,3	84,9	82,2	82,5	81,1	78,9	79,7	77,9	75,0
2,2	85,9	86,8	86,4	86,7	85,7	84,0	84,3	83,0	81,0	81,9	80,3	77,7
3	87,1	87,1	85,7	87,7	87,2	85,6	85,6	84,4	82,5	83,5	82,0	79,7
4	88,1	86,3	83,7	89,2	88,7	86,2	86,8	85,6	83,9	84,8	83,5	81,4
5,5	89,8	87,5	84,3	90,3	91,1	90,1	88,0	86,9	85,3	86,2	84,9	83,0
7,5	90,1	89,8	88,5	90,6	90,6	89,1	89,1	88,1	86,5	87,3	86,3	84,5

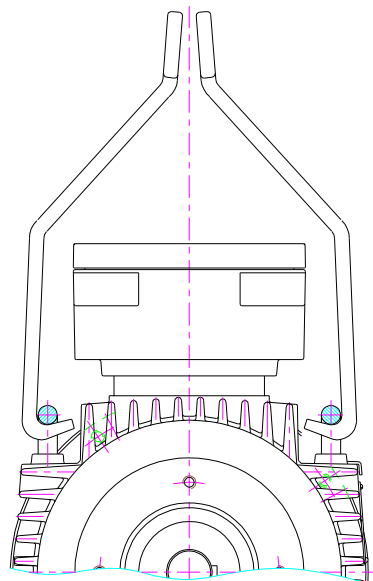

IM V1

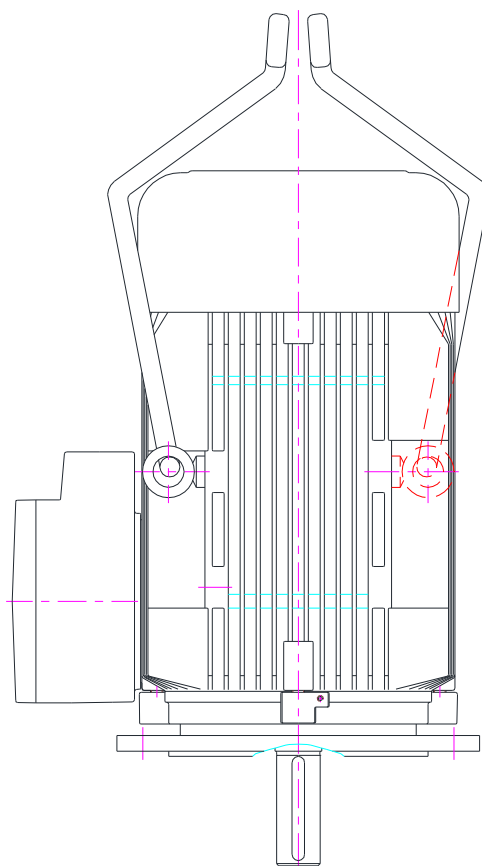

VEZNA SHEMA / ANSCHLUSSSCHALTBILD / CONNECTION DIAGRAM

PRIKLJUČNA OMARICA / TERMINAL BOX

Ex d, Ex de 4KTC

<p>Y-ZAGON Y-SCHALTUNG Y-START</p> <p>Δ-ZAGON Δ-SCHALTUNG Δ-START</p> <p>ENOHITROSTNI/ EINTOURING/ ONE SPEED</p>			
<p>NIŽJA HITROST NIEDRIGE DREHZAHL LOW SPEED</p> <p>VIŠJA HITROST HOHE DREHZAHL HIGH SPEED</p> <p>POLNOPREKLOPNI/ PULMSCHALTBAR/ POLE-CHANGING WINDING</p>			
<p>NIŽJA HITROST NIEDRIGE DREHZAHL LOW SPEED</p> <p>VIŠJA HITROST HOHE DREHZAHL HIGH SPEED</p> <p>DAHLANDER-VEZAVA/ DAHLANDER-SCHALTUNG/POLE-CHANGING WINDING (DAHLANDER)</p>			
<p>NIŽJA HITROST NIEDRIGE DREHZAHL LOW SPEED</p> <p>VIŠJA HITROST HOHE DREHZAHL HIGH SPEED</p> <p>DAHLANDER-VEZAVA/ DAHLANDER-SCHALTUNG/POLE-CHANGING WINDING (DAHLANDER)</p>			
10 - 11	TEMPERATURNO TIPALO KALTLEITER ABSCHALTUNG THERMISTORS	OPOZORILNO TIPALO KALTLEITER VORWARNUNG EARLY WARNING	ODKLOPNA NAPRAVA S PTB - ŠTEVILKO AUSLOSEGERAT MIT PTB - NUMMER SHOUT - DOWN - DEVICE WITH PTB - NUMBER
12 - 13	NAJVIŠJA DELOVNA NAPETOST MAXIMALE BETRIEBSSPANNUNG MAKSIMUM OPERATING VOLTAGE 25V	IZKLOPNO TIPALO KALTLEITER ABSCHALTUNG THERMISTORS - OVER LOAD	
14 - 15	TEMPERATURNO STIKALO THERMOSTATE THERMOSTATS	NC ODPIRAJOČ OFFNER CONTACT NORMALLY CLOSED	
16 - 17	TEMPERATURNO STIKALO THERMOSTATE THERMOSTATS 250V	NO ZAPIRAJOČ SCHLIESSER CONTACT NORMALLY OPEN	
20 21 22 23	TIPALO PT 100 WIDERSTANDSTEMPERATURFUHLER PT 100 THERMOSTATS PT 100		
30 - 31	GRELICI - PRIKLJUČNA NAPETOST STILLSTANDSHEIZUNG - BETREIBSSPANNUNG	220V - 240V	
32 - 33	HEATERS - RATED VOLTAGE	110V	

Translation

EU-Type Examination Certificate Supplement 2

Change to Directive 2014/34/EU

Equipment intended for use in potentially explosive atmospheres
Directive 2014/34/EU

EU-Type Examination Certificate Number: **BVS 13 ATEX E 125 X**

Product: **Flameproof electric motors type 4 KT** *** ** ** ***

Manufacturer: **BARTEC VARNOST, d.o.o.**

Address: **Cesta 9. avgusta 59, 1410 Zagorje ob Savi, Slovenia**

This supplementary certificate extends EC-Type Examination Certificate No. BVS 13 ATEX E 125 X to apply to products designed and constructed in accordance with the specification set out in the appendix of the said certificate but having any acceptable variations specified in the appendix to this certificate and the documents referred to therein.

DEKRA Testing and Certification GmbH, Notified Body number 0158, in accordance with Article 17 of Directive 2014/34/EU of the European Parliament and of the Council, dated 26 February 2014, certifies that this product has been found to comply with the Essential Health and Safety Requirements relating to the design and construction of products intended for use in potentially explosive atmospheres given in Annex II to the Directive.

The examination and test results are recorded in the confidential Report No. BVS PP 14.2052 EU.

The Essential Health and Safety Requirements are assured in consideration of

EN IEC 60079-0:2018	General requirements
EN 60079-1:2014	Flameproof enclosure "d"
EN IEC 60079-7:2015 + A1:2018	Increased Safety "e"
EN 60079-31:2014	Protection by Enclosure "t"

If the sign "X" is placed after the certificate number, it indicates that the product is subject to the Special Conditions for Use specified in the appendix to this certificate.

This EU-Type Examination Certificate relates only to the design and construction of the specified product. Further requirements of the Directive apply to the manufacturing process and supply of this product. These are not covered by this certificate.

The marking of the product shall include the following.

	II 2G Ex db IIC T* Gb	or	Ex db eb IIC T* Gb	or
	II 2G Ex db IIB T* Gb	or	Ex db eb IIB T* Gb	or
	II 2D Ex tb IIIC T**C Db			

* See clause "Parameters"

DEKRA Testing and Certification GmbH
Bochum, 2021-05-19

Signed: Jörg-Timm Kilisch

Managing Director



Page 1 of 5 of BVS 13 ATEX E 125 X / N2 - Jobnumber 342010000
This certificate may only be reproduced in its entirety and without any change.

DEKRA Testing and Certification GmbH, Handwerkstr. 15, 70565 Stuttgart, Germany
Certification body, Dinnendahlstr. 9, 44809 Bochum, Germany
Phone +49 234 3696-400, Fax +49 234 3696-401, e-mail DTC-Certification-body@dekra.com

13 **Appendix**
 14 **EU-Type Examination Certificate**

**BVS 13 ATEX E 125 X
 Supplement 2**

15 **Product description**

15.1 **Subject and type**

Flameproof electric motors type 4 KT** *** ** */*

Type designation to 4 KT*(1)*(2) *(3)*(3)*(3) *(4)*(4)*(4) *(5)*(5) *(5)/(6)

Explosion Group:

- 1): B: Flameproof enclosure for Group IIB
 C: Flameproof enclosure for Group IIC
- 2): D: Applicable in the presence of combustible dust group IIIC

3): Frame size

71	71 mm
80	80 mm
90	90 mm
100	100 mm
112	112 mm
132	132 mm
160	160 mm
180	180 mm
200	200 mm
225	225 mm

- 4): IE3 – IE3 version of motors (optional)
- 5): Length of stator assembly
- 6): Number of poles

15.2 **Description**

With this supplement the certificate is changed to Directive 2014/34/EU.
 (Annotation: In accordance with Article 41 of Directive 2014/34/EU, EC-Type Examination Certificates referring to 94/9/EC that were in existence prior to the date of application of 2014/34/EU (20 April 2016) may be referenced as if they were issued in accordance with Directive 2014/34/EU. Supplementary Certificates to such EC-Type Examination Certificates, and new issues of such certificates, may continue to bear the original certificate number issued prior to 20 April 2016.)

Reason for the supplement:

- Change to Directive 2014/34/EU
- Updating to the current version of standards; therefore the marking of the devices will be modified.
- Further motor variants added, type designation extended accordingly
- Larger terminal box for motor sizes 180 – 225 removed



Description of Product

The enclosure of the flameproof electric motor is made of cast iron and has a mounting place for terminal boxes.

The shaft will be fixed with ball bearings.

The shaft sealing of the flameproof electric motor is realised by non-metallic sealing rings made of for use in areas requiring EPL Db.

A terminal compartment in type of protection Flameproof Enclosure "d", Increased Safety "e" or Protection by Enclosure "tb" or a direct cable entry is used for electrical connection of the motor. For electric power input into the motor compartment, separately certified cable glands or line bushings are used.

The cooling of the motor is realised by an external fan that is made of steel, aluminium or plastic. The fan can be driven by the electrical machine itself or by a separately certified forced ventilation motor.

Optionally a space heater can be mounted inside the stator housing.

For direct temperature monitoring the winding of the motor is equipped with temperature sensors (thermistors according DIN 44081 or DIN 44082). The sensors are connected in series. Optionally the temperature monitoring of the winding can be realised by thermal switches / bimetal switches.

Optionally the temperature at the bearings could be monitored separately certified resistance thermometers (Pt100).

The sensors respectively the thermometers shall be connected to a trigger unit which is certified for this purpose.

The maximum permissible ambient temperatures are -50 °C to 85 °C. This temperature range may be limited as a result of the selected terminal boxes and components, or the electrical design.

15.3 Parameters

15.3.1 Electrical parameters

Circuits of the flameproof electric motors

Rated voltage

Frame size 71 - 225	up to	690	V AC
Rated rotational speed	500	up to	3600 min ⁻¹
Rated rotational speed (with converter)	48	up to	6000 min ⁻¹
Frequency (mains)			50 / 60 Hz
Frequency (converter)			
Frame size 71 - 160	5	up to	100 Hz
Frame size 180 - 225	5	up to	87 Hz
Duty type	S1	up to	S9

Rated power

Frame size		50 Hz	60 Hz
71	up to	0.55 kW	0.66 kW
80	up to	1.1 kW	1.3 kW
90	up to	2.2 kW	2.6 kW
100	up to	3 kW	3.6 kW
112	up to	4 kW	4.8 kW
132	up to	7.5 kW	9 kW
160	up to	18.5 kW	21 kW
180	up to	22 kW	26 kW
200	up to	37 kW	42 kW
225	up to	45.5 kW	52 kW

Monitoring circuits

Temperature sensors
(ptc thermistors)

According to the specifications given in the certificate of the trigger unit and the electrical design.

Circuits of the resistance thermometer
(Pt100)

According to the specifications given in the test report of the respective electrical design.

Bimetal switch

According to the specifications given in the test report of the respective electrical design.

15.3.2 Thermal ratings

Type of protection	Explosion Group	Lower limit	Upper limit
Ex db			
Standard stator housing	IIC	-50 °C	60 °C
	IIB	-50 °C	85 °C
Extended stator housing FS71 – FS132	IIC	-20 °C	60 °C
	IIB	-20 °C	85 °C
Extended stator housing FS160 – FS225	IIC	-50 °C	60 °C
	IIB	-50 °C	85 °C
Ex db eb	IIB / IIC	-20 °C	60 °C
Ex tb	IIIC	-30 °C	85 °C

The stated ambient temperature ranges may be limited as a result of the selected terminal box, components, sealing materials or by the electrical ratings.

The permissible ambient temperature range is marked on the name plate.

Ambient temperature range, temperature class and surface temperature

The electrical data, the temperature class, the surface temperature and the ambient temperature range of the respective version is determined by a routine test carried out by the manufacturer.

16 Report Number

BVS PP 14.2052 EU, as of 2021-05-19

17 Special Conditions for Use

The lengths of the flameproof joints are in parts longer and the gaps of the flameproof joints are in parts smaller than the values of table 3 of EN 60079-1:2014. For information of the dimensions of the flameproof joints contact the manufacturer.

Fasteners with a minimum yield stress of 640 N/mm² must be used for the closing of the flameproof enclosure.

Motors which have to be equipped with a direct temperature control must be monitored by a separate certified trigger unit.

If the electrical machine will be cooled by forced ventilation, it has to be assured that the electrical machine can only run if the ventilation is running

18 **Essential Health and Safety Requirements**

The Essential Health and Safety Requirements are covered by the standards listed under item 9.

19 **Drawings and Documents**

Drawings and documents are listed in the confidential report.

We confirm the correctness of the translation from the German original.
In the case of arbitration only the German wording shall be valid and binding.

DEKRA Testing and Certification GmbH
Bochum, 2021-05-19
BVS-Hh/Mu A20200764



Managing Director



IECEX Certificate of Conformity

INTERNATIONAL ELECTROTECHNICAL COMMISSION IEC Certification System for Explosive Atmospheres

for rules and details of the IECEx Scheme visit www.iecex.com

Certificate No.:	IECEX BVS 13.0121X	Page 1 of 6	<u>Certificate history:</u>
Status:	Current	Issue No: 2	Issue 1 (2016-01-12) Issue 0 (2014-04-03)
Date of Issue:	2021-05-27		
Applicant:	BARTEC VARNOST, d.o.o. Cesta 9. avgusta 59 1410 Zagorje ob Savi Slovenia		
Equipment:	Flameproof electric motors type 4 KT** *** ** ** *		
Optional accessory:			
Type of Protection:	Flameproof Enclosures "d"; Protection by Enclosure "T"; Increased Safety "e"		
Marking:	Ex db IIC T* Gb or Ex db eb IIC T* Gb or Ex db IIB T* Gb or Ex db eb IIB T* Gb or Ex tb IIC T**C Db * See General product information "Parameters"		

Approved for issue on behalf of the IECEx
Certification Body:

Jörg Koch

Position:

Head of Certification Body

Signature:
(for printed version)

Date:

27.05.2021

1. This certificate and schedule may only be reproduced in full.
2. This certificate is not transferable and remains the property of the issuing body.
3. The Status and authenticity of this certificate may be verified by visiting www.iecex.com or use of this QR Code.



Certificate issued by:

DEKRA Testing and Certification GmbH
Certification Body
Dinnendahlstrasse 9
44809 Bochum
Germany

 **DEKRA**
On the safe side.



IECEX Certificate of Conformity

Certificate No.: **IECEX BVS 13.0121X**

Page 2 of 6

Date of issue: 2021-05-27

Issue No: 2

Manufacturer: **BARTEC VARNOST, d.o.o.**
Cesta 9. avgusta 59
1410 Zagorje ob Savi
Slovenia

Additional
manufacturing
locations:

This certificate is issued as verification that a sample(s), representative of production, was assessed and tested and found to comply with the IEC Standard list below and that the manufacturer's quality system, relating to the Ex products covered by this certificate, was assessed and found to comply with the IECEX Quality system requirements. This certificate is granted subject to the conditions as set out in IECEX Scheme Rules, IECEX 02 and Operational Documents as amended

STANDARDS :

The equipment and any acceptable variations to it specified in the schedule of this certificate and the identified documents, was found to comply with the following standards

IEC 60079-0:2017 Explosive atmospheres - Part 0: Equipment - General requirements
Edition:7.0

IEC 60079-1:2014-06 Explosive atmospheres - Part 1: Equipment protection by flameproof enclosures "d"
Edition:7.0

IEC 60079-31:2013 Explosive atmospheres - Part 31: Equipment dust ignition protection by enclosure "t"
Edition:2

IEC 60079-7:2017 Explosive atmospheres - Part 7: Equipment protection by increased safety "e"
Edition:5.1

This Certificate **does not** indicate compliance with safety and performance requirements other than those expressly included in the Standards listed above.

TEST & ASSESSMENT REPORTS:

A sample(s) of the equipment listed has successfully met the examination and test requirements as recorded in:

Test Report:

[DE/BVS/ExTR14.0033/02](#)

Quality Assessment Report:

[SI/SIQ/QAR11.0003/06](#)



IECEx Certificate of Conformity

Certificate No.: **IECEx BVS 13.0121X**

Page 3 of 6

Date of issue: 2021-05-27

Issue No: 2

EQUIPMENT:

Equipment and systems covered by this Certificate are as follows:

Subject and Type

See Annex

Description

The enclosure of the flameproof electric motor is made of cast iron and has a mounting place for terminal boxes.

The shaft will be fixed with ball bearings.

The shaft sealing of the flameproof electric motor is realised by non-metallic sealing rings made of for use in areas requiring EPL Db.

A terminal compartment in type of protection Flameproof Enclosure "d", Increased Safety "e" or Protection by Enclosure "tb" or a direct cable entry is used for electrical connection of the motor. For electric power input into the motor compartment, separately certified cable glands or line bushings are used.

The cooling of the motor is realised by an external fan that is made of steel, aluminium or plastic. The fan can be driven by the electrical machine itself or by a separately certified forced ventilation motor.

Optionally a space heater can be mounted inside the stator housing.

For direct temperature monitoring the winding of the motor is equipped with temperature sensors (thermistors according DIN 44081 or DIN 44082). The sensors are connected in series. Optionally the temperature monitoring of the winding can be realised by thermal switches/ bimetal switches.

Optionally the temperature at the bearings could be monitored separately certified resistance thermometers (Pt100).

The sensors respectively the thermometers shall be connected to a trigger unit which is certified for this purpose.

The maximum permissible ambient temperatures are -50 °C to 85 °C. This temperature range may be limited as a result of the selected terminal boxes and components, or the electrical design.

SPECIFIC CONDITIONS OF USE: YES as shown below:

The lengths of the flameproof joints are in parts longer and the gaps of the flameproof joints are in parts smaller than the values of table 3 of IEC 60079-1:2014. For information of the dimensions of the flameproof joints contact the manufacturer.

Fasteners with a minimum yield stress of 640 N/mm² must be used for the closing of the flameproof enclosure.

Motors which have to be equipped with a direct temperature control must be monitored by a separate certified trigger unit.

If the electrical machine will be cooled by forced ventilation, it has to be assured that the electrical machine can only run if the ventilation is running.



IECEX Certificate of Conformity

Certificate No.: **IECEX BVS 13.0121X**

Page 4 of 6

Date of issue: 2021-05-27

Issue No: 2

Equipment (continued):

Listing of all components used referring to older standards

Subject and type	Certificate	Standards
Connecting Terminal Type 07-9702-0*2)****	¹ IECEX PTB 07.0007U, issue 2	IEC 60079-0:2011, Ed. 6.0 IEC 60079-7:2015, Ed. 5.0

¹ No applicable technical differences

² Technical differences evaluated and found satisfactory

Parameters

Electrical parameters

Circuits of the flameproof electric motors

Rated voltage

Frame size 71 - 225	up to	690	V AC
Rated rotational speed	500	up to	3600 min ⁻¹
Rated rotational speed (with converter)	48	up to	6000 min ⁻¹
Frequency (mains)		50 / 60	Hz
Frequency (converter)			
Frame size 71 - 160	5	up to	100 Hz
Frame size 180 - 225	5	up to	87 Hz
Duty type	S1	up to	S9

Rated power

Frame size		50 Hz		60 Hz	
71	up to	0.55	kW	0.66	kW
80	up to	1.1	kW	1.3	kW
90	up to	2.2	kW	2.6	kW
100	up to	3	kW	3.6	kW
112	up to	4	kW	4.8	kW
132	up to	7.5	kW	9	kW
160	up to	18.5	kW	21	kW
180	up to	22	kW	26	kW
200	up to	37	kW	42	kW
225	up to	45.5	kW	52	kW

Monitoring circuits

Temperature sensors
(pTC thermistors)

According to the specifications given in the certificate of the trigger unit and the electrical design.

Circuits of the resistance thermometer (Pt100)

According to the specifications given in the test report of the respective electrical design.

Bimetal switch

According to the specifications given in the test report of the respective electrical design.



IECEx Certificate of Conformity

Certificate No.: **IECEx BVS 13.0121X**

Page 5 of 6

Date of issue: 2021-05-27

Issue No: 2

Thermal ratings

Type of protection	Explosion Group	Lower limit	Upper limit
Ex db			
Standard stator housing	IIC	-20 °C	60 °C
	IIB	-20 °C	60 °C
Extended stator housing FS71 – FS132	IIC	-20 °C	60 °C
	IIB	-20 °C	60 °C
Extended stator housing FS160 – FS225	IIC	-50 °C	60 °C
	IIB	-50 °C	60 °C
Ex db eb	IIB / IIC	-20 °C	60 °C
Ex tb	IIIC	-30 °C	85 °C

The stated ambient temperature ranges may be limited as a result of the selected terminal box, components, sealing materials or by the electrical ratings.

The permissible ambient temperature range is marked on the name plate.

Ambient temperature range, temperature class and surface temperature

The electrical data, the temperature class, the surface temperature and the ambient temperature range of the respective version is determined by a routine test carried out by the manufacturer.



IECEX Certificate of Conformity

Certificate No.: **IECEX BVS 13.0121X**

Page 6 of 6

Date of issue: 2021-05-27

Issue No: 2

DETAILS OF CERTIFICATE CHANGES (for issues 1 and above)

- Updating to the current version of standards, therefore the marking of the devices will be modified
- Further motor variants added, type designation extended accordingly
- Larger terminal box for motor sizes 180 – 225 removed

Annex:

[BVS_13_0121X_Bartec_Varnost_issue2_Annex.pdf](#)



IECEx Certificate of Conformity



Certificate No.:

IECEx BVS 13.0121X issue No: 2

Annex

Page 1 of 1

Subject and Type

Flameproof electric motors type 4 KT** *** ** */*

Type designation to 4 KT*¹*(²) *³*(³)*³ *⁴*(⁴)*⁴ *⁵*(⁵) *⁶*(⁶)

Explosion Group:

- 1): B: Flameproof enclosure for Group IIB
 C: Flameproof enclosure for Group IIC
- 2): D: Applicable in the presence of combustible dust group IIIC

3): Frame size

71	71 mm
80	80 mm
90	90 mm
100	100 mm
112	112 mm
132	132 mm
160	160 mm
180	180 mm
200	200 mm
225	225 mm

4): IE3 – IE3 version of motors (optional)

5): Length of stator assembly





6): Number of poles

EU Declaration of Conformity

The Manufacturer:

BARTEC VARNOST d.o.o.
Cesta 9. Avgusta 59
1410 Zagorje ob Savi
Slovenia

declares under the sole responsibility that the products: 3-phase induction motors

Marking	Motor type	EU-Type Examination Certificate
II 2 G Ex db IIC T* Gb or 	4KTC 71 - 225	BVS 13 ATEX E 125 X Supplement 2
II 2 G Ex db eb IIC T* Gb 	4KTC 71 - 225	
II 2 D Ex tb IIIC T**C Db 	4KTCD 71-225	
II 2 G Ex db IIB T* Gb or 	4KTB 71 - 225	

Notified Body (ExNB): 0158, DEKRA Testing and Certification GmbH, Dinnendahlstrasse 9, 44809 Bochum, Germany

are in conformity with provisions of the following Union harmonization legislation:

Directive 2014/34/EU

and with the following standards:

EN 60079-0:2018, EN 60079-1:2014, EN 60079-7:2015 + A1:2018, EN 60079-31:2014 and relevant parts of the EN 60034-series of standards.

Directive 2009/125/EC

The motors are in conformity with the requirements set in the Commission Regulation EU 2019/1781 of 25 October 2019 and amendment EU 2021/341 of 26 February 2021 from 1st of July and onwards.

Standards which are applied are EN 60034-2-1:2014 and EN 60034-30-1.

According to the Regulation (EU) 2019/1781 (Article 2, 2m), motors placed on the market before 1 July 2029 as substitutes for identical motors integrated in products placed on the market before 1 July 2021, and specifically marketed as such, are exempt from the efficiency requirements.

Directive 2011/65/EU and with the amending Annex II to this Directive of the Delegated Directive (EU) 2015/863 on the restriction of the use of certain hazardous substances in electrical and electronic equipment. Technical documentation based on EN IEC 63000:2018

The indicated product is intended for fitting into a machine. The conformity of the end product according to the Directive 2006/42/EC has to be established by the commissioning party when the motor is fitted to the machinery.

Note: When installing motors for converter supply applications additional requirements must be respected regarding the motor as well as the installation.

The sign »X« placed after the certificate number indicates that the repair of the flameproof joints with the values in table 3 of EN 60079-1:2014 is not accepted and that the equipment is subject to special conditions for safe use which are prescribed in the manual.

Motors which have to be equipped with a direct temperature control must be monitored by a separately certified trigger unit.

If the electrical machine will be cooled by forced ventilation, it has to be assured that the electrical machine can only run if the ventilation is running.

Date: 28.05.2021

Signed by



Title

Janez Gajski
OM / ATEX Representative

BARTEC VARNOST d.o.o.
Cesta 9. Avgusta 59
1410 Zagorje ob Savi, SLOVENIJA

Telefon: +386 59 221 402
Telefax: +386 59 221 400
E-mail: info@Bartec-Varnost.si

UVOD

Bartec Varnost je zavezana k spoštovanju okoljske politike. V Bartec Varnost neprenehoma skrbimo, da so izdelki okolju prijazni in pri načrtovanju upoštevamo njihovo življenjsko dobo in način predelave po njenem izteku. Izdelki, izdelovalni procesi ter tudi logistika so načrtovani tako, da upoštevajo okoljske vidike. Bartec Varnost ima vzpostavljen sistem varovanja okolja, certificiran po standardu ISO 14001, ki je učinkovito orodje pri varovanju okolja.

Priložena navodila služijo kot priporočila za okolju prijazno reciklažo po izteku življenjske dobe. Dolžnost kupca je, da upošteva zahteve zakonodaje v državi uporabnika. Navodila ne vsebujejo vseh zahtev strank, zato je potrebno pridobiti dodatno dokumentacijo v projektni dokumentaciji.

MATERIALI, KI JIH VSEBUJE STANDARDNI ELEKTROMOTOR

Materiali, ki jih vsebuje standardni elektromotor so:

	Ohišja iz jeklene litine	Ohišja iz varjene jeklene pločevine
Jeklo	46%	82%
Baker	16%	11%
Jeklena litina	31%	1%
Materiali za izolacijo	3%	3%
Drugo	4%	3%

RECIKLAŽA MATERIALOV ZA EMBALAŽO

Takoj, ko izdelek pride na mesto vgradnje, je potrebno odstraniti material, ki služi za embalažo.

- Vse dele iz lesa je mogoče sežgati,
- Za nekatere države je potrebno embalažo za transport z ladjo izdelati iz impregniranega lesa, ki ga je potrebno reciklirati glede na zahteve zakonodaje v državi uporabnika,
- Materiale iz plastike je mogoče reciklirati,
- Zaščito pred korozijo s katero je zaščiten izdelek med transportom, je potrebno odstraniti z razmastili in čistilnimi krpami. Onesnažene čistilne krpe je potrebno odstraniti glede na zahteve zakonodaje v državi uporabnika.

PRAVILNO RAZSTAVLJANJE ELEKTROMOTORJEV

Razstavljanje elektromotorjev je osnovna naloga pri recikliranju, enako zahtevna kot samo sestavljanje. Glede na zahtevnost terja izkušeno in izučeno osebo, ki bo delo opravila strokovno in varno.

LOČEVANJE RAZLIČNIH MATERIALOV

OHIŠJE, OHIŠJA LEŽAJEV, ŠČITI IN VENTILATORJI

Vsi ti sestavni deli so narejeni iz konstrukcijskega jekla, ki se mora reciklirati glede na zahteve zakonodaje v državi uporabnika. Vsa dodatna oprema, kabli, priključki kot tudi ležaji, se morajo odstraniti preden se material pretopi.

SESTAVNI DELI, KI VSEBUJEJO ELEKTRIČNO IZOLACIJO

Stator in rotor sta glavna sestavna dela, ki vsebujeta tudi elektro izolacijske materiale. Izdelek pa sestavljajo še druge komponente, ki prav tako vsebujejo podobne materiale, ki jih je potrebno obravnavati po enakih postopkih. To so različni skozniki, ki se uporabljajo v priključni omarici, vzbujevalniki, napetostni in tokovni transformatorji, priključni kabli, razne žice in kondenzatorji.

Nekatere od teh komponent se uporabljajo le v sinhronskih motorjih, druge pa se porabljajo le v zelo specialnih napravah.

Po izteku življenjske dobe izdelka, so njegovi deli neuporabni. Nekateri deli, predvsem stator in rotor, vsebujejo velik delež bakra, ki ga lahko izločimo s pravilnim postopkom toplotne predelave, pri katerih organski materiali, ki so uporabljeni kot izolatorji, zgorijo. Da se zagotovi pravilno zgorevanje hlapov, mora imeti peč za gorenje ustrezno predgrevalno enoto. Da se zagotovi minimalno emisijo med procesom toplotne predelave, je potrebno izpolnjevati naslednje pogoje:

POSTOPEK

Temperatura: 380-420°C (716...788°F)

Čas segrevanja: Ko se obdelovanec segreje na 90% ciljne temperature, ga je potrebno zadrževati na tej temperaturi minimalno pet ur.

POSTOPEK PO IZGOREVANJU BINDER (VKLJUČENIH) HLAPOV

Temperatura: 850-920°C (1562...1688°F)

Čas zgorevanja: Plini, ki jih vsebuje izdelek, se morajo zadržati najmanj tri sekunde v zgorevalni komori.

OPOMBA: Emisija vsebuje v glavnem O₂-, CO-, C NO_x-, -, NO_x-, C_x H_x-, pline in mikro prah. Upravljalca procesa predelave zagotavlja, da je postopek v skladu z zahtevami zakonodaje v državi uporabnika.

OPOMBA: Proces zgorevanja in rokovanje z opremo za izgorevanje zahteva posebno pozornost in znanje, da ne pride do požara ali eksplozije. Ker se pri tem uporabljajo različne naprave in postopki, ni mogoče zahtevati, da Bartec-Varnost izdela navodila za rokovanje in postopke za različne naprave. Zato mora prevzeti odgovornost za ustrezno izvajanje postopka stranka.

NEVARNI ODPADKI

Olje in mast iz sistema za mazanje predstavlja nevarne odpadke in se mora z njimi postopati glede na zahteve zakonodaje v državi uporabnika.

NENEVARNI ODPADKI

S celotnim izolacijskim materialom je potrebno ravnati kot z nenevarnimi odpadki.

BARTEC VARNOST d.o.o.

Cesta 9. Avgusta 59
1410 Zagorje ob Savi, SLOVENIJA

Telefon: +386 59 221 402

Telefax: +386 59 221 400

E-mail: info@Bartec-Varnost.si

Introduction

Bartec Varnost d.o.o. is committed to its environmental policy. Bartec Varnost d.o.o. continuously strives to make its products more environmentally sound by applying results obtained in recyclability and life cycle analyses.

Products, manufacturing processes and even logistics have been designed to take environmental aspects into account. Bartec Varnost d.o.o. environmental management system, certified to ISO 14001, is the tool for carrying out the environmental policy.

The following instructions should only be seen as recommendations for environmentally sound disposal of machines. It is the customer's responsibility to ensure that local regulations are followed. Some customer-specific items may not be included in this User's Manual. Additional documentation will be found in the project documentation.

Average material content

The average material content used in the manufacturing of the electrical machine is as follows:

	Cast iron frame induction machines	Modular steel frame induction machines
Steel	46 %	82 %
Copper	16 %	11 %
Cast iron	31 %	1 %
Plastics, rubber, insulation materials etc.	3 %	3 %
Other	4 %	3 %

Recycling of packaging material

Once the machine has arrived on site, the packaging material will need to be removed.

- Any wood packaging can be burned
- For some countries, the packaging used for shipping by sea is made of impregnated wood that must be recycled according to local regulations
- Plastic material around the machine can be recycled
- Any anti-corrosive agent covering the machine surface can be removed using a petrol based detergent and a cleaning rag. The rag must be disposed of in accordance with local regulations.

Dismantling of the machine

Dismantling the machine is a basic procedure as it is assembled with bolts. However, due to the weight, it requires an operator trained in handling heavy components to prevent dangerous situations.

Separation of different materials**Frame, bearing housing, covers and fan**

These parts are made of structural steel, which can be recycled according to local instructions. All the auxiliary equipment, cabling as well as bearings have to be removed before melting the material.

Components with electrical insulation

The stator and the rotor are the main components, which include electrical insulation materials. There are, however, auxiliary components which are constructed of similar materials and which are hence dealt with in the same manner. This includes various insulators used in the terminal box, exciter, voltage and current transformers, power cables, instrumentation wires, surge arrestors and capacitors. Some of these components are used only in synchronous machines and some are used only in a very limited number of machines.

All these components are in an inert stage once the manufacturing of the machine has been completed. Some components, in particular the stator and the rotor, contain a considerable amount of copper which can be separated in a proper heat treatment process, where the organic binder materials of the electrical insulation are gasified. To ensure a proper burning of then fumes, the oven shall include a suitable after burning unit. The following conditions are recommended for the heat treatment and for the after burning to minimize the emissions from the process:

Heat treatment

Temperature: 380-420°C (716...788°F)

Duration: After obtaining 90% of the target temperature, the object shall stay a minimum of five hours at his temperature.

After burning of the binder fumes

Temperature: 850-920°C (1562-1688°F).

Flow rate: The binder fumes shall stay a minimum of three seconds in the burning chamber

NOTE: The emission consists mainly of O₂-, CO-, CO₂-, NO_x-, C_xH_y-gases and microscopic particles. It is on the user's responsibility to ensure that the process complies with the local legislation.

NOTE: The heat treatment process and the maintenance of the heat treatment equipment require special care in order to avoid any risk for fire hazards or explosions. Due to various installations used for the purpose it is not possible for Bartec Varnost to give detailed instructions of the heat treatment process, or the maintenance of the heat treatment equipment and these aspects must be taken care of by the customer.

Hazardous waste

The oil from the lubrication system is a hazardous waste and has to be handled according to local instructions.,

Land fill waste

All insulation material can be handled as a land fill waste.

BARTEC VARNOST d.o.o.

Cesta 9. Avgusta 59
1410 Zagorje ob Savi, SLOWENIEN

Telefon: +386 59 221 402
Telefax: +386 59 221 400
E-mail: info@Bartec-Varnost.si

EINLEITUNG

Bartec Varnost ist zur Einhaltung der Umweltpolitik verpflichtet. Wir sorgen bei Bartec Varnost ständig dafür, dass unsere Produkte umweltfreundlich sind und berücksichtigen bei der Planung ihre Lebensdauer und die Art der Verwertung nach deren Auslaufen. Produkte, Produktionsprozesse und auch die Logistik wurden umweltfreundlich gestaltet. Bartec Varnost hat ein, nach dem ISO 14001 Standard zertifiziertes Umweltschutzsystem eingerichtet, das ein wirksames Werkzeug für den Umweltschutz darstellt.

Die beiliegenden Anweisungen dienen als Empfehlungen zum umweltfreundlichen Recycling nach Ablauf der Lebensdauer. Pflicht des Käufers ist es, sicherzustellen, dass die Auflagen seiner Gebietskörperschaft beachtet werden. Die Anweisungen erfüllen nicht alle Anforderungen der Kunden, daher muss eine zusätzliche Dokumentation in der Projektdokumentation erworben werden.

IN EINEM STANDARD-ELEKTROMOTOR ENTHALTENE MATERIALIEN

Ein Standard-Elektromotor enthält folgende Materialien:

	Stahlguss- gehäuse	Gehäuse aus geschweißtem Stahlblech
Stahl	46%	82%
Kupfer	16%	11%
Stahlguss	31%	1%
Isoliermaterialien	3%	3%
Sonstiges	4%	3%

RECYCLING VON VERPACKUNGSMATERIALIEN

Das Material, das als Verpackung dient, muss sofort bei Ankunft des Produktes am Einbauort entfernt werden.

- Alle Holzteile können verbrannt werden.
- Für einige Staaten muss eine Schiffs-Transportverpackung aus imprägniertem Holz hergestellt werden, die gemäß lokaler Auflagen zu recyceln ist.
- Materialien aus Plastik können recycelt werden.
- Der Korrosionsschutz, der das Produkt während des Transports schützt, ist mit Fettlösern und Reinigungstüchern zu entfernen. Verunreinigte Tücher sind gemäß den gesetzlichen Auflagen und den Auflagen der lokalen Gebietskörperschaft zu entsorgen.

ORDNUNGSGEMÄSSES ZERLEGEN VON ELEKTROMOTOREN

Das Zerlegen von Elektromotoren ist die Grundaufgabe beim Recycling und ebenso anspruchsvoll wie deren Zusammenbau. Angesichts dieser Anforderungen verlangt es eine erfahrene und ausgebildete Person, die die Arbeit sicher und fachmännisch durchführt.

**TRENNUNG UNTERSCHIEDLICHER MATERIALIEN
GEHÄUSE, LAGERGEHÄUSE, ABSCHIRMUNGEN UND VENTILATOREN**

All diese Teile bestehen aus Konstruktionsstahl, der gemäß den Auflagen der lokalen Gebietskörperschaften entsorgt werden muss. Zusätzliches Zubehör, Kabel, Anschlüsse sowie Lager, müssen entfernt werden bevor das Material eingeschmolzen wird.

BESTANDTEILE, DIE EINE ELEKTROISOLATION ENTHALTEN

Stator und Rotor sind die Hauptbestandteile, die auch Elektroisulationsmaterialien enthalten. Das Produkt ist noch aus weiteren Komponenten zusammengesetzt, die ähnliche Materialien enthalten, die das gleiche Verfahren erfordern. Dies sind verschiedene Durchführungsisolatoren, die in Anschlusskästen verwendet werden, Erreger, Spannungs- und Stromtransformatoren, Anschlusskabel, diverse Drähte und Kondensatoren. Einige dieser Komponenten werden nur in Synchronmotoren verwendet, andere nur in sehr speziellen Geräten.

Nach Ablauf der Lebensdauer des Produkts sind seine Teile unbrauchbar. Einige Teile, vor allem Stator und Rotor, haben einen hohen Kupferanteil, der sich durch ein ordnungsgemäßes Hitzebehandlungsverfahren aussondern lässt, bei dem organische Materialien, die als Isolatoren dienen, verbrennen. Um ein ordnungsgemäßes Verbrennen der Dämpfe sicherzustellen, muss der Verbrennungsofen über eine geeignete Vorwärmeeinheit verfügen. Um eine minimale Emission während des Hitzebehandlungsverfahrens zu gewährleisten, müssen folgende Bedingungen erfüllt sein:

VERFAHREN

Temperatur: 380—420 °C (716—788 °F)

Erhitzungszeit: Wenn sich das Werkstück auf 90% der Zieltemperatur erhitzt hat, muss es mindestens fünf Stunden auf dieser Temperatur gehalten werden.

BINDE-VERFAHREN ZUR VERBRENNUNG DER (ENTHALTENEN) DÄMPFE

Temperatur: 850—920 °C (1562—1688 °F)

Verbrennungszeit: Im Produkt enthaltene Gase müssen mindestens drei Sekunden in der Verbrennungskammer verbleiben.

ANMERKUNG: Die Emissionen enthalten hauptsächlich O₂, CO, C NO_x, -, NO_x, C_x H_x-Gase und Mikrostaub. Der Prozessführer der Verwertung stellt sicher, dass das Verfahren den gemäß den Auflagen der lokalen Gebietskörperschaft und der Gesetzgebung abläuft.

ANMERKUNG: Der Verbrennungsprozess und die Handhabung der Verbrennungseinrichtung erfordern besondere Aufmerksamkeit und Kenntnisse, damit es nicht zu einem Brand oder einer Explosion kommt. Da hierbei verschiedene Geräte und Verfahren zur Anwendung kommen, kann nicht verlangt werden, dass Bartec-Varnost eine Anleitung zur Handhabung und einem Verfahren mit verschiedenen Geräten erarbeitet. Daher liegt die Verantwortung für eine ordnungsgemäße Ausführung des Verfahrens beim Kunden.

GEFAHRABFÄLLE

Öl und Fett aus dem Schmiersystem stellen Gefahrenabfälle dar, mit denen gemäß den Auflagen der lokalen Gebietskörperschaft zu verfahren ist.

DEPONIEABFÄLLE

Mit dem gesamten Isoliermaterial ist wie mit Deponieabfällen zu verfahren.

BARTEC VARNOST , d.o.o.

C.9.avgusta 59
1410 Zagorje ob Savi
SLOVENIJA

Tél.: +++ 386 59 221 402
Fax: +++ 386 59 221 400

E-mail : info@bartec-varnost.si