

Line bushing

Type 07-91..-...../....

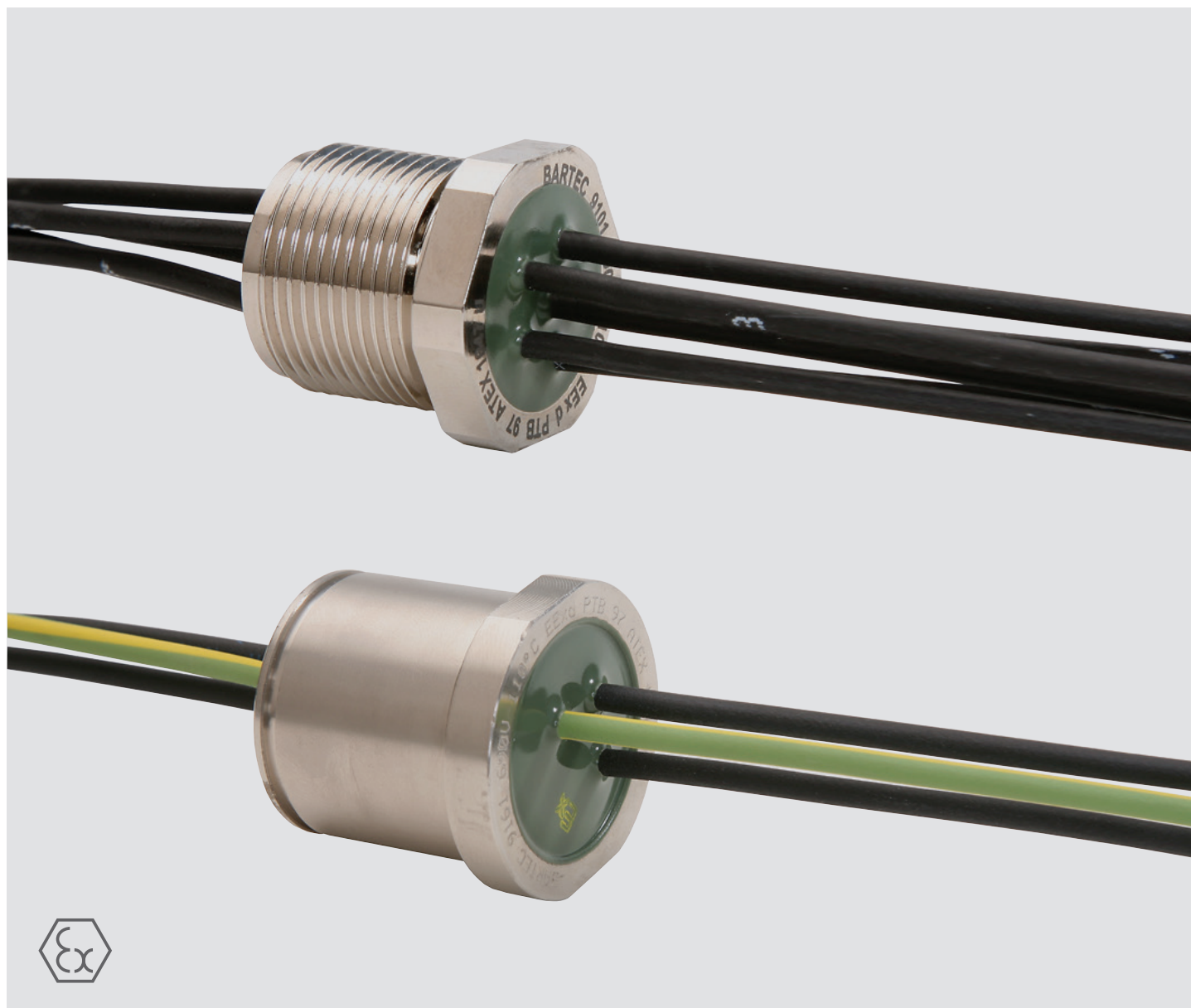

Line bushing

Type 07-91..-...../.....

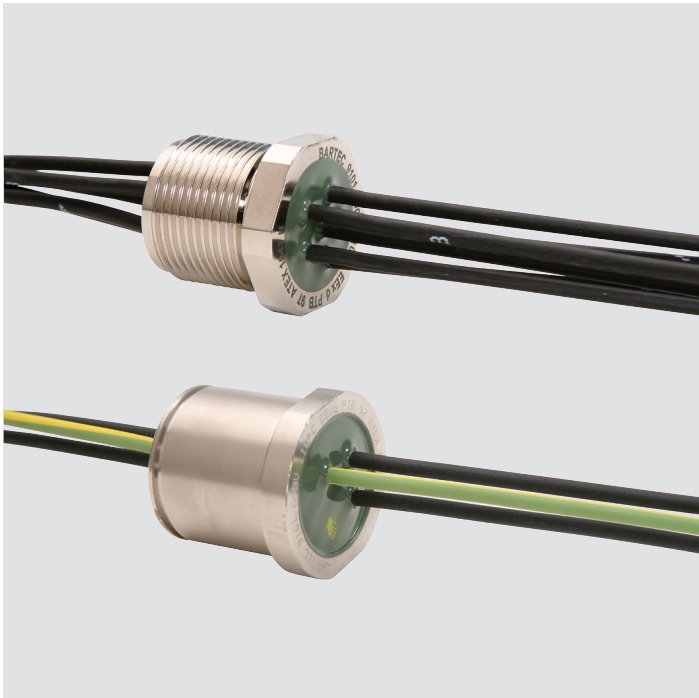

Note on instructions

When working in hazardous areas, the safety of personnel and equipment depends on compliance with the relevant safety regulations. The people in charge of installation and maintenance bear a special responsibility. It is essential that they have an exact knowledge of the applicable rules and regulations.

The instructions provide a summary of the most important safety measures and must be read by everyone working with the product so that they will be familiar with the correct handling of the product.

The instructions have to be kept for future reference and must be available throughout the expected life of the product.

Description

The line bushings, type 07-91..-...../..... are used for the electrical connection of equipment in explosion-proof enclosures or they serve as the connection between an increased safety “e” enclosure and a flameproof “d” enclosure.

The line bushing consists of a metallic threaded or non-threaded sleeve or of a double (threaded / non-threaded) sleeve, encapsulating one or more cores providing a flameproof barrier. The lengths of these cores depend on the respective application. The line bushing with non-threaded sleeve can also be equipped with a mounting flange.

The pressure-proof and vacuum-tight versions, type 07-91..-...../...../U.. and type 07-91..-...../...../D.., prevent a transfer of mass through the conductor and a drop in pressure and vacuum.

Explosion protection

ATEX Ex protection type	⊕ II 2G Ex db IIC Gb ⊕ I M2 Ex db I Mb
IECEX Ex protection type	Ex db IIC Gb Ex db I Mb
CSA Ex protection type	Class I, Zone 1, Ex/AEx db IIC Class I Div 1 Groups A,B,C,D
Certification	EPS 13 ATEX 1619 U CML 21 UKEX 1851U IECEX EPS 13.0045U FM18US0166X (FM J.I. 1Q5A5.AE) CSA 09CA2227587U UL E225236 CCC 2020322313000818 KCS 20-KA4B0-0191U CML 21UKEX 1851 U
Ambient temperature	Depends on the design and the conductors, see marking of the line bushing, packing label as well as accompanying documents.
Operating temperature Line bushing with conductors (Exemplary cables)	
For fixed installation	
4GAF	-55 °C to +110 °C (-67 °F to +230 °F)
FBL	-40 °C to +105 °C (-40 °F to +221 °F)
H05G-K, H07G-K	-55 °C to +110 °C (-67 °F to +230 °F)
H05V-K, H07V-K	-30 °C to +70 °C (-22 °F to +158 °F)
NSGAFÖU	-40 °C to +90 °C (-40 °F to +194 °F)
(N)HXSGAFHXÖ	-40 °C to +110 °C (-40 °F to +230 °F)
RADOX 125	-60 °C to +110 °C (-76 °F to +230 °F)
RADOX 155	-60 °C to +110 °C (-76 °F to +230 °F)
RADOX UL/CSA	-55 °C to +110 °C (-67 °F to +230 °F)
BETAtherm 145 (UL3266)	-60 °C to +125 °C (-76 °F to +257 °F)
BETAtherm 145 (UL3271/UL3820) ..	-60 °C to +125 °C (-76 °F to +257 °F)
BETAtherm 145 UL/CSA	-60 °C to +110 °C (-76 °F to +230 °F)
RG 178 LFH	-30 °C to +105 °C (-22 °F to +221 °F)
RG 179 LFH	-30 °C to +105 °C (-22 °F to +221 °F)
RG 58 C/U	-40 °C to +70 °C (-40 °F to +158 °F)
ENVIROFLEX 178	-40 °C to +105 °C (-40 °F to +221 °F)
ENVIROFLEX 316	-40 °C to +105 °C (-40 °F to +221 °F)
PROFIBUS FC Standard GP	-40 °C to +75 °C (-40 °F to +167 °F)
6XV1830-OEH10	
UNITRONIC BUS L2FIP	-40 °C to +80 °C (-40 °F to +176 °F)
UNITRONIC BUS PB FD FRNC FC	-40 °C to +80 °C (-40 °F to +176 °F)
Pressure	07-91..-...../U..: -500 mbar to 6 bar (-7,25 psi to 87 psi) 07-91..-...../D.. with a supplemental seal: -900 mbar to 80 bar (-13,05 psi to 1160,3 psi) Depends on the respective version, see marking of the line bushing, packing label as well as accompanying documents.
Approved for	Zone 1 and 2 / Division 1 and 2

Electrical data

Nominal voltage	max. 6000 V		
Nominal section	0.08 mm ² to 185 mm ²		
Rated current	0.08 mm ²	1 A	10 mm ² 50 A
	0.2 mm ²	3 A	16 mm ² 67 A
	0.3 mm ²	4,5 A	25 mm ² 90 A
	0.35 mm ²	5,5 A	35 mm ² 110 A
	0.5 mm ²	7,5 A	50 mm ² 140 A
	0.75 mm ²	10 A	70 mm ² 170 A
	1.0 mm ²	12 A	95 mm ² 200 A
	1.5 mm ²	15 A	120 mm ² 240 A
	2.5 mm ²	21 A	150 mm ² 270 A
	4.0 mm ²	28 A	185 mm ² 310 A
6.0 mm ²	36 A		

(These values serve for orientation. The exact value must be determined in the final application).

Depends on the respective version, see marking of the line bushing, packing label as well as accompanying documents.

Mechanical data

Sleeve material	Metal, bare, varnished or electro-plated
Thread size	M10x1 to M72x1.5 (depending on approval)
External diameter of the sleeve	10 mm to 70 mm (Tol. -0.03/-0.1) (0.39 in to 2.76 in)
Gap length of the sleeve	L ≥ 12.5 mm (0.49 in)
	L ≥ 25 mm (0.98 in)
	L ≥ 40 mm (1.57 in)
Dimensions	See separate dimension sheet.

Safety Instructions

The line bushings are suitable for use in zones 1/2.

The line bushing may be used only for the approved purpose.

Unprotected, incorrect installation can cause malfunctioning and the loss of explosion protection.

When determining the maximum current carrying capacity of the connection cores, consideration must be given to their self-heating and the enclosure heating at the place of installation at maximum ambient temperature.

Utilization in areas other than those specified or the modification of the product by anyone other than the manufacturer is not permitted and will exempt BARTEC from liability for defects and any further liability.

The generally applicable statutory rules and other binding directives relating to workplace safety, accident prevention and environmental protection must be observed.

The line bushings may be operated only if they are clean and not damaged in any way. It is not permissible to convert or modify the line bushings.

Marking

Particularly important points in these instructions are marked with a symbol:

DANGER indicates a hazardous situation which, if not avoided, will result in death or serious injury.

WARNING indicates a hazardous situation which, if not avoided, could result in death or serious injury.

CAUTION indicates a hazardous situation which, if not avoided, could result in minor or moderate injury.

NOTICE is used to address practices not related to personal injury.

NOTE Important instructions and information on effective, economical and environmentally compatible handling.

Standards conformed to

See EU Attestation of Conformity (page 7).

Transport, Storage

NOTICE
Damage to the line bushings through incorrect transport or incorrect storage.

- Transport and storage is permissible in original packaging only.

Assembly, Installation, and Commissioning

WARNING
 Risk of serious injury due to incorrect proceedings.

- Only authorized and qualified personnel may do any of the assembly, disassembly, installation and commissioning work.

Assembly/Disassembly

WARNING
 Risk of serious injury due to incorrect assembly.

- When assembling the equipment, the IEC/ EN 60079-14 (NEC for USA/CEC for Canada) and other applicable national standards and installation regulations must be observed.
- Tapped holes, into which line bushings are screwed, must meet the minimum requirements of IEC/EN 60079-1, section 5.3 (table 4 and 5). Observe the minimum depth of engagement. This requires comparing the length of the thread in the line bushing with the minimum depths of engagement in Table 4. A threading length which is longer or equal to the lengths specified in Table 4 must be selected.
- Boreholes into which the line bushings are inserted must meet the minimum requirements of IEC/EN 60079-1, section 5.2 (table 2 or 3). Observe the minimum lengths and gap widths.
- Select the quality of the conductors so that they correspond to the thermal and mechanical requirements of the respective range of application.

Check when assembling:

- Use appropriate tools.

Thread size	Max. tightening torque
M10 x 1	10 Nm (7.376 lb.ft)
M16 x 1	15 Nm (11.06 lb.ft)
M16 x 1.5	15 Nm (11.06 lb.ft)
M20 x 1.5	25 Nm (18.44 lb.ft)
M24 x 1.5	35 Nm (25.81 lb.ft)
M25 x 1.5	35 Nm (25.81 lb.ft)
M33 x 1.5	50 Nm (36.88 lb.ft)
M36 x 1.5	50 Nm (36.88 lb.ft)
M38 x 1.5	50 Nm (36.88 lb.ft)
M42 x 1.5	50 Nm (36.88 lb.ft)
M48 x 1.5	50 Nm (36.88 lb.ft)
M56 x 1.5	50 Nm (36.88 lb.ft)
M64 x 1.5	70 Nm (51.63 lb.ft)
M72 x 1.5	80 Nm (59.01 lb.ft)

- Make sure the line bushing is in perfect condition.
- Fasten the line bushing in the electrical operating equipment in a way that will prevent rotation and self-loosening. Customary aids are: lock washer, locknut, adhesive, retaining ring, etc. Assembly instruction, see page 6.
- The minimum bending radius of the cores used must be complied with during installation. The beginning of the bending radius must be at least 5 mm away from the casting resin outlet. There must be no lateral tensile stress on the cables, as otherwise the cast resin edge can work its way into the insulation. Installation instructions see page 6.

- If a coaxial cable is used, it must be insulated and laid according to its design.
- If sealing materials are used, they must be selected to ensure compliance with the specified operating temperature and chemical resistance.
- Do not use sealing material over Ex gaps.
- No draught may be applied to the core/sheathed cable on the casting resin outlet during installation.

Installation

Check when installing:

- Install the line bushing with terminals carefully, taking into consideration the special conditions in the EU type examination certificate in accordance with IEC/EN 60079-0.
- Cores that are not needed must be wired to terminals.
- All core cables and hose lines must be laid firmly and installed with strain relief.
- The assignment of temperatures to the temperature class of the line bushing should be specified in the type test for the respective electrical equipment.
- Cylindrical drill holes into which line bushings with a cylindrical gap are installed must correspond to the minimum requirements set out under EN 60079-1, Table 2 or 3 (cylindrical gap). Here attention must be paid to the information in the manual regarding the outer diameters of cylindrical tubes. This cylindrical gap must be incorporated into the type test in accordance with EN 60079-1 Section 15.3 in line with the group definition for the respective electrical equipment (group definition I, IIA, IIB or IIC).
- The maximum lever length of a type 07-91*9-***/*S*** connection attachment is 100 mm.
- If the outlet der of the optical fibre is located within the potentially explosive area, the optical performance of the optical fibre must be limited within type of protection „op is“ in accordance with EN 60079-28.

NOTE The pressure-proof and vacuum-tight version must conform to the Pressure Equipment Directive 2014/68/EU and the relevant standards it contains.

Commissioning

Before commissioning, check that:

- The line bushings are assembled and installed correctly.
- The line bushings and its core cable are not damaged.
- The conductors have been laid correctly.
- The junction space is clean.
- The connection has been established properly.

NOTE Temperature ranges are specified for fixed installed cables. For flexible installation it is necessary to contact the manufacturer.

Operation

DANGER
 Death or serious injury due to improper use.

- The line bushings may be operated only within the technical limits that apply to them (see page 2 to 3).

Maintenance and Fault Clearance

WARNING
 Risk of serious injury due to incorrect proceedings.

- Only authorized qualified personnel may do any of the work relating to maintenance and fault clearance.
- IEC/EN 60079-17 must be observed.

Maintenance

WARNING
 Risk of serious accidents due to damaged parts.

- Check line bushings and cables regularly for cracks and damage. Make sure that they are properly established.

The operator of line bushings must keep them in good condition, operate them properly, monitor them and clean them regularly.

Fault Clearance

WARNING
 Risk of serious injury due to use of non-original spare parts.

- Use original parts only as replacements.

Defective line bushings cannot be repaired; they must be replaced considering this operational instruction.

Accessories, Spare Parts

See www.bartec.com

Assembly Instruction

NOTE The line bushings in the sketches are used as examples for all different types of line bushings.

Disposal

The components in the line bushings contain metal and plastic parts. Therefore the statutory requirements for disposing of electronic scrap must be observed (e.g. disposal by an approved disposal company).



Service Address

BARTEC GmbH
 Max-Eyth-Str. 16
 97980 Bad Mergentheim
 Germany

Phone: +49 7931 597 0
info@bartec.com
bartec.com

For Line Bushings with Threads

- Protection against twisting and self-loosening by securing with a locknut.

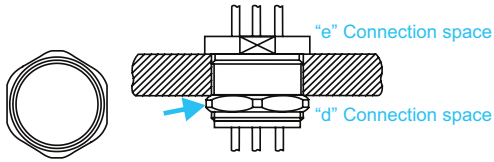

- Protection against twisting and self-loosening by means of a lock washer.

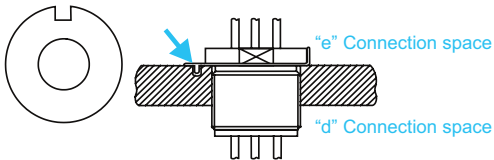

- Protection against twisting and self-loosening by gluing in place with a temperature-resistant adhesive.

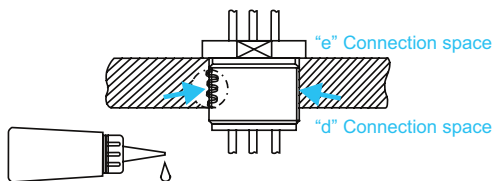

Bending radius of the line

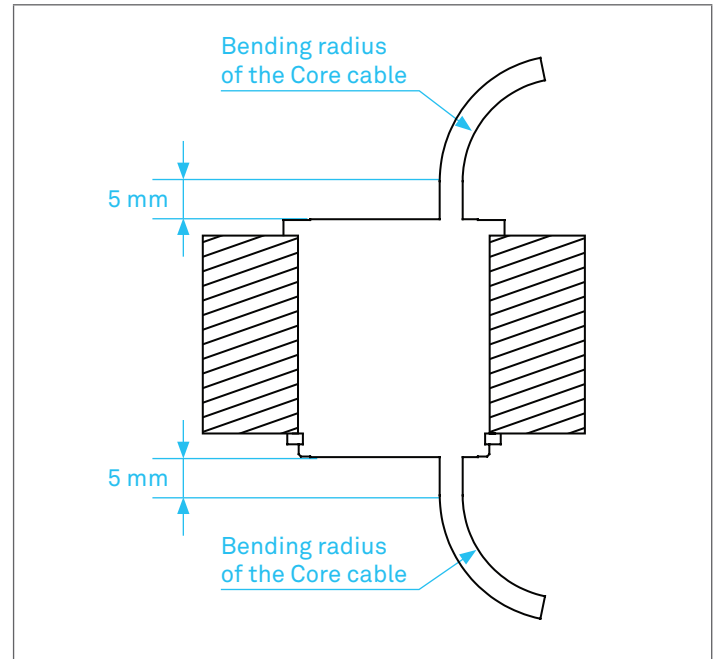

For pluggable Line Bushings

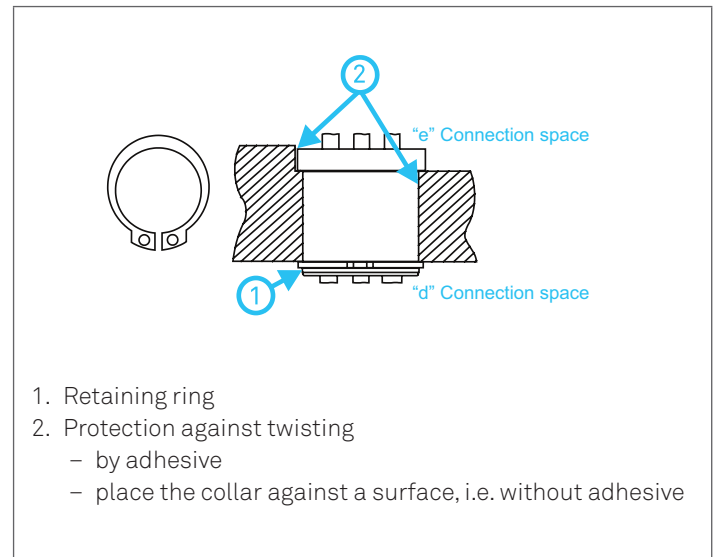

1. Retaining ring
2. Protection against twisting
 - by adhesive
 - place the collar against a surface, i.e. without adhesive

Disclaimer: We reserve the right to make technical changes. Changes, errors and printing errors do not justify claims for damages.

Nº 01-9100-7C0001-G

Wir	We	Nous
BARTEC GmbH Max-Eyth-Straße 16 97980 Bad Mergentheim Germany		
erklären in alleiniger Verantwortung, dass das Produkt Leitungsdurchführung	declare under our sole responsibility that the product Line bushing	attestons sous notre seule responsabilité que le produit Traversée de cloison

Typ 07-91-****/****, 57-91**-****/******

auf das sich diese Erklärung bezieht den Anforderungen der folgen- den Richtlinien (RL) entspricht ATEX-Richtlinie 2014/34/EU RoHS-Richtlinie 2011/65/EU und mit folgenden Normen oder nor- mativen Dokumenten übereinstimmt	to which this declaration relates is in accordance with the provision of the following directives (D) ATEX-Directive 2014/34/EU RoHS-Directive 2011/65/EU and is in conformity with the following standards or other normative documents	se référant à cette attestation correspond aux dispositions des directives (D) suivantes Directive ATEX 2014/34/UE Directive RoHS 2011/65/UE et est conforme aux normes ou docu- ments normatifs ci-dessous
--	--	---

EN IEC 60079-0:2018
EN 60079-1:2014

EN IEC 63000:2018

Verfahren der EU-Baumuster- prüfung / Benannte Stelle	Procedure of EU-Type Examination / Notified Body	Procédure d'examen UE de type / Organisme Notifié
--	---	--

EPS 13 ATEX 1619 U(*) – Issue 3

2004, Bureau Veritas Germany GmbH, 86842 Türkheim

(*) Die Ex-Komponente ist Teil eines elektrischen Betriebsmittels oder eines Moduls, gekennzeichnet mit dem Symbol „U“, das nicht für sich allein verwendet werden darf und über dessen Einbau in elektrische Betriebsmittel oder Systeme zur Verwendung in explosionsgefährdeten Bereichen gesondert entschieden werden muss. Merkmale dieser Komponente sowie die Bedingungen für ihren Einbau in Geräte und Schutzsysteme siehe Betriebsanleitung der Komponente.	(*) The Ex-component is a part of an electrical apparatus or a module, marked with the symbol “U”, which is not intended to be used alone and requires additional consideration when incorporated into electrical apparatus or systems for use in explosive atmospheres. Characteristics and how the component must be incorporated into equipment or protective systems see operation manual of the component.	(*) Le composant Ex est partie de matériel électrique ou de module, marquée du symbol « U », ne devant pas être utilisée seule et nécessitant une certification complémentaire lorsqu'elle est incorporée à un matériel électrique ou à un système pour atmosphères explosives. Les caractéristiques du composant ainsi que les conditions d'incorporation dans des appareils ou des systèmes de protection regarde voir l'instruction d'emploi du composant.
---	--	--

0044

Bad Mergentheim, 24.01.2024

i.A. Simon Dyhringer
 Product Manager Ex e

i.A. Steffen Mika
 Team leader Certification
 Management R&D ESS

BARTEC

BARTEC GmbH
Max-Eyth-Str. 16
97980 Bad Mergentheim
Germany

Tel.: +49 7931 597-0
Fax: +49 7931 597-119

bartec.com