

PAPDB

Barrier cable glands for armoured, lead sheathed cables



Installation

hazardous areas - Zone 1 / 2 (Gases) - Zone 21 / 22 (Dusts)

Classification

Group II - Category 2G 2D / 3G 3D

Mechanical characteristics

Body / cap	Standard production: OT-58 brass UNI EN12164/5 (ON) AISI-316L stainless steel (XX) Marine grade copper free aluminium (AL) (on project request only) On request production: CW711R naval brass EN 12164/8 CW712R naval brass EN 12163/7 CW719R naval brass EN 12163/7 CW724R brass EN 12163/7 CW510L brass EN 12163/7
Finishes	full nickel plating treatment (brass material only)
Rubber rings	EPDM rubber 50-60 shore hardness (standard supply) SILICON rubber 60 shore hardness (on demand only)
O-ring	silicon rubber - 60 shore hardness
Skid washer	nylon 6.0
Chamber for sealing	OT-58 brass OT-58 nickel plated brass (on demand) AISI-316L stainless steel (on demand)

Reference standards

Directive 2014/34/EU	
Execution	<ul style="list-style-type: none"> Ⓜ II 2 G Ex db / Ex eb/ Ex ia/ IIC Gb Ⓜ II 2 D Ex tb IIIC Db Ⓜ II 3 G Ex nR IIC Gc Ⓜ II 3 D Ex tc IIIC Dc
Rules of compliance	EN/IEC 60079-0; EN/IEC 60079-1; EN/IEC 60079-7; EN/IEC 60079-11; EN/IEC 60079-15; EN/IEC 60079-31
EU Type-Examination Certificate	INERIS 09 ATEX 0028X INERIS 23 ATEX 3004X (Ex nR only)
Protection degree	IP66 or IP66/68
Ambient temperature	-40 °C ÷ +90 °C (Rubber rings EPDM-60) -60 °C ÷ +100 °C (Rubber rings SILICON)
Other Available Certificates	IECEx: IECEx INE 11.0017X ECASEx: 23-06-22481/Q23-06-048569/NB0002 INMETRO: CEPEL 12.2177X KC: in progress

Applications

For steel wire armoured cables (swa) for steel tape armoured cables and for lead inner sheath cables

Double Compression Type For Indoor And Outdoor Use

Provided armour clamping using clamping arrangements suitable for all armour wire/braid types

Double compression - under armour and overall of armour cable (inner and outer sealing)

Internal lead device for electrical bond of cable lead inner sheath. Sealing with proper resin into "chamber of sealing"

On Request Accessories

- Locknuts, Gaskets, PVC Shrouds, Earthing Tags, Sealing, (See DL-NW-PTD-ET bulletin)

Cable gland selection table

Code (1)	Size	Entry thread size						Dia. under armour		Outer sheath dia.		Hexagon [mm]	Material	
		Metric	(2)	NPT	(2)	ISO 228	(2)	min [mm]	max [mm]	min [mm]	max [mm]		(3)	
PAPDB#	01	ISO-M20	M	1/2" NPT	N	1/2"	G	3.5 6.0 8.5	6.0 8.5 11.0	10.0 14.0	15.0 19.0	32.0	Nickel pl. brass Stainless steel	ON XX
PAPDB#	02	ISO-M25	M	3/4" NPT	N	3/4"	G	8.5 11.0 13.5	11.0 13.5 16.0	15.0 19.0	20.0 24.0	36.0	Nickel pl. brass Stainless steel	ON XX
PAPDB#	03	ISO-M32	M	1" NPT	N	1"	G	13.0 16.0 19.0	16.0 19.0 22.0	20.0 25.0	26.0 31.0	45.0	Nickel pl. brass Stainless steel	ON XX
PAPDB#	04	ISO-M40	M	1 1/4" NPT	N	1 1/4"	G	19.0 22.0 25.0	22.0 25.0 28.0	26.0 31.0 34.0	32.0 37.0 40.0	53.0	Nickel pl. brass Stainless steel	ON XX
PAPDB#	05	ISO-M50	M	1 1/2" NPT	N	1 1/2"	G	22.0 25.0 28.0 31.0	25.0 28.0 31.0 34.0	30.0 36.0 40.0	37.0 43.0 47.0	61.0	Nickel pl. brass Stainless steel	ON XX
PAPDB#	06	ISO-M63	M	2" NPT	N	2"	G	34.0 37.0 40.0	37.0 40.0 43.0	42.0 47.0 50.0	48.0 53.0 56.0	71.0	Nickel pl. brass Stainless steel	ON XX
PAPDB#	07	ISO-M75	M	2 1/2" NPT	N	2 1/2"	G	40.0 43.0 46.0 49.0	43.0 46.0 49.0 52.0	52.0 58.0 61.0	58.0 64.0 67.0	84.0	Nickel pl. brass Stainless steel	ON XX
PAPDB#	08	ISO-M90	M	3" NPT	N	3"	G	52.0 56.0 57.0 60.0 63.0	55.0 59.0 60.0 63.0 66.0	65.0 71.0 74.0	72.0 78.0 81.0	101.0	Nickel pl. brass Stainless steel	ON XX
PAPDB#	09	ISO-M115	M	4" NPT	N	4"	G	58.0 66.0 72.0 78.0 84.0	66.0 72.0 78.0 84.0 90.0	81.0 88.0 96.0	88.0 96.0 104.0	126.0	Nickel pl. brass Stainless steel	ON XX

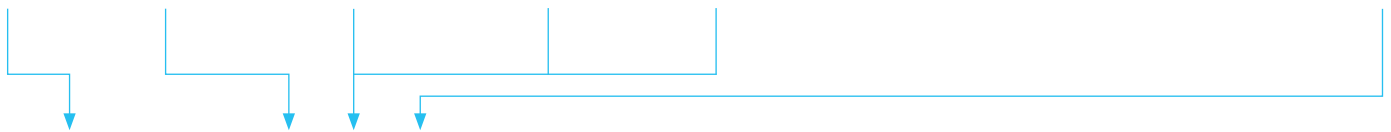

P	A	P	D	B	#	0	1	M	O	N	→ PAPDB#01MON (barrier cable gland nickel plated brass ISO-M20 THR.)
P	A	P	D	B	#	0	3	N	X	X	→ PAPDB#03NXX (barrier cable gland stainless steel 1" NPT THR.)

Cable gland ordering examples

Legend

(1) –	cable gland type/model	PAPDB# = barrier cable gland
(2) –	threading	M = ISO metric pitch 1,5mm / N =NPT (ANSI/ASME B1.20.1) / G = ISO-228
(3) –	cable gland material	ON – nickel plated brass / XX = AISI-316l stainless steel

PAPDB dimensional

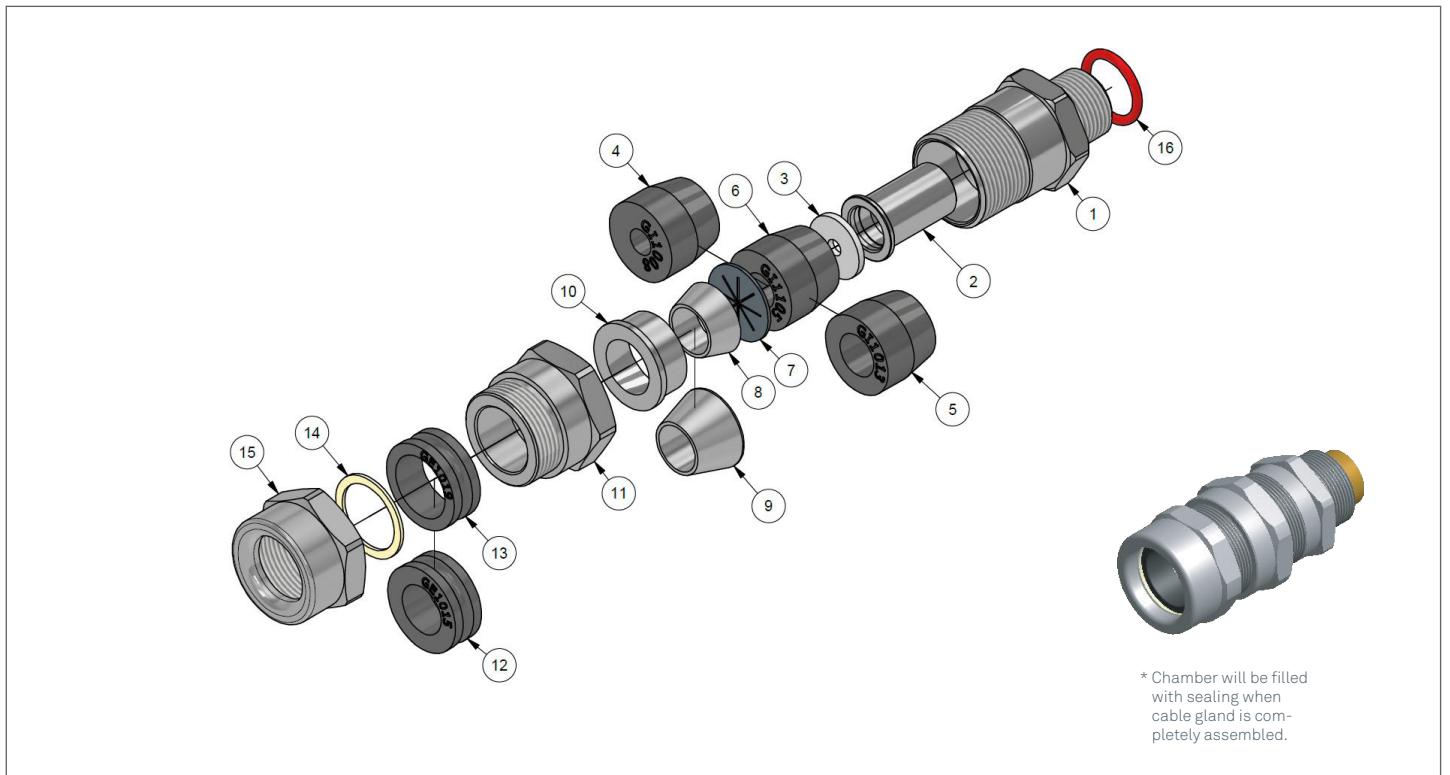

1	Barrier cable gland body
2	Sealing chamber
3	Resin seal rubber
4 - 5 - 6	Inner rubber seal
7	Lead sheath earth ring
8 - 9	Pushing seal cone
10	Armour clamping ring
11	Intermediate gland body
12 - 13	Outer rubber seal
14	Nylon washer
15	Gland nut
16	Or gasket (metric thread only)

Flowable epoxy resin RSN#C0200 (in cans of 200 g)	
Cable gland size	Resin quantity [g]
0	4
1	7
2	12
3	21
4	36
5	53
6	86
7	159
8	250
9	533

Epoxy resin paste kit INN#BR0525		
Code	Cable gland size	Resin quantity [kit]
INN-BR0525-1	0	1
INN-BR0525-1	1	1
INN-BR0525-2	2	1
INN-BR0525-3	3	1
INN-BR0525-5	4	1
INN-BR0525-5	5	1
INN-BR0525-6	6	1
INN-BR0525-7	7	1
INN-BR0525-8	8	1
INN-BR0525-8	9	2

REMARK:
Due to the development of the national and international specifications and of the technology, the above technical characteristics showed on this bulletin can be considered as binding on our confirmation only.