

Hygrophil HP, type 1100-10 / -20

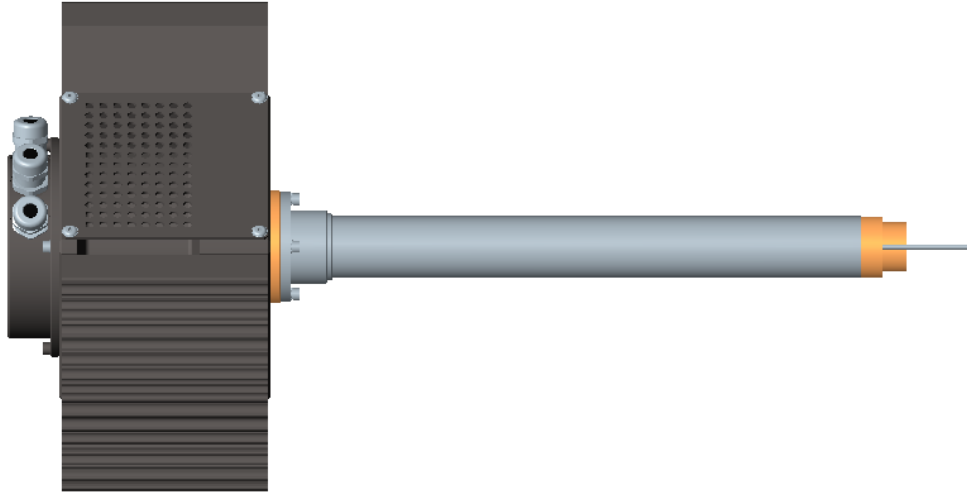

Description

- Process temperature up to 250 °C
- Long-term stability, accurate
- Continuous humidity sensing in industrial processes
- Dew-point measuring range (+6 °C) 20 °C ... 100 °C depending on process temperature
- In situ measurement
- Primary measurement method
- Humidity calculations
 - Dew point DT in °C
 - Relative humidity RH %
 - Moisture volume in %
 - Mixture ratio MH in g/kg
- 2 isolated analogue outputs
- 2 switching outputs (fault, alarm contact)
- DC 24 V
- Easily accessible for servicing

Principle of measurement

The basic principle is a direct measurement of the temperature of dew point. A Peltier cooler is used to cool the sensor tip down to the point at which moisture condenses on the measuring surface. This condensation is detected, and the resulting temperature is output as the dew point after a system-specific conversion. The system of heat sink heat pipes and Peltier cooler allows measurements up to the maximum process temperature of 250 °C.

Technical data	
Humidity measurement	
Principle of measurement	Primary method/dew point
Transducer	Pt1000
Accuracy (dew point)	± 1,5°C
Dew point measuring range (dependent on gas temperature)	(+6°C) 20°C - 100°C
Process temperature measurement	
Transducer	Pt1000
Accuracy	± 2°C
Measuring range	0°C to +300°C
Times (without filter)	
Settling time T90 (cold start)	<3 minutes (process temperature 135°C, dew point 60°C)
Response time T10 (DT 22,5°C -> 80°C)	4 seconds (DT 28,3°C)
Settling time T90 (DT 22,5°C -> 80°C)	58 seconds (DT 74,3°C)
Response time T10 (DT 80°C -> 22,5°C)	10 seconds (DT 74,3°C)
Settling time T90 (DT 80°C -> 22,5°C)	96 seconds (DT 28,3°C)
Electrical data	
Supply power	DC 24 V ± 20%, max. 1,2A @ 24V
Current output	
Analogue output	2 (isolated), active
Output signal	0/4 ... 20 mA
Accuracy	± 0.15%
Load resistance	<600 ohm
Temperature drift	<0.001 mA/°C
Switching output	
Number	2 (isolated)
Design	Transistor output, DC max. 30V / 800mA
Display Modul (optional type 1100-20)	
Display	2,4" OLED-Display yellow, resolution: 128x64 pixel
Operation	4 foil keys with tactile feedback
Status	2 LED`s
Ambient conditions	
Max. process gas temperature	250°C
Operating temperature (electronics)	0 °C ... +50 °C
Storage temperature	-20 °C ... +70 °C
Protection	IP65
Rated conditions	23°C ± 2°C / 24 V ± 0.2 V

Mechanical data

Dimensions type 1100-10

Dimensions 551 mm x 249 mm x 172 mm (basic version), all dimensions in mm

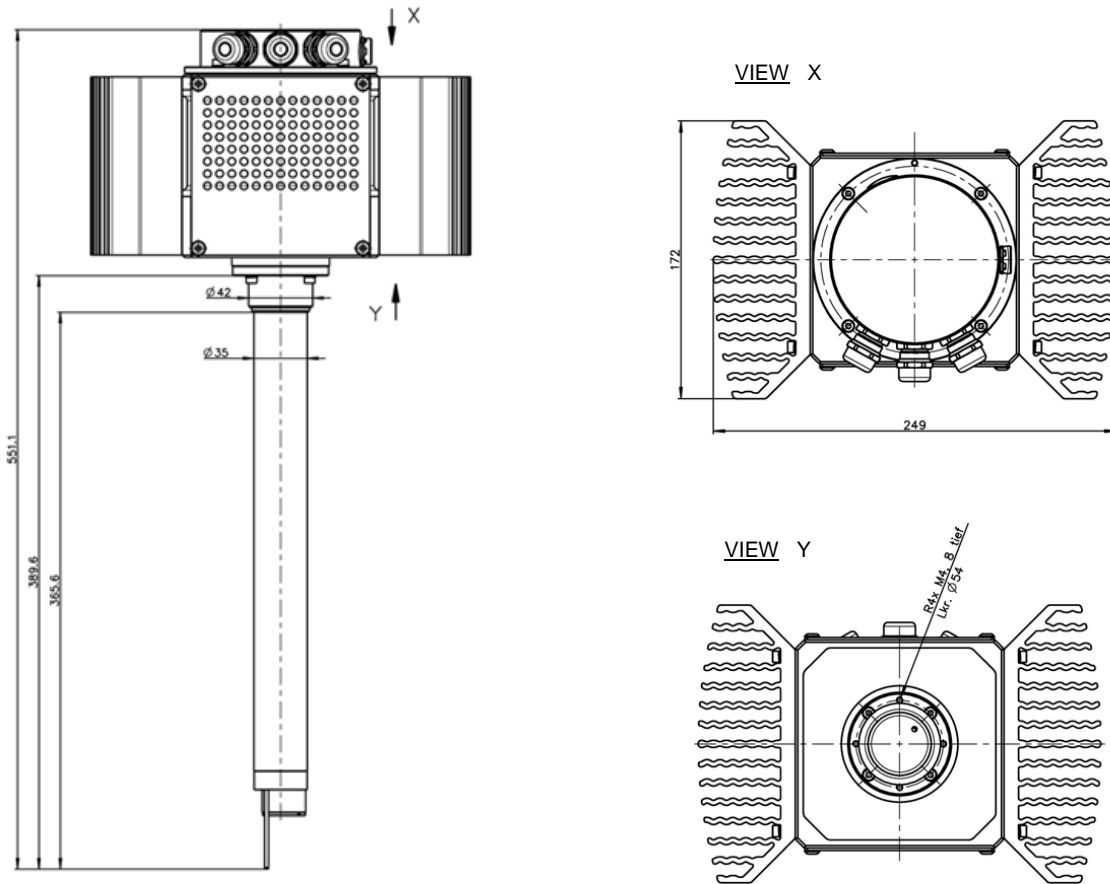

Weight	6 kg
Housing specification (electronics)	Aluminium (black anodised), IP 65
Connections	Screw terminals max. 2,5 mm ² for supply, analogue outputs and switching outputs accessible via 3 x cable entries. Cable diameter 5-10 mm Configuration tool connection - 2.5 mm jack
Sensor tip materials in process zone	Stainless steel 1.4301, ceramic, PEEK, PTFE

Dimensions type 1100-20 (with display)

Dimensions: 565 mm x 249 mm x 172 mm (basic variant), all dimensions in mm

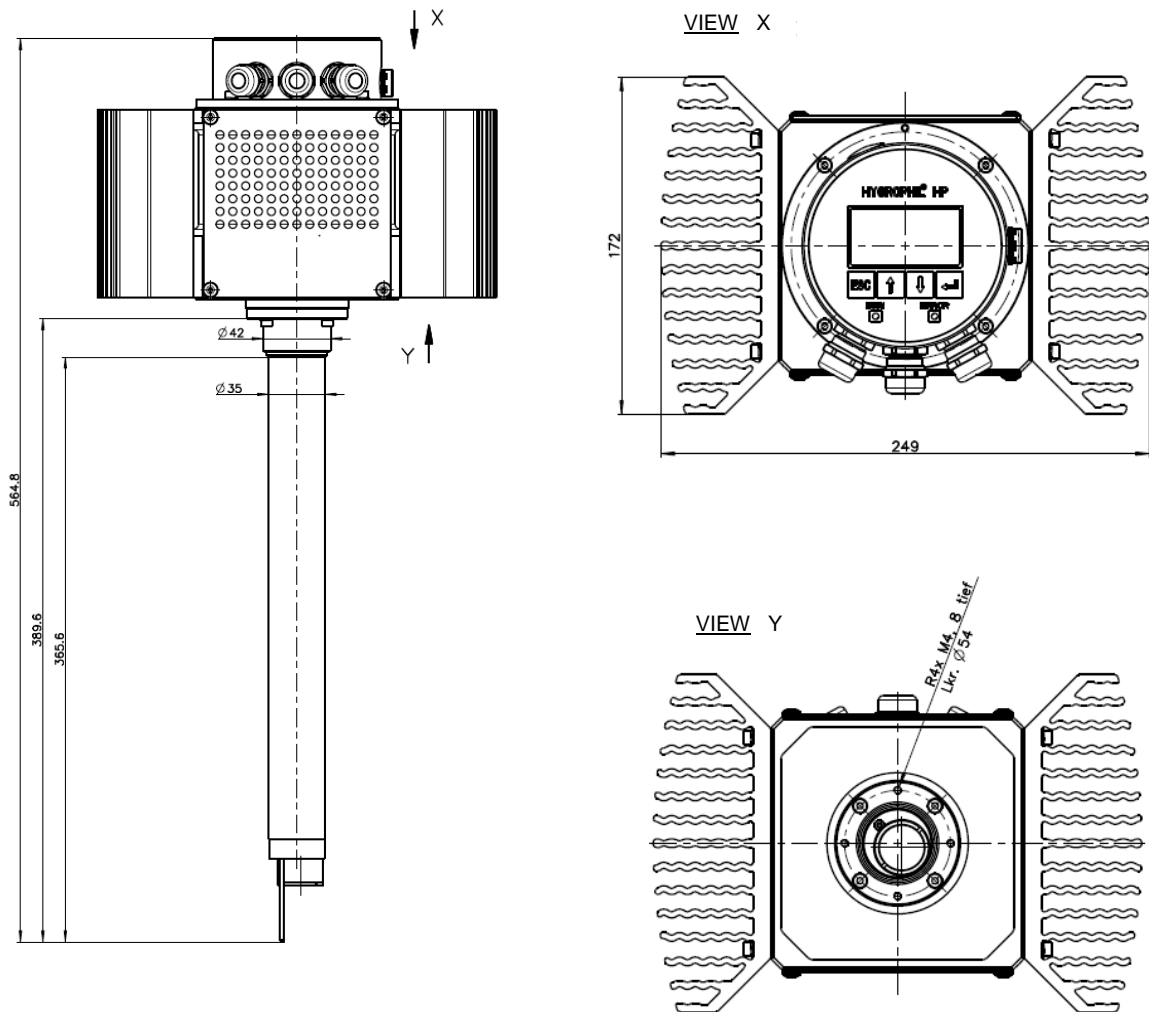

Weight	6 kg
Housing specification (electronics)	Aluminium (black anodised), IP 65
Connections	Screw terminals max. 2,5 mm ² for supply, analogue outputs and switching outputs accessible via 3 x cable entries. Cable diameter 5-10 mm Configuration tool connection - 2.5 mm jack
Sensor tip materials in process zone	Stainless steel 1.4301, ceramic, PEEK, PTFE

Terminal assignment

V_IN:	Power supply
A_OUT1:	Analog output 1
A_OUT2:	Analog output 2
S_OUT1:	Switch output 1
S_OUT2:	Switch output 2
S:	Shield connection

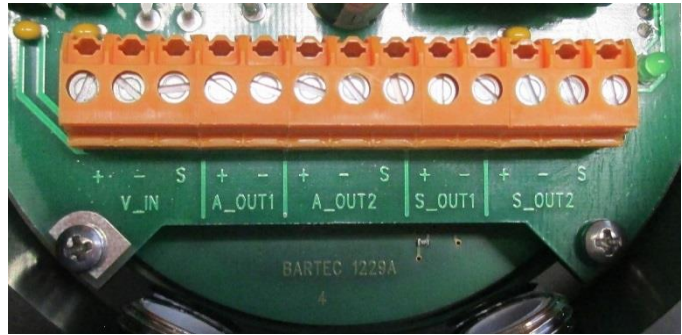

Measuring range

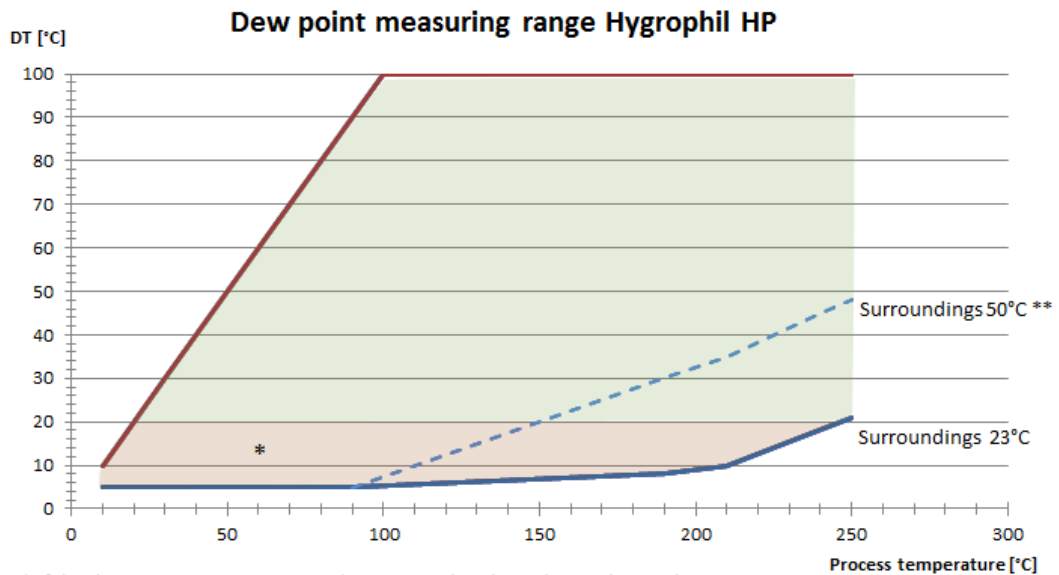

* If the dew point temperature in the process chamber is lower than in the environment, this leads to internal condensation in the sensor. Continued operation under such conditions can damage the sensor.

** Higher ambient temperatures on the heat sink lead to higher minimum measurable dew point temperatures.

Atachements

Filter HP cpl.

Type 1100-300

- Pore size: 100 μ m

Order number: 345627

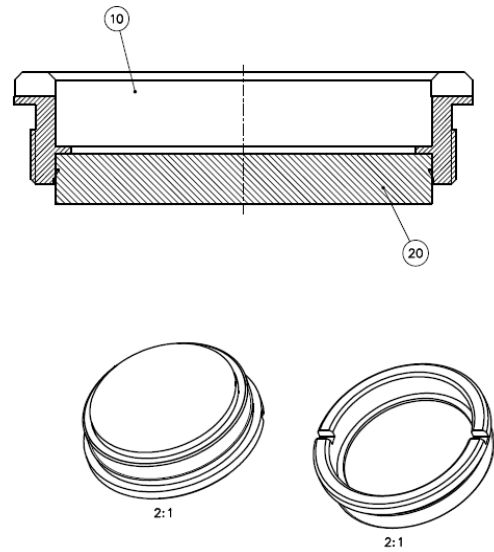

Installation flanges

Type 1700-110

- Material: AlMgSi0,5

Order number: 245408

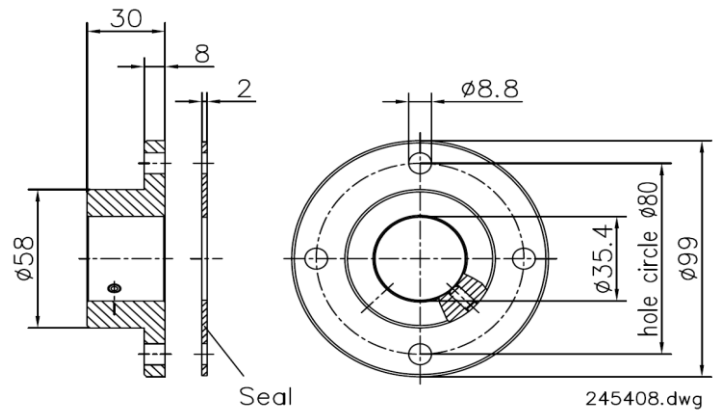

USB configurations adapter

Type 1100-115

- Length ca. 5m

Order number: 349640



